



evoqua
WATER TECHNOLOGIES



WALLACE & TIERNAN[®] CHLORINE MEMBRANE
ELECTROLYSIS SYSTEM
OSEC-NXT 6

INSTRUCTION MANUAL



Note

Original manual!

Contents

1.	Introduction	7
1.1	Documentation	7
1.1	Conventions	8
2.	Safety	11
2.1	Intended use	11
2.2	General safety instructions	12
2.3	Handling chemicals	14
2.4	Liability for defects	19
2.5	Replacement of electrolysis cells	20
3.	Description	21
3.1	Process	21
3.2	System configuration	24
3.3	Versions	26
3.4	Control unit	27
3.5	Functions	29
3.6	Technical data	31
4.	Installation	33
4.1	Scope of supply	33
4.2	Transport and storage	34
4.3	Ambient conditions	36
4.4	Mechanical installation	39
4.5	Electrical installation	43
4.6	Completing the acceptance certificate	46
4.7	Start-up	47
4.8	Connecting to Profibus DP	60

4.9	RS485 bus interface	75
5.	Operation	93
5.1	Control and display unit	93
5.2	Password protection	95
5.3	Automatic mode	97
5.4	Turning on automatic mode	99
5.5	Turning off automatic mode	99
5.6	Activating preparation manually	101
5.7	Stopping preparation manually	102
5.8	Operating messages	103
5.9	Warning messages	111
5.10	Error messages	118
5.11	Reading the cell voltage and electrolysis current	120
5.12	Menus	121
5.13	Maintenance by the operator	147
5.14	Faults	156
6.	Maintenance by a service technician	165
6.1	Performing maintenance	165
6.2	Maintenance parts sets	167
6.3	Detailed maintenance work	172
6.4	Replacing the electrolysis cell	187
6.5	Shut-down	190
6.6	Starting the system up again	192
7.	Dimension drawing	193
8.	Arrangement of components	195
9.	Wiring diagram	199

10. Operating Journal	233
11. Certificate of Conformity	235
12. Index	237



1. Introduction

1.1 Documentation

1.1.1 Target groups

This instruction manual provides the responsible personnel with information that is required for the installation, operation and maintenance of the chlorine membrane electrolysis system.

It contains information that is important to the secure, fault-free, and economical operation of the chlorine membrane electrolysis system. Carefully observing these instructions will help to prevent danger, reduce repair costs and downtimes, and increases the reliability and service life of the chlorine membrane electrolysis system.









The chapters Installation and Maintenance by service technicians are intended exclusively for Evoqua service personnel or for personnel who have been trained and authorized by Evoqua. These chapters contain important information on the assembly, configuration, commissioning, maintenance and repair of the chlorine membrane electrolysis system, which can only be performed by this target groups.



Anyone working with the chlorine membrane electrolysis system must have read and understood the instruction manual, and, in particular, the safety instructions.

Please consult the table of contents and the index to find the information you require quickly.

1.1 Conventions

Notes This instruction manual contains a number of notes with different priorities, which are marked with symbols.

Pictogram	Note	Meaning
	<i>Danger!</i>	Immediate danger to life and limb! If the situation is not handled properly, death or serious injury is the result.
	<i>Warning!</i>	Danger to life and limb! If the situation is not handled properly, death or serious injury may be the result.
	<i>Caution!</i>	If this warning is not observed, medium or slight injury or damage to the equipment may be the result.
	<i>Warning!</i>	Electrical hazard.
	<i>Warning!</i>	Risk of explosion! Smoking, fire, naked light, welding, and work causing sparks are forbidden.
	<i>Caution!</i>	Risk of injury! Leaks can release dangerous fluids or gases, which can cause chemical burns and unconsciousness. Use respiratory protection!
	<i>Caution!</i>	Risk of injury! Leaks can release dangerous fluids or gases. Use face mask!
	<i>Caution!</i>	Risk of injury! Leaks can release dangerous fluids or gases. Wear protective gloves!
	<i>Caution!</i>	Risk of injury! Leaks can release dangerous fluids or gases. Wear apron!

Pictogram	Note	Meaning
	<i>Caution!</i>	Risk of injury! Leaks can release dangerous fluids or gases. Use protective footwear!
	<i>Note</i>	These notes assist in the operation of the system.

Main screen
 MENU
 Menu selection
 System
 Clean display

SYSTEM

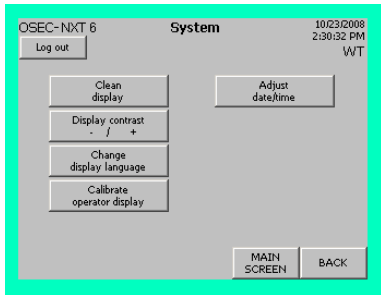

Screenshots of the various controller screens are shown, with the name immediately above the screenshot. The preceding screens are listed in the margin to show the user how to access the current screen.

2. Safety

2.1 Intended use

The chlorine membrane electrolysis system is intended exclusively for the production of sodium hypochlorite solution used to disinfect water.

The operational safety of the system can only be guaranteed if it is used in accordance with its intended purpose. It may only be used for the purpose defined in the contract and under the installation, operating and environmental conditions stated in this instruction manual. No substances (chemicals) may be used other than those described in this instruction manual. All inspection and maintenance work must be carried out at the prescribed intervals.

Compliance with the intended use also includes reading this instruction manual and observing all the instructions it contains.

The operator bears full and sole responsibility if this unit is put to any use which does not comply strictly and exclusively with this intended use.

2.2 General safety instructions

Evoqua attaches great importance to the safety of all work relating to the chlorine membrane electrolysis system. This was already taken into account in the design of the system, by the integration of safety features.

Safety instructions The safety instructions in this documentation must always be observed. These do not affect the validity of any additional national or company safety instructions.

Safety instructions printed on the system All safety instructions attached to the chlorine membrane electrolysis system must be observed. They must always be complete and easily legible.

Technical standard The chlorine membrane electrolysis system has been constructed using the best available technology and according to the accepted safety regulations. However, danger to the life and limbs of users or third parties or damage to the chlorine membrane electrolysis system or other property cannot be ruled out if the system is used by personnel who have not received suitable training and instruction. Installation and maintenance, as well as any work that is not described in this instruction manual may only be performed by trained and authorized personnel.

Personnel The operator of the overall system must ensure that only authorized and qualified technicians can work on or with the chlorine membrane electrolysis system, and within their specified area of responsibility.

"Authorized and qualified personnel" include:

Operation

- System operators, who have been trained and instructed by the operator, by Evoqua or by the service partner

Installation, Start up

- Evoqua service personnel or personnel who have been trained and authorized by Evoqua for installation and start-up work. Installation and start-up may only be performed by such personnel

Maintenance

- Maintenance level 1:
Performed by trained and instructed operators
- Maintenance level 2:
Evoqua service personnel or personnel who have been trained and authorized by Evoqua for maintenance work. Level 2 maintenance may only be performed by such personnel

Electrical work

- Authorized and qualified electrical technicians. All electrical work on the chlorine membrane electrolysis system may only be performed by qualified electricians

<i>Spare parts/components</i>	The trouble-free operation of the chlorine membrane electrolysis system can only be guaranteed, if original spare parts and components are used in the combination described in this instruction manual. Otherwise there is a danger of malfunction or damage to the chlorine membrane electrolysis system.
<i>Modifications and extensions</i>	Never attempt to rebuild, modify or extend the chlorine membrane electrolysis system without written approval from the manufacturer!
<i>Electrical power</i>	During normal operation, the control cabinet must remain closed. Connect cables in accordance with the terminal diagram in chapter 9.
<i>Waste disposal</i>	Ensure safe and environmentally-friendly disposal of agents and replaced parts.

2.3 Handling chemicals

2.3.1 General



Warning!

Chemical hazard!

A substantial quantity of chemicals is produced in the chlorine membrane electrolysis system. For safe operation and to prevent harm to persons, be sure to follow the safety instructions and warnings on the system and in this instruction manual.

Everyone involved must be informed about the dangers arising from fluids and gases in the chlorine membrane electrolysis system and the connected pipes, and be instructed regarding the first aid measures to be employed. For further details see the EC safety data sheets regarding the specified CAS numbers.

The installation site and the areas where dangerous chemicals are stored or decanted must be clearly identified and labeled in accordance with the regulation (e.g. GUV).



The door outside the installation room and the vent opening of the hydrogen vent pipe must carry signs prohibiting fire, naked light and smoking. (The accessories set includes two signs.)

During maintenance and repair work, the following protective clothing must be worn and a gas mask must be available close by.



- Face mask



- Protective gloves.



- Apron



- Protective footwear



- Gas mask

The following chemicals are produced in the chlorine membrane electrolysis system:

- | | |
|------------------------------|-----------------------|
| <i>Product</i> | • Sodium hypochlorite |
| <i>Side product</i> | • Hydrogen |
| <i>Intermediate products</i> | • Sodium hydroxide |
| | • Chlorine gas |
| | • Anolyte |

The intermediate products are produced as part of the process and as such remain temporarily in the system.



Warning!

Chemical hazard!

Leaks can release chemicals that can cause chemical burns. Wear protective clothing. Follow the safety instructions and warnings on the system or on the product and in this operating manual. Consult and follow the EC safety data sheets.

The occurrence and properties of the individual substances are given below. Details on the individual substance can be found in the EC safety data sheet relating to the specified CAS number.

2.3.2 Sodium hypochlorite solution (NaClO)

- | | |
|-------------------------------|--|
| <i>Product identification</i> | • CAS No.: 7681-52-9 |
| <i>Properties</i> | • concentration approx. 23 g/l (- 10 %) chlorine |
| | • develops toxic gases on contact with acid |
| | • irritates eyes and skin |
| <i>Occurrence</i> | • in the reaction zone of the reactor |
| | • in the connection between reactor and sodium hypochlorite tank |
| | • in the sodium hypochlorite storage tank |



Warning!

Chemical hazard!

When sodium hypochlorite meets acids or acid-reacting substances, chlorine gas is released. Chlorine gas is toxic when inhaled and may cause loss of consciousness. Use gas mask!

2.3.3 Hydrogen (H₂)

- Product identification*
- CAS No.: 1333-74-0
- Properties*
- highly flammable
 - gaseous
 - colorless and odorless
- Occurrence*
- in the cathode chamber of the electrolysis cell
 - in the connection pipe between the electrolysis cell and the reactor
 - in the degassing zone of the reactor
 - in the hydrogen vent pipe



Warning!

Risk of explosion!

Hydrogen combines with air to create an explosive mixture and is highly flammable. In the vicinity of the system, smoking, fire, naked light, welding, and work causing sparks are forbidden.

2.3.4 Sodium hydroxide (Sodium hydroxide solution)

- Product identification*
- CAS No.: 1310-73-2
- Properties*
- concentration approx. 4 %
 - caustic
 - colorless and odorless
 - temperature in the process about 40° C - 60° C
- Occurrence*
- in the cathode chamber of the electrolysis cell
 - in the connection pipe between the electrolysis cell and the reactor



Attention!

Chemical hazard!

Sodium hydroxide is caustic and hot in the system (approx. 60° C).
Wear protective clothing!

2.3.5 Chlorine gas (Cl₂)

Product identification

- CAS No.: 7782-50-5

Properties

- chlorine gas saturated with steam
- toxic when inhaled
- irritates the eyes, respiratory organs and skin
- hazardous to the environment
- highly-toxic to aquatic organisms
- green-yellow; pungent odor
- temperature in the process about 40° C - 50° C

Occurrence

- in the anode chamber of the electrolysis cell
- in the connection pipe between the electrolysis cell and the chlorine gas separator
- in the connection pipe between the chlorine gas separator and the reactor
- in the reactor



Attention!

Chemical hazard!

Chlorine gas is toxic when inhaled and may cause loss of consciousness. Use gas mask!

2.3.6 Anolyte

Properties

- reduced brine with approx. 4 to 8 g/l dissolved chlorine
- string chlorine smell
- temperature in the process about 40° C - 50° C

Occurrence

- in the anode chamber of the electrolysis cell
- in the connection pipe between the electrolysis cell and the chlorine gas separator
- in the connection pipe between the chlorine gas separator and the electrolysis cell



Attention!

Chemical hazard!

Chlorine gas is toxic when inhaled and may cause loss of consciousness. Use gas mask!

2.3.7 Prevention of risks

The following applies to all substances:

- avoid all contact. Wear protective clothing
- do not open any screw fittings while the system is preparing the product
- only work on the pipes when the system has been emptied and rinsed
- smoking and naked light are prohibited near the system

Especially for sodium hypochlorite:

- do not bring sodium hypochlorite in contact with acids or acid-reacting substances.

2.3.8 First aid measures

The following applies to all substances:

- remove contaminated clothes immediately
- after skin contact, rinse thoroughly with lots of water
- after eye contact, immediately hold squinting eyes under flowing water or wash out with lots of water, call a doctor straight away
- after swallowing, immediately drink plenty of water, call a doctor straight away
- after inhalation, provide fresh air immediately
- if loss of consciousness is a possibility, the person must lie down or be carried in a stable recovery position
- when any accident or illness occurs immediately call a doctor

2.3.9 Environmental protection measures

Avoid release of chemicals into the environment. Consult the relevant directives regarding this matter. Follow the instructions in the EC safety data sheets and substance data sheets.



Please note

If necessary, you can order a copy of the EU Safety Data Sheet for sodium hypochlorite solution from Evoqua Water Technologies GmbH.

2.4 Liability for defects

Liability for defects is regulated by general terms and conditions of supply (recommended by the "German Electrical and Electronics Manufacturers Association" (ZVEI)) and by special contractual agreements.

The defect liability excludes temporary parts, as per DIN 31051, and wearable parts which have to be replaced at the annual service:

Temporary parts

- Solenoid valves
- Fan (thinning air)
- Cooling fans in the rectifier
- Brine pump
- Rectifier
- Electrolysis cell

Wear parts

- Filter inserts for brine, electrolysis water, operating water
- Level switch of the chlorine separator
- Hydrogen vent hose



Please note

To preserve the liability for defects, the operating and environmental conditions and the operating and maintenance regulations described in this instruction manual must be observed (see below for further details). If they are not observed the liability for defects claim is rendered invalid.

Liability for defects conditions

- Installation, start-up, shut-down, level 2 maintenance and training of operating personnel by Evoqua service personnel or by personnel that have been trained and authorized by Evoqua
- Return the signed original of the start-up checklist to Evoqua Günzburg
- Intended use
- Adhere to operating parameters and default values
- The chlorine membrane electrolysis system may only be controlled by the operator, by Evoqua or, if necessary, by personnel who have been trained and instructed by the service partner
- Keep an operating journal
- Use only the salt prescribed by the manufacturer (e. g. Evoqua OSEC® Salin)
- Do not turn off the chlorine membrane electrolysis system at the main switch or disconnect it from the external power supply for longer than four hours

- If the system must be shutdown for longer than four weeks or disconnected from the mains for longer than four hours, the chlorine membrane electrolysis system must be shut-down
- Do not drain fluid in the electrolysis cells. The membranes must not dry out
- Do not expose chlorine membrane electrolysis system to frost
- Maintenance level 1 is carried out by the operator
- Conclude a maintenance contract
- Maintenance level 2 performed by Evoqua service personnel or by personnel trained and authorized by Evoqua for maintenance work

2.5 Replacement of electrolysis cells

PRO-RATA

The electrolysis cells are subject to technical wear and are therefore temporary parts as per DIN 31051. If the operating and maintenance regulations are observed, the expected operating life of the electrolysis cells is four years (48 months).

For the electrolysis cells, Evoqua offers an exchange on a PRO-RATA basis.

3. Description

3.1 Process

3.1.1 Description of the process

(See also chapter 3.1.2 Process diagram)

The chlorine membrane electrolysis system uses saturated brine, softened water and a direct current to produce sodium hypochlorite solution directly at the site of installation.

The electrolysis cell is the core of the chlorine membrane electrolysis system. The electrolysis cell consists of an anode chamber and a cathode chamber, which are separated from each other by an ion exchange membrane.

The water softener produces completely softened water from drinking water. In the salt dissolving tank, a saturated brine solution is produced from salt and softened water. A dosing pump supplies the brine via the chlorine separator to the anode chamber. Softened water is fed to the cathode chamber.

During operation, a DC voltage is applied to the electrolysis cell, causing the electrochemical reactions to start. Sodium hydroxide and hydrogen gas are produced in the cathode chamber. The brine is reduced and chlorine gas is produced in the anode chamber. This mixture in the anode chamber is called anolyte.

At the upper end of the anode chamber, the anolyte is fed into the chlorine separator, where the chlorine gas is separated from the anolyte. The chlorine gas is fed directly to the reactor, while the anolyte is returned to the anode chamber in a closed circuit, entering at the bottom of the electrolysis cell. Saturated brine is fed automatically into the anode chamber depending on the level in the chamber.

The sodium hydroxide-hydrogen mixture produced in the cathode chamber is fed to the reactor's degassing chamber, where the hydrogen is released from the sodium hydroxide. A fan dilutes the separated hydrogen with air and safely blows it out through the hydrogen vent pipe.

The sodium hydroxide from which the hydrogen has been separated then flows into the reactor's reaction chamber, where the chlorine gas and the sodium hydroxide react, forming sodium hypochlorite. From the reactor, the sodium hypochlorite solution flows into the storage tank, from which it is extracted using a dosing pump and added to the water being treated. Sodium hypochlorite preparation stops once the storage tank is full. Once the "Storage tank min." level is reached, sodium hypochlorite preparation starts again.

3.1.2 Process Diagram

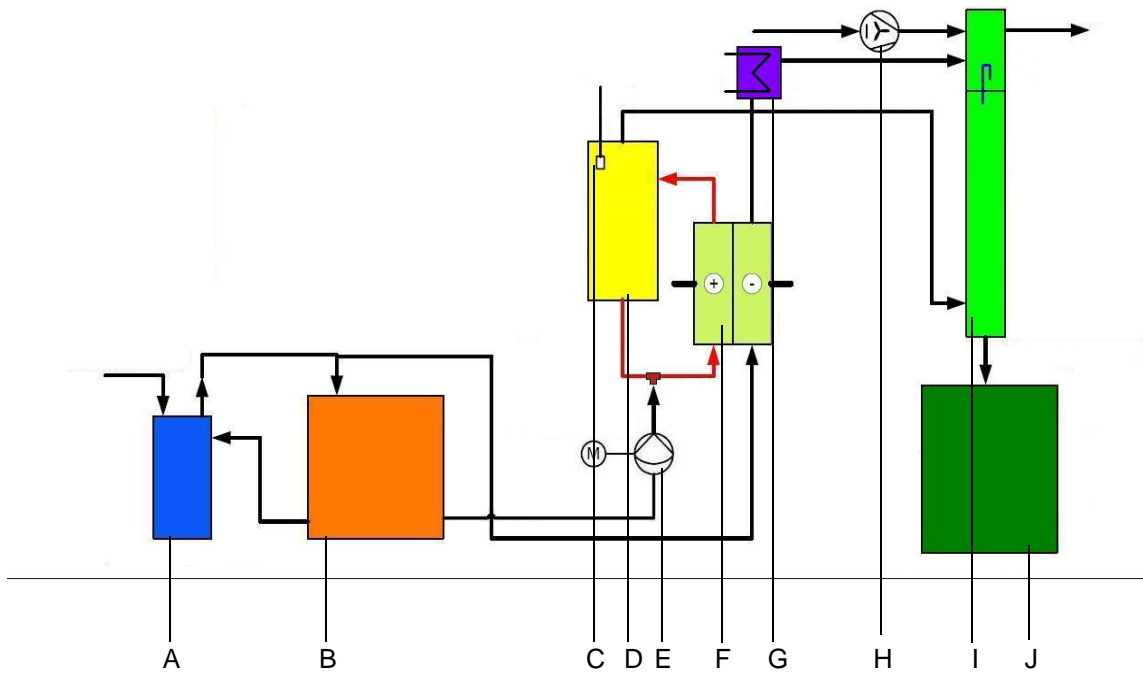

Fig. 1 Chlorine membrane electrolysis system OSEC-NXT 6

- A Water softener
- B Salt dissolving tank
- C Level probe
- D Chlorine separator
- E Brine pump
- F Electrolysis cell
- G Heat exchanger
- H Fan
- I Reactor
- J Sodium hypochlorite storage tank

3.2 System configuration

The chlorine membrane electrolysis system is designed as a compact unit, built around an electrolysis cell, with the following main system components mounted on a frame.



- Electrolysis cell
- Water softener
- Brine pump
- Chlorine separator
- Reactor
- Control cabinet with control and display unit and rectifier
- Salt dissolving tank
- Sodium hypochlorite storage tank
- Heat exchanger

The electrolysis cell is protected from unauthorized access by a cell cover, as shown in detail in chapter 8. Arrangement of components.

Fig. 2 Chlorine membrane electrolysis system OSEC-NXT 6

3.2.1 Electrolysis cell

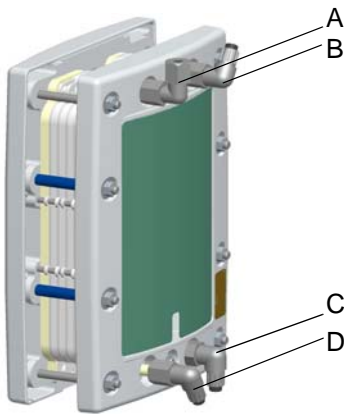

The electrolysis cell consists of an anode chamber and a cathode chamber, which are separated from each other by an ion exchange membrane. The cell housing has four connections:

- A Sodium hydroxide / hydrogen outlet (grey)*
- B Anolyte / chlorine gas outlet (white)*
- C Softened water inlet (grey)*
- D Anolyte inlet (white)*

Fig. 3 Electrolysis cell

3.2.2 Water softener

To produce sodium hypochlorite solution completely softened water must be used. The usage of water not being softened results in irreparable damage to the chlorine membrane electrolysis system and the electrolysis cells. The water softener produces completely softened water from drinking water. Automatic regeneration is usage-based and depends on the hardness of the water.

3.2.3 Brine pump

Regulated by level, the brine pump supplies concentrated brine to the chlorine separator. The brine pump is mounted directly on the salt dissolving tank. No settings are necessary at the brine pump.

3.2.4 Chlorine separator

In the chlorine separator, the chlorine gas generated in the anode chamber is separated from the anolyte and the anolyte is returned to the anode chamber, entering at the bottom of the electrolysis cell.

A level probe in the chlorine separator controls the brine pump.

3.2.5 Reactor

The reactor is divided into two main parts:

- Upper-reactor or degassing chamber, where the hydrogen is released from the sodium hydroxide
- Lower-reactor or reaction chamber, where the chlorine gas reacts with the sodium hydroxide to form sodium hypochlorite

3.2.6 Sodium hypochlorite storage tank

The sodium hypochlorite solution produced is stored in the sodium hypochlorite tank. In automatic mode, sodium hypochlorite preparation is controlled via the level switch in the sodium hypochlorite storage tank. The sodium hypochlorite storage tank has a capacity of 100 l.

3.2.7 Salt dissolving tank

Brine that has been saturated using salt prescribed by the manufacturer (e. g. Evoqua OSEC[®] Salin salt pellets) is deposited and stored in the brine tanks. The salt dissolving tank has a capacity of 60 l.

3.2.8 Heat exchanger

The heat exchanger cools the sodium hydroxide solution after emerging from the cell and before entering the reactor and thus lowers the product temperature. The heat exchanger consists of a titanium pipe, a covered hose (spiral hose), and the connections for the inlet and outlet of the cooling water.

3.2.9 Control cabinet with control and display unit

<i>Housing</i>	The control system (details in chapter 3.4 Control unit) of the chlorine membrane electrolysis system and the rectifier are housed in a steel housing mounted on the left hand narrow side of the mounting frame. The main switch and the control and display unit are arranged on the front side of the control cabinet.
<i>Rectifier</i>	The rectifier converts the alternating current of the mains power into the direct current required for operating the electrolysis cell.
<i>Main switch</i>	The main switch turns the power off for the entire chlorine membrane electrolysis system. The power supply to the gas monitoring system is not switched off.



Danger!

Risk of injury or death!

The system may still be live, even if the main switch is off!



Attention!

Damage to the system!

Only turn off at the main switch in case of emergency as doing so will deactivate critical safety functions! If the system is switched off and disconnected from the power supply for a prolonged period (> 4 hours) the electrolysis cell may be permanently damaged.

<i>Control and display unit</i>	The control and display unit is used to configure and display the system settings and to display operating messages, warning messages and error messages.
---------------------------------	---

3.3 Versions

The chlorine membrane electrolysis system is available in one size.

Part No.	Nominal performance rating	Number of electrolysis cells
W3T162715	6 kg/d chlorine	1

3.4 Control unit

The control unit is used to log, display and process measurement data as well as to control the process.

A touch panel is used as the control and display unit. The system is controlled using the buttons. All of the settings and operating parameters can be read by all users, in any user group, without requiring the user to enter a password. Some of the functions are password protected and are only accessible to certain users. See chapter 3.5 for details.

Measurements

Measurements that can be recorded and processed:

- Cell voltage
- Protective voltage
- Electrolysis current
- Operating water pressure
- Flow rates
- Ambient temperature
- Switching state of the connected sensor system (e.g. leak sensor)
- Mains overvoltage
- Mains undervoltage
- Phase sequence
- Phase failure/neutral conductor failure

Displays

- Operating states and operating messages
- Warning messages and error messages
- Settings and operating parameters

Functions

Functions integrated in the control system:

- Water softener system control
- Salt dissolving tank replenishment controller
- Electrolysis water controller
- Cooling water controller
- Evaluation and processing of the level switch signal
- Brine pump controller
- Electrolysis current controller
- Metering lock for dosing pumps (optional)

Safety functions

- Monitoring of salt dissolving tank replenishment
- Monitoring of replenishment of the chlorine separator
- Monitoring of water softening regeneration
- Monitoring of hydrogen dilution
- Monitoring of electrolysis current and cell voltage
- Monitoring of cooling water and electrolysis water
- Monitoring of operating water pressure
- Monitoring of ambient temperature
- Monitoring of rectifier
- Monitoring of power supply
- Control of automatic stopcock in the event of leaks, overfilling or chlorine gas alarm
- Control of alarm light/alarm horn
- Digital input EMERGENCY STOP
- Password protection

Interfaces

The control system provides interfaces to the bus systems Wallace & Tiernan RS485 bus and Profibus DP.

- Evoqua RS485 bus interface
The serial RS485 Bus interface is used for data transfer to the optional Process Monitoring System. In addition to this, it is also possible to connect other Evoqua devices with an RS485 bus interface
- Profibus DP interface
The Profibus DP interface is a standardized interface (EN50170) for data transmission. Using the Profibus DP interface the chlorine membrane electrolysis system can be connected to an existing Profibus DP network

Process Monitoring System

The Process Monitoring System, which is installed as an option, is used to log and display the measurements taken, for remote diagnosis, and to provide remote access via a standard browser with Internet and e-mail capability. Using the RS485 bus interface it is also possible to connect other Evoqua devices to the Process Monitoring System.

There is a separate operating manual for Process Monitoring System, which can be ordered from Evoqua Water Technologies GmbH if required.

Part No.	Language
W3T166939	German
W3T159186	English
W3T159187	French

3.5 Functions

All of the settings and operating parameters can be read by all users, in any user group, without requiring the user to log in. Certain functions are protected, requiring entry of a user name and password, so that they can only be performed by certain groups.

There are three user levels:

- Level 1: No password required. For operators and service personnel
- Level 2: Password required. For operators and service personnel
- Level 3: Password required. Only for service personnel

Level 1 No password or user name is required. All of the functions of this level may be used by the operators.

The functions include:

- Displaying all of the settings and operating parameters as well as the operating messages, warning messages and error messages
- Clean display
- Decreasing/increasing the display contrast
- Change display language

Level 2 Password and user name required. All of the functions of this level may be used by the operators. The user name is WT and the password is 9040.

The functions include:

- All functions of level 1
- Selecting the mode (automatic or manual)
- Starting and stopping preparation manually
- Resetting the system

Outputs

- Configuring the alarm relay assignment
- Configuring the alarm relay switching function (NO or NC)
- Configuring the alarm relay switching function delay

Diagnostics

- Resetting the operating hours (Day uptime counter)
- Checking the total soft water hardness

- | | |
|-------------------------|---|
| <i>Service</i> | <ul style="list-style-type: none"> • Setting the max. filling time for the salt dissolving tank • Setting the slowdown time for the salt dissolving tank • Carrying out monthly maintenance • Starting manual overfilling of the chlorine separator • Configuring the anolyte compensation interval • Configuring the total operating water hardness • Calibrating the electrolysis water flow meter |
| <i>System</i> | <ul style="list-style-type: none"> • Calibrating the display • Adjust date/time |
| <i>Manual functions</i> | <ul style="list-style-type: none"> • Switching the electrolysis water on and off • Switching the cooling water on and off • Switching brine filling on and off • Regenerating the water softener • Testing the water softener inlet • Testing the water softener flushing • Testing the water softener injector |



Please note

The operator functions are described in full detail in chapter 5. Operation.

Level 3

A user name and password are required. All of the functions on this level are to be found in the main "Service" menu and may only be used by Evoqua service personnel or by personnel who have been trained and authorized by Evoqua. This password is only available to those users.

The functions include:

- | | |
|----------------|--|
| <i>Service</i> | <ul style="list-style-type: none"> • All functions of level 1 and 2 • Parameter reset • Carrying out annual maintenance • Configuring the values |
|----------------|--|



Please note

Details on entering the passwords are found in chapter Operation, 5.2.2 Logging in.

3.6 Technical data

3.6.1 OSEC-NXT 6

Nominal performance rating	6 kg/d chlorine
Number of cell blocks	1
Electrolysis water	12 l/h
Cooling water	60 l/h
Max. cell voltage	10 V, DC
Max. electrolysis current	150 A
Power consumption in operating state „Stand-by“, approx.	50 W
Mains connection	1/N/PE AC 230 V, 50/60 Hz
Max. permissible voltage tolerance V_{eff} .	+ 10 % / - 10 %
Power supply capacity	2,4 kVA
cos phi, approx.	0,95
Max. permissible pre-fuse	1 x 20 A
Dimensions (WxHxD)	1200 x 1895 x 750 mm
Weight, filled, approx.	448 kg
Protection type	IP 13

3.6.2 PROFIBUS DP

Hardware	SIMATIC S7-300 controller CPU314C - 2DP V3.x
Transmission technology	RS-485 in accordance with the Profibus specifications
Baud rate	Max. 12 Mbit/s, autodetect
Bus address	Default setting 20, Adjustable from 3 - 125
Bus connection	9 pin D-Sub socket
Communication	Cyclic I/O data exchange between the DP master and the DP slave(s).
Configuration	6 x 16 words, data consistency over the entire length 1 x 13 words, data consistency over the entire length 1 x 4 words, data consistency over the entire length

4. Installation

4.1 Scope of supply

The scope of supply includes:

- Chlorine membrane electrolysis system compact design, mounted on a frame
- Accessory set, comprising:
 - Drum pump
 - Water hardness test kit
 - Air flow monitor
 - Elbow connector hydrogen vent pipe
 - 4 hinged feet
 - Hoses
 - Funnel
 - Information signs
- 30 l of 4% sodium hydroxide
- 10 l of 9% hydrochloric acid
- Instruction manual

4.2 Transport and storage

Transport/Storage

The chlorine membrane electrolysis system is correctly packaged by Evoqua and delivered on a palette that is suitable for vertical transport.

The electrolysis cell is filled with softened water.

During transport, the chlorine membrane electrolysis system must be handled with care.



Attention!

Risk of injury and damage to the system!

Follow the instructions and warnings on the packaging relating to transport.

Please note the following:

- The system must be secured against tilting
- The system must not be exposed to frost, damp weather or wet
- The system must be lifted using an appropriate lifting device, e.g. fork-lift truck
- When transporting by crane, the lifting lugs provided on the system must be used

Unpacking



Attention!

Risk of injury and damage to the system!

Follow the instructions and warnings on the packaging.

Check that the transport packaging is undamaged. In the event of damage, please inform the transport company immediately, as your rights to compensation will otherwise be lost. Keep the packaging until the chlorine membrane electrolysis system has been put successfully into operation.

If the system is damaged, please contact Wallace & Tiernan immediately.

Check the shipment for completeness based on the delivery note. Any missing items must be reported to the transport company and the supplier immediately.

Internal transport The chlorine membrane electrolysis system is equipped with four transport rollers specifically for internal transport. At the installation site they must be exchanged for the hinged feet provided in the accessories set.

Shut-down The chlorine membrane electrolysis system may only be taken out of operation by trained and authorized personnel or by Evoqua service personnel. A shut-down is necessitated by the following:

- a standstill period of the sodium hypochlorite preparation for more than four weeks
- a disconnection from the power supply longer than four hours (e.g. announced power failure)

For further details see chapter Maintenance, 6.5 Shut-down.



Attention!

Damage to the electrolysis cell!

If the system is switched off and disconnected from the power supply for a prolonged period (> 4 hours) the electrolysis cell may be permanently damaged.

4.3 Ambient conditions



Please note

Trouble-free operation of the chlorine membrane electrolysis system is only guaranteed if the environmental requirements are met. Observe the applicable local and national regulations!

4.3.1 Installation room

The following requirements apply to the installation room of the chlorine membrane electrolysis system:

General

- The place of installation must not be accessible to the public
- The place of installation must not be used as anybody's permanent workplace
- The door to the room must carry a sign prohibiting fire, naked light and smoking (included in the accessories set)
- In the vicinity of the system, smoking, fire, naked light, welding work, and work causing sparks are forbidden
- Make sure there is a supply of fresh air (min. 285 m³/h)
- The system must be installed on a flat and stable surface in accordance with the tolerance specifications for finished floors for demanding applications contained in DIN 18202. A gentle slope due to floor drainage is acceptable, as long as the part of the floor where the system is located is within the specified limits
- Provide floor drainage
- The system must be accessible and visible from all sides. It must be possible to fully open the control cabinet door. See dimension drawing chapter 7.
- Hydrogen vent pipes must be installed in a continuous upward gradient

Temperature and humidity

- During operation of the system, the temperature in the installation room must be between min. 10° C and max. 30° C



Please note

Note the heat emission from the system!

- Temperature drops of greater than 15°C (e.g. caused by fresh air inlets) are not permitted in the immediate vicinity of the system
- Humidity from 5 % to 95 %, non-condensing

4.3.2 Operating water

The following requirements apply to the operating water:

- | | |
|---------------------------|---|
| <i>Water quality</i> | <ul style="list-style-type: none"> • only drinking water as per WHO Guidelines for Drinking Water Quality, third edition |
| <i>Water temperature</i> | <ul style="list-style-type: none"> • minimum 8°C • maximum 20°C |
| <i>Admission pressure</i> | <ul style="list-style-type: none"> • at least 3.7 bar for a max. supply rate of 200 l/h • maximum 10 bar |
| <i>Connection</i> | <ul style="list-style-type: none"> • according to DIN EN 1717 |



Attention!

Damage to the system!

The minimum admission pressure of 3.7 bar (for a max. supply rate of 200 l/h) must always be adhered to, even if water is taken by other on-site users. Otherwise the correct functioning of the system can be disturbed!

4.3.3 Interface brine

The following requirements apply to the brine:

- | | |
|--------------------------|--|
| <i>Brine quality</i> | <ul style="list-style-type: none"> • salt approved by the manufacturer of the chlorine membrane electrolysis system (e. g. Evoqua special salt OSEC® Salin) |
| <i>Brine temperature</i> | <ul style="list-style-type: none"> • corresponding to room temperature of the chlorine membrane electrolysis system or lower |

4.3.4 Interface hydrogen vent pipe

The following requirements apply to the hydrogen vent pipe:

- | | |
|---------------------|--|
| <i>Material</i> | <ul style="list-style-type: none"> • gas-tight plastic vent pipe (PVC, PE or PP) DN 100 |
| <i>Installation</i> | <ul style="list-style-type: none"> • a separate air vent is required for each chlorine membrane electrolysis system • installed in a continuous upward gradient, gas tight, secure against damage • max. 60 m long, with max. 20 bends (no corner pieces) • the use of flue dampers or shut-off devices is not permitted • position opening above roof level or at least 3 m above ground level |

- the opening must not be accessible to the public or in the direct vicinity of access areas. Minimum distance from doors, windows or other openings: 3 m. Minimum distance from other air vents: 10 m
- keep the openings clear and protect against ingress of debris or rainwater by means of a hood or a bend
- the opening must be accessible for start-up and yearly maintenance
- labels with warning notices



Warning!

Risk of explosion!

Leaks may release hydrogen. Hydrogen combines with air to create an explosive mixture and is highly flammable. To ensure safe, trouble-free operation, it is imperative to follow the assembly instructions given in this chapter.

4.3.5 Interface cooling water drain

Pressure

- non-pressurized



Please note

The cooling water does not change between inlet and outlet, except for the temperature (warming up to 35°C possible), and can be further used for refilling the basin. (Back pressure 0,5 bar max.)

4.3.6 Interface water softener drain

Pressure

- non-pressurized

4.3.7 Additional tools

The following additional tools are required for start-up and for maintenance:

- Rotating field measuring device
- Multimeter
- Clamp-on ammeter
- Flow-rate meter, e.g. Kestrel 1000
- Thermometer
- Salinometer, density range 1.180 to 1.240 g/cm³
- Titration kit for chlorine
- Stop watch
- Aluminium straight edge (2 m long)

4.4 Mechanical installation



Warning!

Risk of injury or damage to the system!

Only authorized specialized personnel qualified for installation and start-up may install the chlorine membrane electrolysis system. All electrical work on the chlorine membrane electrolysis system may only be performed by qualified electricians. Modifications to the system which go beyond those described in this manual are not permissible. (See also chapter 2.2 General safety instructions)



Please note

The basis of all installation work are the drawings contained in chapters 7. and 8. Components and hose connections that are mechanically or electrically operated are labeled on the system with abbreviations (e.g. M3). To facilitate their identification, these abbreviations are repeated at relevant points in the operating instructions and on the drawings.

4.4.1 Setup

Taking into account the requirements on the setup location listed under chapter 4.3.1 Installation room, set up the chlorine membrane electrolysis system and its necessary accessories as shown in the dimension drawing chapter 7.:

Chlorine membrane electrolysis system

- 1 Move the chlorine membrane electrolysis system to its final position.



Please note

Install chlorine membrane electrolysis system so that it is accessible and visible from all four sides and so that sufficient space is available for maintenance work.

- 2 Replace transport rollers with hinged feet (provided in accessories set); to do this
- 3 Jack-up the system using a lifting truck or another suitable device.
- 4 Dismantle the four transport rollers using spanner SW17.
- 5 Assemble the four hinged feet using spanners SW14 and SW17. Minimum screw-in depth 15 mm.
- 6 Lower chlorine membrane electrolysis system to the floor.
- 7 Level the system using a spirit level.

- 8 Tighten the nuts to secure the hinged feet.
- 9 Stick together with PVC adhesive the elbow connector of the hydrogen vent pipe and the sleeve at the blow-out head.



Warning!

Risk of injury!

The elbow connector must be sealed gas-tight and may not show downwards. Make sure that the hydrogen vent pipe is installed in a continuous upward gradient.

- 10 Create connection between safety overflow of the salt dissolving tank and sewage water system. Lay the PVC hose (provided as standard accessory of the system) at a steadily falling angle and without pressure.

- 11 Create connection between safety overflow mechanism of the sodium hypochlorite storage tank and sewage water system. Lay the PVC hose (provided as standard accessory of the system) at a steadily falling angle and without pressure.



Please note

The sodium hypochlorite solution must be disposed of in accordance with the local regulations!

Collecting basin

For setting up a collecting basin, the same conditions apply as for the chlorine membrane electrolysis system.



Please note

The leak sensor of the chlorine membrane system works along with a collecting basin only. We recommend always installing a collecting basin. In this matter, observe the local regulations!

Remove transport plugs

Remove all of the transport plugs from the hose connections and the chlorine membrane electrolysis system.

4.4.2 Installation of the connections

See chapter 8. Arrangement of components.



Please note

All transport plugs have to be removed!
The electrolysis cells are filled with softened water during transport. Water may therefore escape when the connections are installed!

The following connections must be made in accordance with the drawings and the instructions (yellow labels) on the system:

Connection	DN	d	Connection type	Material	Comments
Operating water inlet (A1)	15	20	3/4"-thread	PVC hose 13.5 x 3.5	
Cooling water outlet (A2)	10	16	1/2"-thread	PVC hose 6 x 3	non-pressurized
Softening process flush (A6)	10	16	3/4"-thread	PVC hose 10 x 3	Waste water connection without pressure into sewage system
Hydrogen vent pipe (A7)	100	110	Pipe 100 x 5,3	Hydrogen vent hose d 110 Plastic pipe DN 100	Connect hydrogen vent hose to elbow connector. Connect hydrogen vent hose to plastic pipe DN 100 and use a hose clamp to prevent hydrogen vent hose from slipping off.



Please note

When setting up connections, please note the ambient conditions, chapter 4.3.



Warning!

Risk of explosion!

Leaks may release hydrogen. Hydrogen combines with air to create an explosive mixture and is highly flammable. To ensure safe, trouble-free operation, it is imperative to follow the assembly instructions given in chapter 4.3.4 Interface hydrogen vent pipe.

4.4.3 Installing the air flow monitor

Install the air flow monitor immediately before the position where the hydrogen vent pipe leaves the building. The air flow monitor may only be installed in a vertical tube.

Proceed as follows:



Attention!

Risk of injury!

Note the flow rate according to the red arrow on the air flow monitor!

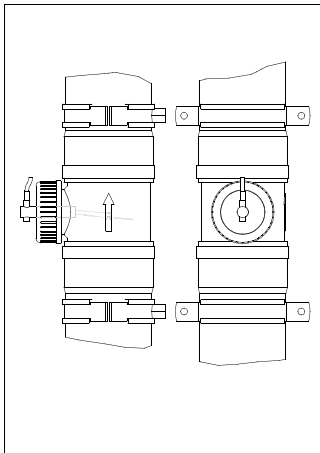

- 1 Connect the hydrogen vent pipe to the air flow monitor from below using a plug-in sleeve or slip-on sleeve.
- 2 Install air flow monitor in a vertical tube.
- 3 Reconnect the air flow monitor to the hydrogen vent pipe after or above the air flow monitor using a plug-in sleeve or slip-on sleeve.
- 4 Attach a pipe clamp directly before and after the air flow monitor.
- 5 Concerning the electrical installation of the air flow monitor see chapter 4.5.2 Connecting inputs, and chapter 9. Wiring diagram.

Fig. 1 Installation position of the air flow monitor



Please note

Push the plug-in sleeve or slip-on sleeve all the way onto the air flow monitor. Ensure that the plug-in sleeve or slip-on sleeve and the seals are all securely seated!

4.5 Electrical installation



Warning!

Risk of injury!

Only authorized and qualified electrical technicians may electrically connect the chlorine membrane electrolysis system. Connect the control cabinet in accordance with the electrical terminal diagrams and the applicable national and local regulations.

4.5.1 Checking the power supply

Check that the required power supply 1/N/PE AC 230 V, 50/60 Hz (max. permitted voltage tolerance $V_{\text{eff}} + 10\% / - 10\%$) is available and that the necessary external protective devices are installed.

4.5.2 Connecting the inputs

Arrange the inputs of the relevant design type in accordance with the specifications in the electrical terminal diagram in chapter 9.

There are inputs that must be connected and inputs which it is optional to connect:

Input	Contact	Voltage	State	Switching function	Need
Chlorine gas alarm	Closer	voltage-free	closed	opens on gas alarm	optional
External water softener	Closer	voltage-free	closed	opens on occurrence of fault	optional
External residual hardness control device	Closer	voltage-free	closed	opens on occurrence of residual hardness > 0	optional
Dosing area leak monitoring	Opener	voltage-free	closed	opens when leaks occur	optional
Storage tank leak monitoring	Opener	voltage-free	closed	opens when leaks occur	optional
Air flow monitor	Closer	voltage-free	closed	opens on occurrence of fault	required
Release preparation / preparation off	Closer	voltage-free	closed	opens to end preparation	optional
Release system / EMERGENCY STOP	Closer	voltage-free	closed	opens for EMERGENCY STOP system	optional



Please note

In case not bridged by the manufacturer, all unnecessary connections must be bridged.

The following power supplies are provided for the chlorine gas warning device.

Consumer units	Voltage	max. power
Chlorine gas leak detector	1/N/PE/ AC 230 V, 50 Hz	60 VA



Please note

Evoqua recommends that you should always use a chlorine gas leak detector!

4.5.3 Connecting the outputs

Arrange the outputs of the relevant design type in accordance with the specifications in the electrical terminal diagram in chapter 9.

Connection of all outputs is optional:

Output	Contact	Voltage	State	Switching function	Need
Flashing alarm light	Transistor output	DC 24 V	inactive	active when faults occur	optional
Chlorine gas alarm	Change-over contact	voltage-free	active	inactive on gas alarm	optional
Alarm relay 1	Change-over contact	voltage-free	inactive	active in the "preparation active" state	optional
Alarm relay 2	Change-over contact	voltage-free	active	inactive when fault occurs	optional
Release Dosing/decanting	Change-over contact	voltage-free	inactive	active when the level is < storage tank fill level "min."	optional
Metering lock Dosing pump 1	Opener	voltage-free	inactive	opens when level is < storage tank fill level "empty"	optional
Metering lock Dosing pump 2	Opener	voltage-free	inactive	opens when level is < storage tank fill level "empty"	optional

4.5.4 Connecting the Process Monitoring System

The Evoqua visualization system is installed in the control cabinet as an option and is connected to the chlorine membrane electrolysis system via the RS485 bus interface.

Connect the Process Monitoring System locally to an analog telephone line with its own number.

If you wish, you can also connect the Process Monitoring System to the local network via a network cable.

There is a separate operating manual for Process Monitoring System, which can be ordered from Evoqua Water Technologies GmbH if required.

Part No.	Language
W3T166939	German
W3T159186	English
W3T159187	French

4.5.5 Connecting the interfaces

Connect the interfaces for the Evoqua RS485 bus and the Profibus DP as specified in the wiring diagram which can be found in chapter 9.. Connection to a Profibus DP network is described in detail in chapter 4.8 Connecting to Profibus DP, the RS485 bus interface in chapter 4.9.

4.5.6 Connecting the power supply

Connect the mains cable in accordance with the specifications of the electrical terminal plan in chapter 9.



Attention!

Risk of injury and damage to the system!

The main switch must remain sealed until start up begins! Only Evoqua service personnel or personnel who have been trained and authorized by Evoqua for installation and start-up may open the seal on the main switch and start the chlorine membrane electrolysis system.

4.6 Completing the acceptance certificate

The installation work must be checked against the acceptance certificate for the installation VD300-1 by Evoqua service personnel or personnel who have been trained and authorized by Evoqua. The acceptance certificate must be correctly completed, signed and returned to Evoqua.

The chlorine membrane electrolysis system may only be put into operation if it has a correctly completed, signed acceptance certificate that is free of complaints or objections.

4.7 Start-up



Attention!

Risk of injury and damage to the system!

Only Evoqua service personnel or authorized personnel who have been trained by Evoqua for installation and start-up may open the seal on the main switch and put the chlorine membrane electrolysis system into operation.



Please note

The chlorine membrane electrolysis system may only be put into operation on presentation of the acceptance certificate for the installation VD300-1 that is free of complaints or objections. In the event of any complaints, contact Evoqua customer services immediately.



Warning!

Chemical hazard!

A substantial quantity of chemicals is produced in the chlorine membrane electrolysis system. For safe operation and to prevent harm to persons, be sure to follow the safety instructions and warnings on the system and in this operating manual. (Also see chapter Safety, 2.3 Handling chemicals)



Please note

When planning your schedule, please allow time to wait for 4 hours after filling the salt dissolving tank with softened water to allow the brine to become sufficiently concentrated.



Please note

Components and hose connections that are mechanically or electrically operated are labeled on the system with abbreviations (e.g. M 3). To facilitate identification, these abbreviations are repeated at relevant points in the operating manual and on the drawings.

4.7.1 Procedure

The procedure of the start-up is specified in the start-up checklist VD302-1. Always perform the steps in the process in the order specified. Details on performing the various steps of the start-up procedure are given in the following chapters.

The start-up checklist must be correctly completed, signed and returned to Evoqua Water Technologies GmbH (this is a precondition for the customer to be able to make claims for defects).

4.7.2 Preparing tools for start-up

The following parts from the standard accessories are required for start-up:

- W3T166135 drum pump, complete
- W3T161174 sodium hydroxide 4 - 6 %, 30 liters
- W3T161077 9% hydrochloric acid, 10 litres
- W3T169285 water hardness test kit

The following additional tools are also required:

- Flow-rate measuring device (e.g. Kestrel 1000)
- Thermometer
- Multimeter
- Rotating field measuring device
- Salinometer, density range 1.180 to 1.240 g/cm³

4.7.3 Preparing the salt dissolving tank



Attention!

To ensure fault-free, safe operation, use only the salt prescribed by the manufacturer (e. g. Evoqua OSEC® Salin) and completely softened water produced by the chlorine membrane electrolysis system.

Proceed as follows:

- 1 Fill the salt dissolving tank with salt. Make sure that no salt falls onto the mounting frame. The fill level in the salt dissolving tank should be between 30 and 40 cm.

4.7.4 Removing the seal on the main switch



Attention!

Risk of injury and damage to the system!

Only authorized personnel who have been trained by Evoqua for installation and start-up may remove the seal on the main switch!

4.7.5 Turning the chlorine membrane electrolysis system on

Proceed as follows:

- 1 Turn on chlorine membrane electrolysis system at main switch.

The following will happen:

- The internal initialization is displayed. Then the language selection dialog box is displayed for 10 seconds. The factory default setting is German.
 - At the same time the automatic stopcock (E1) is opened.
- 2 Select the required language. The display then switches to the start-up menu.

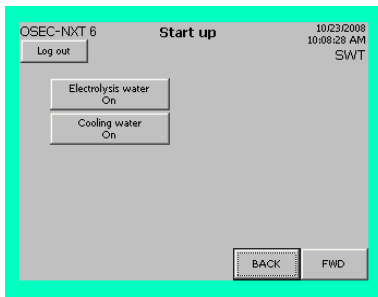
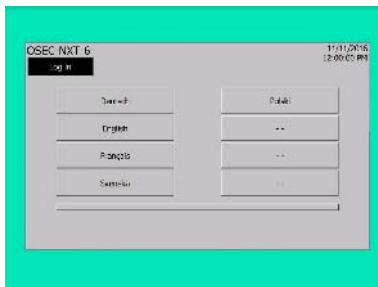

- 3 Log in. Enter the level 3 "Service personnel" password and user name. (For details, see chapter 5.2.2 Logging in.)



Please note

Next, check the operating water pressure and adjust if necessary. See the next chapter 4.7.6 Checking operating water pressure.

4.7.6 Checking operating water pressure

Check the operating water pressure and adjust if necessary:

Designation	Ref.	Setting
Operating water pressure reducing valve	M3	3.5 bar



Please note

Follow the instructions on the display!

4.7.7 Setting the electrolysis water flow rate

Proceed as follows:

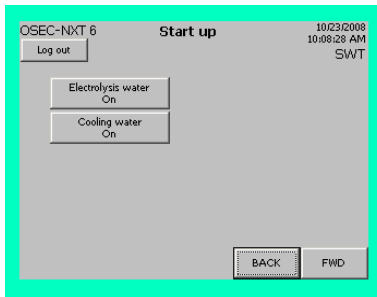

- 1 Press the "Electrolysis water On" button on the display. The button will then change to "Electrolysis water Off".
- 2 Set the system-specific electrolysis water flow rate using the electrolysis water flow meter (M7). Read the flow rate off the top of the ball. The operating water flow rate for the OSEC-NXT 6 is 12 l/h. See the information label on the chlorine membrane electrolysis system.



Please note

Check the operating water pressure at the operating water pressure reducing valve (M3) and adjust if necessary.

- 3 Then measure the total water hardness of the softened water.

4.7.8 Measuring the softened water hardness

Proceed as follows:

- 1 Take water sample at the soft water sample ball valve (M8).
- 2 Measure the water hardness using the test kit provided, as described in the test kit instruction manual.
- 3 Enter the measured value in the start-up checklist.



Attention!

The soft water hardness should be < 0.25° dH. If not, contact Evoqua customer services.

- 4 Press the "Electrolysis water Off" button on the display. The button will then change to "Electrolysis water On".
- 5 Press the "FWD" button to continue.

4.7.9 Measuring the operating water hardness

Proceed as follows:

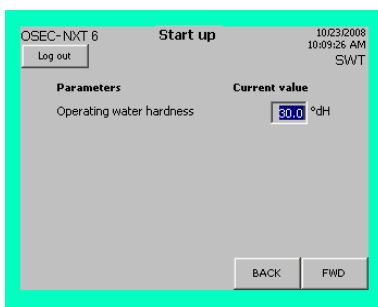

- 1 Take a water sample at the filter drain tap of the pressure reducing valve (M5).
- 2 Measure the water hardness using the test kit provided, as described in the test kit instruction manual.
- 3 Enter the water hardness, which should be between 0 and 66° dH, on the display. The factory default setting is 30° dH. The regeneration counts of the water softener are determined on the basis of the entered water hardness value.
- 4 Enter the measured value in the start-up checklist.
- 5 Press the "FWD" button to continue. This also starts filling the salt dissolving tank.

4.7.10 Filling the salt dissolving tank

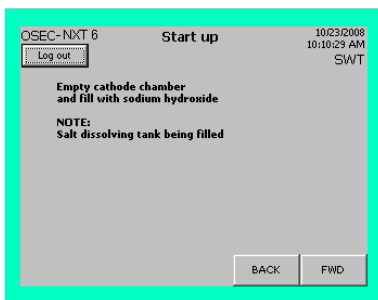

Next, the salt dissolving tank is filled with softened water up to the level limit.



Please note

When planning your schedule, please allow time to wait for 4 hours after filling the salt dissolving tank with softened water to allow the brine to become sufficiently concentrated.

4.7.11 Emptying the water-filled cathode chamber and filling with sodium hydroxide



Attention!

Damage to the electrolysis cell!

Empty the cathode chamber and refill immediately!
Never empty the cathode and anode chambers at the same time!
The membrane could dry out and damage the electrolysis cell!

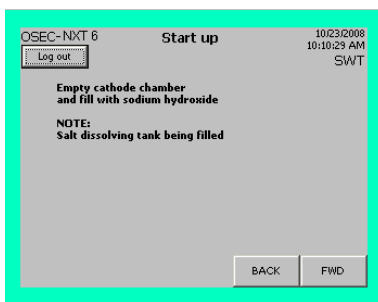

Proceed as follows:

- 1 Prepare sodium hydroxide and the drum pump from the standard accessories.
- 2 Connect the cathode-side outlet drain and the sewage system with a hose.
- 3 Open the ball valve (M11) and allow the cathode chamber to run completely empty (softened water from the transport filling).
- 4 Using the drum pump, add sodium hydroxide via the cathode-side drain until it runs out of the sodium hypochlorite pipe into the sodium hypochlorite tank.
- 5 Close the ball valve (M11) on the cathode-side drain immediately after filling to prevent it flowing back into the canister.



Please note

Keep the sodium hydroxide canister for subsequent use.

- 6 Rinse the drum pump with approx. 5 l of softened water.
- 7 Press the „FWD“ button to continue.

4.7.12 Checking the hydrogen vent pipe

Proceed as follows:

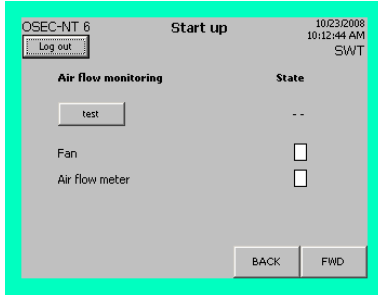

- 1 Check the hydrogen vent pipe is correctly installed and check for leaks (see chapter 4.3.4 Interface hydrogen vent pipe and chapter 4.4.2 Installing the connections).
- 2 Check correct assembly of the air flow monitor (see chapter 4.4.3 Installing the air flow monitor).

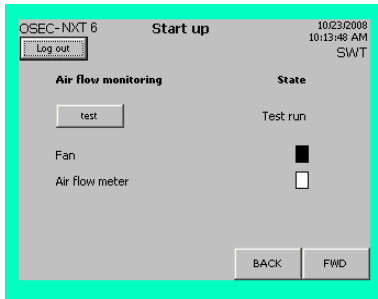

- 3 Press the "test" button to check that the air flow monitor is working correctly.

The fan starts turning and the corresponding status indicator changes from white to black.

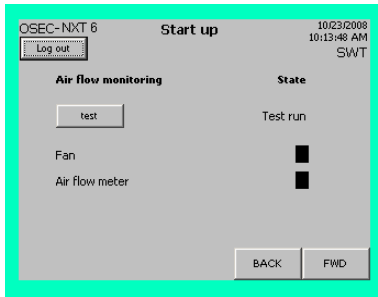

Check that the air flow monitor is working correctly when the fan is on. If air is flowing, the corresponding status indicator changes from white to black.

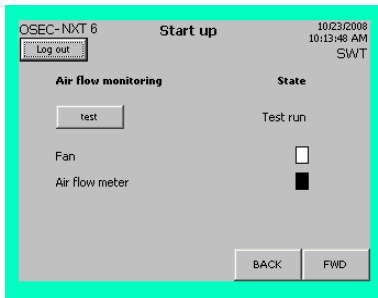

The fan stops. The status indicator changes back from black to white.

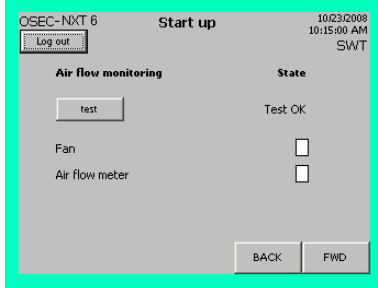

Check that the air flow monitor is working correctly when the fan is off. If air is not flowing, the status indicator changes from black to white. This means that the air flow monitor is working correctly, and the message "Test OK" is displayed.

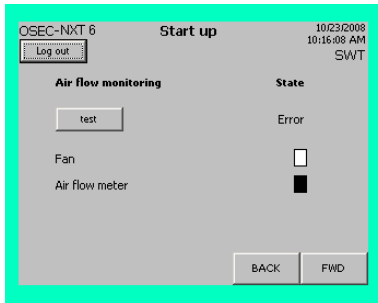

The test takes between 30 seconds and 6 minutes at most. If there is an error once the time limit has been reached, the message "Error" is displayed.

If there is an error:

- Check the installation position of the air flow monitor (see chapter 4.4.3 Installing air flow monitor and 4.3.4 Interface hydrogen vent pipe).
- Check the electrical connection to the air flow monitor
- Discuss further measures with Evoqua



Warning!

Risk of injury!

If the air flow monitor is not working, abort start-up.

- 4 Enter the result of the test in the start-up checklist.
- 5 Press the "FWD" button to continue.

4.7.13

Checking the level switch on the sodium hypochlorite storage tank

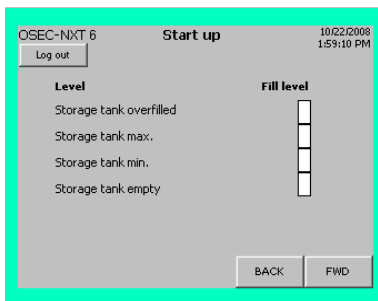

The level switches are installed in the factory. If the sodium hypochlorite storage tank is empty the display should appear as shown on the left.

- 1 Press the "FWD" button to continue.

4.7.14 Checking the brine concentration



Please note

The chlorine membrane electrolysis system may only be operated with saturated brine. The 4 hour waiting period must be observed after filling the salt dissolving tank with softened water!

The brine must have a density of greater than 1.202 g/cm³.

Proceed as follows:

- 1 Take a brine sample at the extraction pipe of the salt dissolving tank and fill into a transparent vessel with a minimum fluid level of 30 cm.
- 2 Insert salinometer into the brine sample and allow to float freely.
- 3 Read the concentration value at the fluid level from the scale.
- 4 If the measured value is less than 1.202 g/cm³, take further measurements every 15 minutes until the required value has been reached.
- 5 Enter a comment in the checklist.

4.7.15 Emptying the water-filled anode chamber and rinsing with acid



Attention!

Damage to the electrolysis cell!

Empty the anode chamber and then rinse with acid immediately to prevent damage to the electrolysis cell.

Proceed as follows:

- 1 Prepare acid and the drum pump from the standard accessories.
- 2 Connect the chlorine separator drain (M9) to the sewage system using a hose.
- 3 Open the chlorine separator drain (M9) and allow the anode chamber to run completely empty (softened water from the transport filling).
- 4 Connect the chlorine separator drain to the drum pump with a hose.
- 5 Pump 9% hydrochloric acid into the anode chamber using the drum pump until the fill level in the chlorine separator is steady above the top of the electrolysis cell.

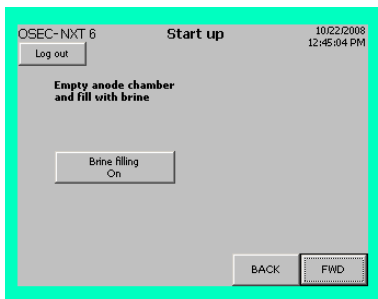

- 6 Switch the pump off as soon as the fill level is reached.



Attention!

Risk of injury and damage to the system!

Do not allow any acid to enter the reactor via the overflow pipe!

- 7 Close the chlorine separator drain (M9) immediately after filling to prevent it flowing back into the canister.
- 8 Rinse the drum pump with approx. 5 l of softened water.
- 9 Wait 15 minutes open the chlorine separator drain (M9), drain the acid from the anode chamber and dispose of.
- 10 Close the chlorine separator drain (M9).



Please note

The anode chamber must be filled with brine immediately after being rinsed with acid. The unit must be started immediately (within approx. 1 hour) after being rinsed with acid!

4.7.16

Filling the anode chamber with brine



Attention!

Damage to the system!

The anode chamber must be filled with brine immediately after being rinsed with acid. The anode chamber may only be filled with saturated brine!

Proceed as follows:

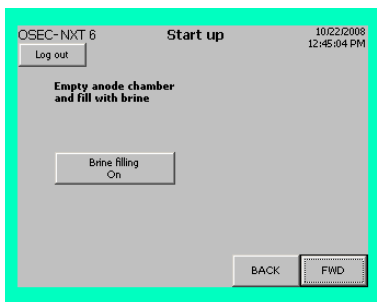

- 1 Press the "Brine filling On" button on the display. The button will then change to "Brine filling Off". When the fluid level limit is reached in the chlorine separator the brine pump stops automatically. The manual brine pump function is simultaneously turned off. The button will then change back to "Brine filling On".
- 2 Press the "FWD" button to continue.



Please note

The unit must be started immediately (within approx. 1 hour) after being rinsed with acid.

4.7.17 Finishing start-up



Attention!

Damage to the electrolysis cell!

Start-up must be completed within two hours of the anode chamber having been filled with saturated brine to prevent damage to the electrolysis cell.

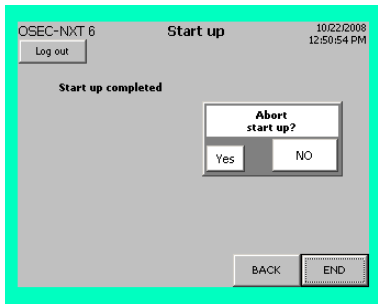

Start-up is now complete.

If necessary, press "BACK" to go back to any stage of the process.

If all of the tasks have been completed, leave the start-up menu:

- 1 Press the "END" button.
- 2 "Finish start-up?" Press "Yes".



Please note

If you exited the start-up process accidentally you can resume it by pressing "Shut-down" in the service menu.

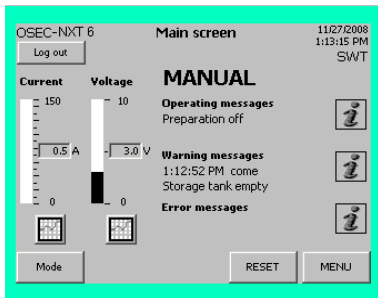

The chlorine membrane electrolysis system is in "MANUAL" mode, in the „Preparation off“ operating state. The system is now ready to operate.

The following will happen:

- All of the control system's control functions are activated.
- Protection potential is switched on.
- If the sodium hypochlorite storage tank is empty the warning "Storage tank empty" is displayed.
- If there is a fault, an error message is displayed. Correct the fault then cancel the error message. See Operation, 5.14 Faults for details.

If there are no faults, press the "Mode" button to switch the chlorine membrane electrolysis system to automatic mode. The automatic preparation process starts.

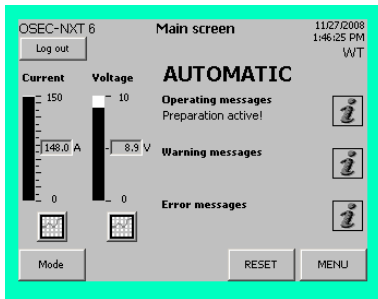

If the level in the sodium hypochlorite storage tank is below "Storage tank min." the chlorine membrane electrolysis system will switch to the "Preparation active" state.

If the fluid level limit in the chlorine separator has not been reached, the brine pump starts. When the fluid level limit is reached the following events occur.

- The brine pump is turned off.
- The electrolysis water solenoid valve (E2) is opened.
- The cooling water solenoid valve (E3) is opened.
- The electrolysis current is switched on and the voltage increases until the electrolysis power is reached.

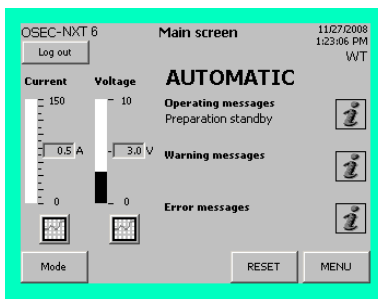

Once electrolysis power is reached, the chlorine membrane electrolysis system switches to the product preparation state and prepares sodium hypochlorite until the "Storage tank max." level is reached in the sodium hypochlorite storage tank. Then the system remains in the "Preparation standby" state. For details see chapter Operation, 5.3 Automatic operation.

4.7.18 Completing the final tasks

- Measure the air flow at the vent opening
- Check and if necessary, adjust the operating water pressure
- Perform titration once the system has been running for approx. 30 min. For further details see chapter Maintenance, 6.3.3 Checking the product concentration.
- Replace covers
- Complete and sign the start-up checklist and send to Evoqua Water Technologies GmbH (this constitutes part of the liability for defects).

Measure the air flow at the vent opening

Proceed as follows:

- 1 Measure the air flow rate at the vent opening using an air flow meter, e.g. the Kestrel 1000, in accordance with the meter manufacturer's instructions.



Please note

The measured air flow rate must be at least the required minimum flow rate of 3.5 m/s.



Attention!

Before leaving the installation site, monitor the system for at least 30 minutes!

4.7.19 Training and instructing operators

Train and instruct the operators with the help of the instruction manual, and in particular the chapters on Safety, Operation and Faults.

Training and instruction must be checked against the instruction acceptance certificate VD307. The acceptance certificate must be correctly completed, signed and returned to Evoqua Water Technologies GmbH (this is a precondition for the customer to be able to make claims for defects).



Attention!

Damage to the system!

Before commencing training, log out of the service level and log in using the level 2 user name and password (WT, 9040).



Please note

The operator of the overall system must ensure that only authorized and qualified technicians can work on or with the chlorine membrane electrolysis system, and within their specified area of responsibility.



Please note

Anyone working with the chlorine membrane electrolysis system must have read and understood the instruction manual, and, in particular, the safety instructions.

4.8 Connecting to Profibus DP

The chlorine membrane electrolysis system controller, a Siemens SIMATIC S7-300, is capable of data exchange with a higher level Profibus DP network via Profibus DP. The PROFIBUS DP provides the process data as input and output data (see chapter 4.8.4 Data exchange table). The higher level automation system acts as the Profibus DP master.

4.8.1 Technical data

Hardware	SIMATIC S7-300 controller CPU314C - 2DP V3.x
Transmission technology	RS-485 in accordance with the Profibus specifications
Baud rate	Max. 12 Mbit/s, autodetect
Bus address	Default setting 20, Adjustable from 3 - 125
Bus connection	9 pin D-Sub socket
Communication	Cyclic I/O data exchange between the DP master and the DP slave(s).
Configuration	6 x 16 words, data consistency over the entire length 1 x 13 words, data consistency over the entire length 1 x 4 words, data consistency over the entire length

4.8.2 Connecting Profibus DP



Please note

Follow the setup guidelines for Profibus networks such as on network topology, the properties of the bus lines, line termination, max. segment lengths, max. number of stations, transmission rate, use/number of repeaters etc. For information, contact the Profibus User Organization, Evoqua Water Technologies GmbH or the manufacturer of the automation system you are using.



Warning!

Risk of injury or damage to the system!

Electrical work on the chlorine membrane electrolysis system may only be performed by qualified electricians.

Proceed as follows:

- 1 Shut-down the chlorine membrane electrolysis system, see chapter Maintenance, 6.5 Shut-down.
- 2 Open control cabinet.
- 3 Connect the Profibus DP bus cable to interface X2 on the SIMATIC S7-300 using the bus system's 9-pin Profibus DP plug connector.

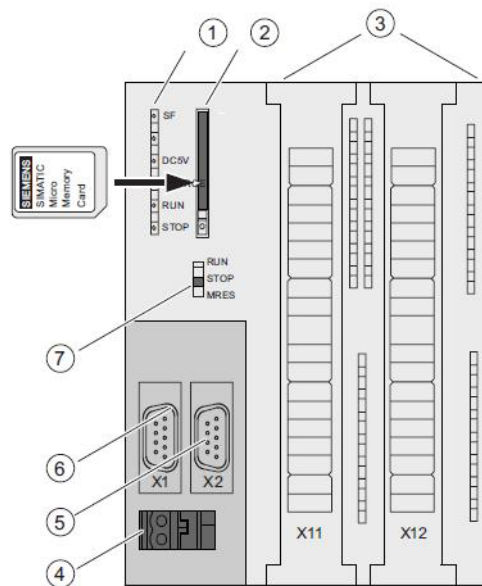

Fig. 2 CPU SIMATIC S7-300

- 1 Status and error messages
- 2 Slot for SIMATIC Micro Memory Card incl. ejector
- 3 Connection to the integrated inputs and outputs
- 4 Power supply connection
- 5 Interface X2 (PtP or DP)
- 6 Interface X1 (MPI)
- 7 Mode selector switch



Please note

Both of the status LEDs "SF" and "BF" on the SIMATIC S7-300 will light up if the chlorine membrane electrolysis system is not connected to a higher level Profibus DP network. This indicates that there is no communication partner (master) connected. This does not have any effect on or prevent the operation of the chlorine membrane electrolysis system.

- 4 Start the chlorine membrane electrolysis system up again, see chapter Maintenance, 6.6 Starting the system up again.

4.8.3 Configuring the Profibus DP master

Data is sent via the Profibus DP in 226 Byte packets (see chapters 4.8.4 Data exchange table and 4.8.5 Data formats for further information).

218 Byte data can be read by the PROFIBUS DP Master (6 x 16 words with data consistency over the entire length and 1 x 13 words with data consistency over the entire length). 8 Byte data can be written by the PROFIBUS DP Master (1 x 4 words, data consistency over the entire length).

Below is a description of how to connect the chlorine membrane electrolysis system to a SIEMENS SIMATIC S7-300 automation system with a Profibus DP interface.

The Profibus DP master is configured using the device master file (GSD file) for the SIMATIC S7-300 CPU314C - 2DP V3.



Please note

If you wish to connect the system to an automation system made by any other manufacturer, e.g. ABB, Mitsubishi, Moeller, etc., please refer to the documentation provided by the manufacturer for the necessary information.

Proceed as follows:

- 1 Download the driver for the GSD file SIMATIC S7-300 CPU314C - 2DP V2.6.
- 2 Insert the controller (A) and connect it to the network.

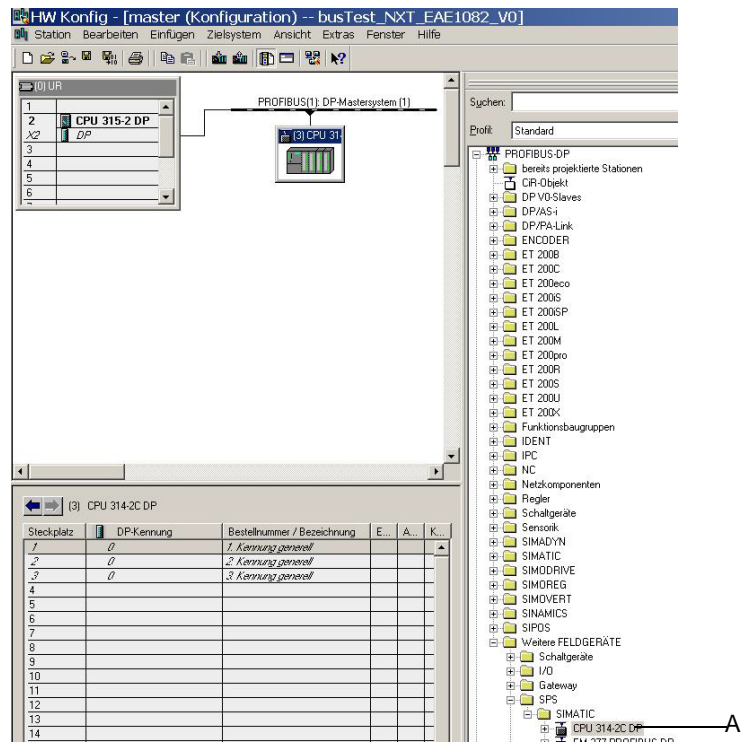

A Control unit

3 Enter the following configuration:

- 6 x 16 words, data consistency over the entire length
- 1 x 13 words, data consistency over the entire length
- 1 x 4 words, data consistency over the entire length

The screenshot shows the HW Konfig software interface for configuring a PROFIBUS DP-Mastersystem. The main window displays a rack configuration for a CPU 314-2C DP. A table below the rack shows the configuration for each slot, including DP-Address, Order Number, and E-Address. A callout 'A' points to the E-Address column.

Steckplatz	DP-Kennung...	Bestellnummer / Bezeichnung	E-Adresse	A-Adresse	Ko...
1	0	1. Kennung generell			
2	0	2. Kennung generell			
3	0	3. Kennung generell			
4	223	Universalmodul	0...31		
5	223	Universalmodul	32...63		
6	223	Universalmodul	64...95		
7	223	Universalmodul	96...127		
8	223	Universalmodul	128...159		
9	223	Universalmodul	160...191		
10	220	Universalmodul	192...217		
11	227	Universalmodul		0...7	
12					
13					
14					
15					

A E-address: Input byte "n" equals "0"



Please note

In the example shown, "n" = "0" (input byte 0). Starting address of the input range for the master.

6 x 16 words

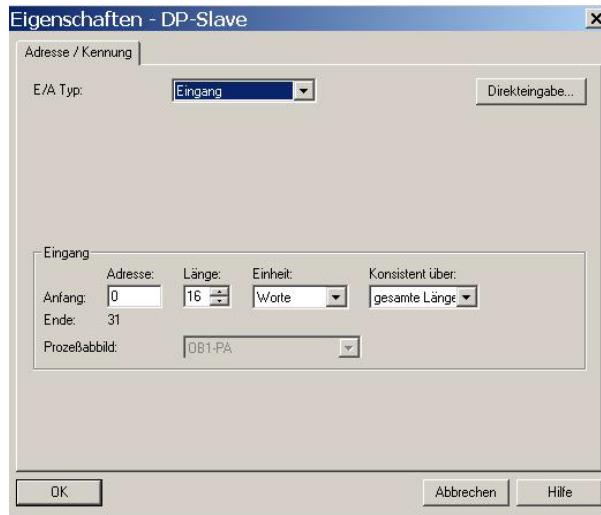

1 x 13 words

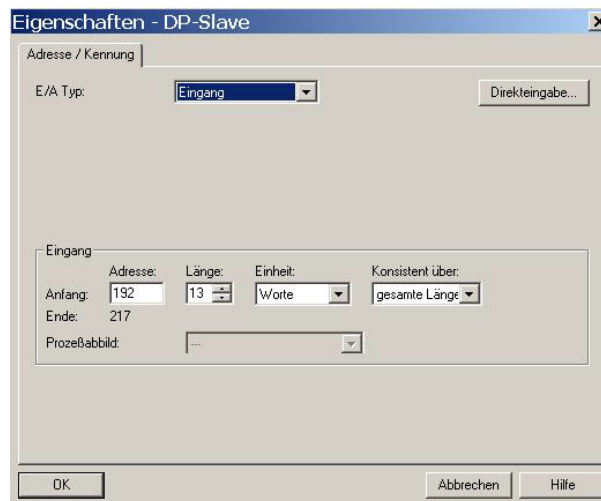

1 x 4 words

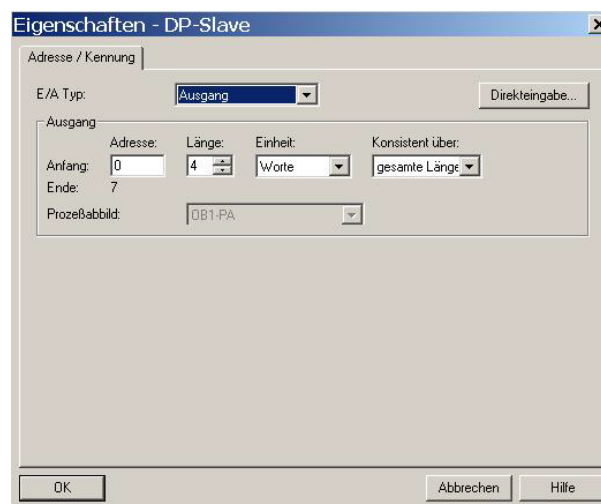

4.8.4 Data exchange table

The data exchange table below lists the data points provided by the chlorine membrane electrolysis system.

Byte address	Bit address	Length (in bytes)	Format	Access	Description
n		10	STRING[8]	R	RS485 bus scan ID
n + 10		6	STRING[4]	R	RS485 bus scan ID
n + 16		12	STRING[10]	R	System type designation
n + 28		10	STRING[8]	R	Software item No.
n + 38		8	STRING[6]	R	Software Version
n + 46		8	STRING[6]	R	Software date, MM/YY
n + 54		18	STRING[16]	R	Serial number
n + 72		18	STRING[16]	R	System location
n + 90		18	STRING[16]	R	System name
n + 108		18	STRING[16]	R	Order number
n + 126		2	WORD	R	**Internal usage, n.c.**
n + 128	0	1	BOOL	R	Message "AUTOMATIC"
n + 128	1		BOOL	R	Message "Preparation standby"
n + 128	2		BOOL	R	Message "Preparation active!"
n + 128	3		BOOL	R	Message "Preparation start up"
n + 128	4		BOOL	R	Message "Preparation running"
n + 128	5		BOOL	R	Message "Preparation shut down"
n + 128	6		BOOL	R	Message "Preparation ext. locked!"
n + 128	7		BOOL	R	Message "Water softener regeneration running"
n + 129	0	1	BOOL	R	Message "Water softener adding brine"
n + 129	1		BOOL	R	Message "Water softener reacting"
n + 129	2		BOOL	R	Message "Water softener washing"
n + 129	3		BOOL	R	Message "Manual mode active!"
n + 129	4		BOOL	R	Message "MANUAL Electrolysis water!"
n + 129	5		BOOL	R	Message "MANUAL Cooling water!"
n + 129	6		BOOL	R	Message "MANUAL Top-up brine!"
n + 129	7		BOOL	R	Unused
n + 130	0	1	BOOL	R	Warning message "Unstable mains voltage/mains failure"
n + 130	1		BOOL	R	Warning message "Check water softener brine flow rate"

Byte address	Bit address	Length (in bytes)	Format	Access	Description
n + 130	2	1	BOOL	R	Warning message "Storage tank empty"
n + 130	3		BOOL	R	Warning message "Electrolysis water check flow rate"
n + 130	4		BOOL	R	Warning message "Cooling water check flow rate"
n + 130	5		BOOL	R	Warning message "Power off for less than 4 hours!"
n + 130	6		BOOL	R	Warning message "Power off for more than 4 hours!"
n + 130	7		BOOL	R	Warning message "Perform monthly maintenance!"
n + 131	0	1	BOOL	R	Warning message "Perform annual maintenance! Service required"
n + 131	1		BOOL	R	Warning message "Ambient temperature too high"
n + 131	2		BOOL	R	Warning message "Operating water pressure too low"
n + 131	3		BOOL	R	Warning message "Operating water pressure too high"
n + 131	4		BOOL	R	Unused
n + 131	5		BOOL	R	Unused
n + 131	6		BOOL	R	Unused
n + 131	7		BOOL	R	Unused
n + 132	0	1	BOOL	R	Error message "Dosing leak"
n + 132	1		BOOL	R	Error message "Brine pump run time exceeded"
n + 132	2		BOOL	R	Error message "Brine pump wait time exceeded"
n + 132	3		BOOL	R	Error message "Chlorine gas alarm"
n + 132	4		BOOL	R	Error message "Water softener brine flow meter plausibility"
n + 132	5		BOOL	R	Error message "Check air flow monitor" (plausibility)
n + 132	6		BOOL	R	Error message "Fan failure"
n + 132	7		BOOL	R	Error message "Rectifier not ready"
n + 133	0	1	BOOL	R	Error message "System leak"
n + 133	1		BOOL	R	Error message "Storage tank leak"
n + 133	2		BOOL	R	Error message "Storage tank overfilled"
n + 133	3		BOOL	R	Error message "Electrolysis water check flow meter" (no signal)
n + 133	4		BOOL	R	Error message "Electrolysis water flow meter plausibility"
n + 133	5		BOOL	R	Error message "Air flow rate too low"
n + 133	6		BOOL	R	Error message "Cell voltage too high"
n + 133	7		BOOL	R	Error message "Electrolysis current too low"
n + 134	0	1	BOOL	R	Error message "Cooling water flow switch plausibility"
n + 134	1		BOOL	R	Error message "Cooling water flow rate too low"

Byte address	Bit address	Length (in bytes)	Format	Access	Description
n + 134	2	1	BOOL	R	Error message "Electrolysis water flow rate too low"
n + 134	3		BOOL	R	Error message "Electrolysis water flow rate too high"
n + 134	4		BOOL	R	Error message "Storage tank level probes plausibility"
n + 134	5		BOOL	R	Error message "EMERGENCY STOP"
n + 134	6		BOOL	R	Error message "External water softener / hardness control failure"
n + 134	7		BOOL	R	Error message "Salt dissolving tank filling time exceeded"
n + 135	0	1	BOOL	R	Error message "Automatic stopcock will not open! Plausibility check?"
n + 135	1		BOOL	R	Error message "Automatic stopcock will not close! Plausibility check?"
n + 135	2		BOOL	R	Error message "Siphon device level probes plausibility"
n + 135	3		BOOL	R	Error message "Siphon device vacuum pump running time exceeded"
n + 135	4		BOOL	R	Error message "Rectifier not ready! Ambient temperature & warning"
n + 135	5		BOOL	R	Error message "Rectifier not ready! Mains & warning"
n + 135	6		BOOL	R	Error message "Electrolysis water flow rate too low! Pressure & warning"
n + 135	7	BOOL	R	Error message "Cooling water flow rate too low! Pressure & warning"	
n + 136	0	1	BOOL	R	Error message "Salt dissolving tank filling time exceeded! Pressure & warning"
n + 136	1		BOOL	R	Error message "Water softener brine flow rate too low! Pressure & warning"
n + 136	2		BOOL	R	Error message "Water softener brine flow rate too low"
n + 136	3		BOOL	R	Unused
n + 136	4		BOOL	R	Unused
n + 136	5		BOOL	R	Unused
n + 136	6		BOOL	R	Unused
n + 136	7	BOOL	R	Unused	
n + 137	0	1	BOOL	R	Unused
n + 137	1		BOOL	R	Unused
n + 137	2		BOOL	R	Unused
n + 137	3		BOOL	R	Unused
n + 137	4		BOOL	R	Unused
n + 137	5		BOOL	R	Unused

Byte address	Bit address	Length (in bytes)	Format	Access	Description
n + 137	6	1	BOOL	R	Unused
n + 137	7		BOOL	R	Unused
n + 138		4	REAL	R	Preparation total [h]
n + 142		4	REAL	R	Preparation avg. [h]
n + 146		4	REAL	R	Preparation count
n + 150		4	REAL	R	Operating hours total [h]
n + 154		4	REAL	R	Cell voltage [V]
n + 158		4	REAL	R	Electrolysis current [A]
n + 162		4	REAL	R	Electrolysis water [l/h]
n + 166		4	REAL	R	Operating water pressure [bar]
n + 170		4	REAL	R	Ambient temperature [°C]
n + 174		4	REAL	R	Unused
n + 178		4	REAL	R	Unused
n + 182		4	REAL	R	Unused
n + 186		4	REAL	R	Unused
n + 190		4	REAL	R	Unused
n + 194		4	REAL	R	Unused
n + 198		4	REAL	R	Unused
n + 202	0	1	BOOL	R	Digital IN, EMERGENCY STOP
n + 202	1		BOOL	R	Digital IN, ext. Water softener/hardness control
n + 202	2		BOOL	R	Digital IN, Release preparation
n + 202	3		BOOL	R	Digital IN, Electrolysis water
n + 202	4		BOOL	R	Unused
n + 202	5		BOOL	R	Digital IN, Vacuum container max
n + 202	6		BOOL	R	Digital IN, Vacuum container min
n + 202	7		BOOL	R	Digital IN, Cooling water
n + 203	0	1	BOOL	R	Digital IN, Chlorine separator
n + 203	1		BOOL	R	Digital IN, Air flow monitor
n + 203	2		BOOL	R	Digital IN, Fan
n + 203	3		BOOL	R	Digital IN, Dosing leak
n + 203	4		BOOL	R	Digital IN, System leak
n + 203	5		BOOL	R	Digital IN, Storage tank leak
n + 203	6		BOOL	R	Digital IN, Storage tank overfilled

Byte address	Bit address	Length (in bytes)	Format	Access	Description
n + 203	7		BOOL	R	Digital IN, Storage tank max.
n + 204	0	1	BOOL	R	Digital IN, Storage tank min.
n + 204	1		BOOL	R	Digital IN, Storage tank empty
n + 204	2		BOOL	R	Digital IN, Salt dissolving tank level
n + 204	3		BOOL	R	Digital IN, Brine flow
n + 204	4		BOOL	R	Digital IN, Rectifier
n + 204	5		BOOL	R	Digital IN, Automatic stopcock open
n + 204	6		BOOL	R	Digital IN, Automatic stopcock closed
n + 204	7		BOOL	R	Digital IN, Chlorine gas alarm
n + 205	0	1	BOOL	R	Unused
n + 205	1		BOOL	R	Unused
n + 205	2		BOOL	R	Unused
n + 205	3		BOOL	R	Unused
n + 205	4		BOOL	R	Unused
n + 205	5		BOOL	R	Unused
n + 205	6		BOOL	R	Unused
n + 205	7		BOOL	R	Digital IN, Mains monitoring
n + 206	0	1	BOOL	R	Digital OUT, Brine pump
n + 206	1		BOOL	R	Digital OUT, Alarm horn
n + 206	2		BOOL	R	Digital OUT, Alarm light
n + 206	3		BOOL	R	Digital OUT, Release metering/decanting
n + 206	4		BOOL	R	Digital OUT, Vacuum pump
n + 206	5		BOOL	R	Digital OUT, Cooling water
n + 206	6		BOOL	R	Digital OUT, Electrolysis water
n + 206	7		BOOL	R	Digital OUT, Fan
n + 207	0	1	BOOL	R	Digital OUT, Salt dissolving tank
n + 207	1		BOOL	R	Digital OUT, Water softener flush
n + 207	2		BOOL	R	Digital OUT, Water softener injector
n + 207	3		BOOL	R	Digital OUT, Water softener inlet
n + 207	4		BOOL	R	Digital OUT, Rectifier
n + 207	5		BOOL	R	Digital OUT, Alarm relay 2
n + 207	6		BOOL	R	Digital OUT, Alarm relay 1
n + 207	7		BOOL	R	Digital OUT, Automatic stopcock

Byte address	Bit address	Length (in bytes)	Format	Access	Description
n + 208		1	BYTE	R	Unused
n + 209		1	BYTE	R	Unused
n + 210		1	BYTE	R	Unused
n + 211		1	BYTE	R	Unused
n + 212		1	BYTE	R	Unused
n + 213		1	BYTE	R	Unused
n + 214		1	BYTE	R	Unused
n + 215	0	1	BOOL	R	User registered via HMI
n + 215	1		BOOL	R	User registered via PROFIBUS DP
n + 215	2		BOOL	R	Unused
n + 215	3		BOOL	R	Unused
n + 215	4		BOOL	R	Unused
n + 215	5		BOOL	R	Unused
n + 215	6		BOOL	R	Unused
n + 215	7		BOOL	R	Unused
n + 216		2	WORD	R	Unused
n + 218		4	DWORD	W	Set password (wt) via PROFIBUS DP
n + 222	0	1	BOOL	W	Change operating mode via PROFIBUS DP
n + 222	1		BOOL	W	Start/stop preparation via PROFIBUS DP
n + 222	2		BOOL	W	Turn on/off manual function electrolysis water via PROFIBUS DP
n + 222	3		BOOL	W	Turn on/off manual function cooling water via PROFIBUS DP
n + 222	4		BOOL	W	Turn on/off manual function brine filling via PROFIBUS DP
n + 222	5		BOOL	W	Activate manual function water softener regeneration via PROFIBUS DP
n + 222	6		BOOL	W	Activate test injector via PROFIBUS DP
n + 222	7		BOOL	W	Unused
n + 223		1	BYTE	W	Unused
n + 224		1	BYTE	W	Unused
n + 225		1	BYTE	W	Unused

- Legend*
- n: Starting address of the input range for the master
 - R: Read access permission
 - W: Write access permission



Please note

In the example shown, "n" = "0" (input byte 0). Starting address of the input range for the master.

4.8.5 Data formats

The table below lists the data formats used to transmit the process data.

Data type	Size (Bit)	Typically called	Signed	Value range	
				min.	max.
BOOL	1	Bit, Bool	No	0	1
BYTE	8	Unsigned char, byte	No	00 _{HEX}	FF _{HEX}
WORD	16	Unsigned integer, word	No	00 _{HEX}	FFFF _{HEX}
REAL	32	Float, real, floating point	Yes	1.175 495E-38	3.402 823E+38
STRING	(nx8) + 16	ASCII, string, character string	No		

n = number of characters

The byte order in the various data types saved in or transferred to the memory is shown below.

BYTE Example: 7B_{hex} = 123_{dec}

BYTE 0							
7B _{hex}							
7	Bit						0
0	1	1	1	1	0	1	1

WORD Example: 3039_{hex} = 12345_{dec}

BYTE 0				BYTE 1										
3039 _{hex}														
15	Bit			8	7	Bit		0						
0	0	1	1	0	0	0	0	0	1	1	1	0	0	1

REAL Example: 3,141593

BYTE 0				BYTE 1				BYTE 2				BYTE 3																							
3,141593																																			
Sign	Exponent								Mantissa																										
31				24	23	Bit			16	15	Bit			8	7	Bit			0																
V	e	e	e	e	e	e	e	e	e	m	m	m	m	m	m	m	m	m	m	m	m	m	m	m	m	m	m								
0	1	0	0	0	0	0	0	0	0	1	0	0	1	0	0	1	1	0	0	0	0	1	1	1	1	1	1	1	1	0	1	1	1	0	0

STRING Example: 'From' STRING[2]

BYTE 0				BYTE 1				BYTE 2				BYTE 3																					
From																																	
max. string length				Actual string length				ASCII value A				ASCII value b																					
31	Bit			24	23	Bit			16	15	Bit			8	7	Bit			0														
0	0	0	0	0	0	0	1	0	0	0	0	0	0	0	1	0	0	1	0	0	0	0	0	0	1	0	1	1	0	0	0	1	0

4.8.6 Setting the Profibus DP slave

Proceed as follows:

Main screen
MENU
Menu selection
Outputs
Interface

INTERFACE

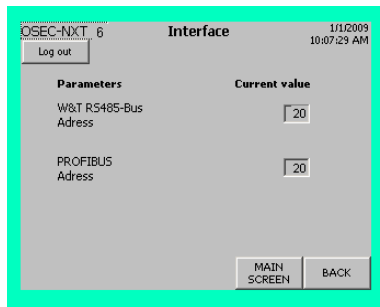

- 1 Switch to the "Interface" screen on the chlorine membrane electrolysis system's control and display unit. The factory setting for the bus addresses is 20. If necessary change the Profibus address. You will be asked to enter a username and password. For details, see chapter 5.2.2 Logging in.



Attention!

Damage to the system!

The setting for the RS485 bus interface must not be changed!

Menu selection
Diagnostics
Info

INFO

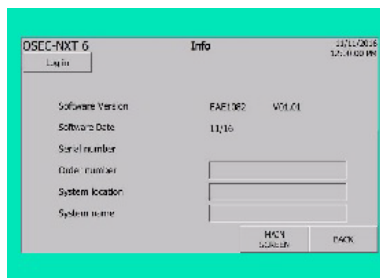

- 2 Press "BACK" to return to the "Menu selection" screen.
- 3 Switch to the "Info" screen. If necessary, enter further details about the chlorine membrane electrolysis system in the "Order number", "System location" and "System name" input boxes. You will be asked to enter a user name and password. For details, see chapter 5.2.2 Logging in.

Proceed as follows:

- 4 Touch the input box you want to access and keyboard will be displayed.
- 5 Enter the number or name and confirm by pressing Enter.

4.9 RS485 bus interface

4.9.1 Version

The standard serial RS485 bus interface in the chlorine membrane electrolysis system is used for data transmission to a PC, web server or an external plant control.

The interface is designed as a symmetrical two-wire bus line according to EIA RS485 (DIN 66259 Part 4 and ISO 8482); it enables data transfer at high transfer rates (19.2 Kbaud) and long distances (up to 1200 m).

Characteristics:

- Allows bidirectional communication
- Two-wire connection (half duplex)
- Bus structure (addressable interface, up to 32 bus addresses)

The interface operates with differential mode voltage signals, ensuring high noise immunity.

The bus system consists of up to 32 passive users (slaves) and one active user (master). Only the active user (computer system) is authorized to start communication. The chlorine membrane electrolysis system unit is always a passive user.

Each user must be assigned a bus address from 0 ... 31. Each bus address may only be assigned once.

4.9.2 Cable

The transmission medium used is a shielded and twisted 2-wire cable (twisted pair) with a wire cross-section of at least 0.22 mm² (e.g. Li2YCY(TP) 2 x 0.22 mm², Ref. No. W2T505559). The shield improves the electromagnetic compatibility (EMC).

The bus cable is always used to connect one user to the next. Stub cables may not exceed 0.3 m.



Please note

Longer junctions in the bus cable are not permitted!

The cable's surge impedance should be between 100 Ohm and 130 Ohm; the cable capacity should be preferably < 60 pF/m and the cross section at least 0.22 mm² (24 AWG) (e.g. Li2YCY(TP) 2 x 0.22 mm², Ref. No. W2T505559).

4.9.3 Interface connection

The RS485 bus interface in the chlorine membrane electrolysis system is connected to the following two terminals:

Bus line A	Terminal A
Bus line B	Terminal B



Please note

The RS485 bus interfaces of the chlorine membrane electrolysis system are galvanically isolated. Each chlorine membrane electrolysis system uses 1 bus address.

4.9.4 Bus terminator

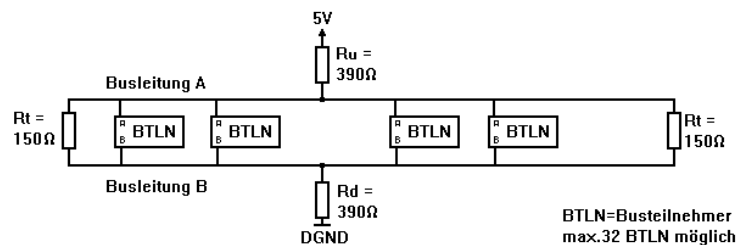

Both ends of the bus cable must be connected to a moving load R_t (150 Ohm). Symmetry is assured at only one point of the bus.

At a voltage supply of 5 V, the R_d and R_u resistors (390 Ohm each) connect to ground and 5 V.

These resistor values apply to a transmission of up to 19200 Bit/s and a maximum bus length of 1200 m.

Symmetry and bus ends should be executed in the same way in potentially isolated and non-isolated bus systems.

4.9.5 Bus design

*Potentially non-isolated
RS485 bus design*

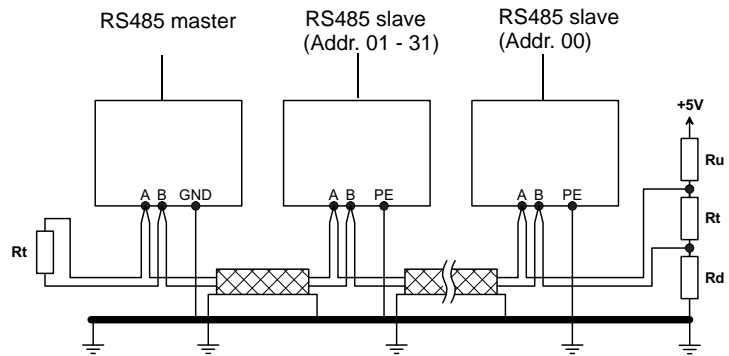

The earth bus or earth electrode conductor $\geq 6 \text{ mm}^2$ must be laid parallel to the bus cable.



Please note

The GND-PE connection is only required for the ChemWeb-Server!

*Potentially isolated
RS485 bus design*

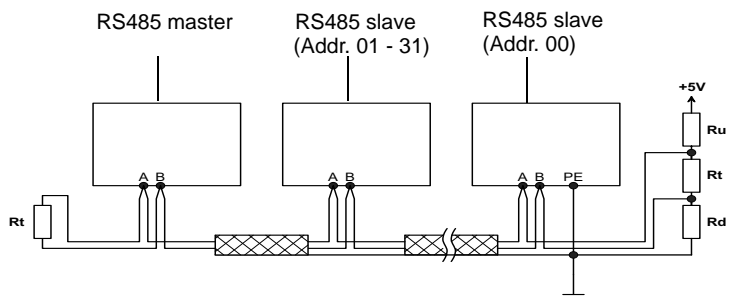

The shield may only be earthed on one side.



Please note

If one bus user is not potentially isolated (e.g. MFC, PCU, DCC), then the bus system must be a potentially non-isolated system! If all of the bus users have an isolated RS485 interface the bus design as described above in the section entitled "Potentially isolated RS485 bus system" can be used.

4.9.6 Specification of the bus interface

Synchronization mode:	Asynchronous
Transmission rate:	19200 baud
Data format (asynchronous):	Start bit: 1 Bit
	Data bit: 8 Bit
	Parity bit: even
	Stop bit: 1 Bit
Signal polarity:	Differential voltage interface Logical "1" = (A-B >= 0.2V) Logical "0" = (A-B <= -0.2V)
Handshake:	No handshake because of request control with fixed blocks
Transmission code:	Wallace & Tiernan protocol (master - slave) multipoint communication, max. 32 users

Not potentially isolated.

4.9.7 Communication protocol

Two different types of frames are used for communication between master (active user, e.g. computer) and slave (passive user):

- Request frame
- Set frame

The slave answers to these frames with the following frames:

- Answer frame
- Positive confirmation
- Negative confirmation

The individual bytes of these frames always have the same format:

- 1 Start bit (always "0")
- 8 Data bits
- 1 Parity bit (even)
- 1 Stop bit (always "1")

4.9.8 Description of the frame bytes

Synchronisation bytes (SYN) The synchronisation bytes are used to synchronise user units to each other.

Start byte (SB) Marks the start of the frame. The value depends on the type of frame:

- Request frame 10H
- Set frame 68H
- Answer frame 68H
- Positive confirmation A2H
- Negative confirmation DCH

Slave address (SA) A unique bus address must be assigned to every module in the RS485 bus (slave address). This can be a number between 0 and 31 decimals.

Destination address (ZA) The destination address determines the transmission variable in the address reference list that is to be read or written.

Check byte The check byte defines the data format and determines which information is read from the slave.

Check byte data format (Bit 0 - 3)

Bit (3210)	Dec.	Format
0000	0	Default (acc. to address reference list)
0001	1	Default (acc. to address reference list)
0010	2	Boolean
0011	3	Boolean
0100	4	Unsigned character
0101	5	Signed character
0110	6	Unsigned integer
0111	7	Signed integer
1000	8	Unsigned long integer
1001	9	Signed long integer
1010	10	Floating point
1011	11	Floating point
1100	12	ASCII
1101	13	ASCII
1110	14	Mixed data format
1111	15	Mixed data format

Additional check byte information (Bit 4 - 7):

Bit (7654)	Function
1000	Min. variable value
0100	Max. variable value
0010	Default variable value
0001	Additional variable information

If a bit is not set in bit 5 - 7, the actual value is written or read. Otherwise, the slave sends the corresponding additional information.

Special case

In the case of "negative confirmation", the check byte includes additional information about the error that has occurred.

In the case of "positive confirmation", the check byte is set to 00Hex.

Value	Function
01H	End of address table
02H	Wrong data format
04H	Additional information not available
08H	Variable to set not within min and max limits
10H	Reading access not permitted
20H	Reading access permitted, but wrong password
40H	Writing access not permitted
80H	Writing access permitted, but wrong password
C0H	Writing access not permitted (e.g. wrong operating mode)

- Number byte (AB)* The number byte defines the number of bytes to read or write. The maximum number per inquiry is 240 bytes!
- Frame check (FC)* The check sum of the frame control bytes is stored in the frame check. $FC = (\text{unsigned char}) SB + SA + ZA + KB + AB$
- Data unit (DU)* The data unit includes the data information to be sent by the slave or master.
- Data check (DC)* The check sum of the frame data bytes is stored in the data check. $DC = (\text{unsigned char}) \text{sum of } DU$
- End byte (EB)* Marks the end of the frame. The value is always 16H.

4.9.9 Request frame

The request frame is necessary to read data or additional information from a slave.

Format of the request frame:

Byte	0-2	3	4	5	6	7	8	9
Name:	SYN	SB	SA	ZA	KB	AB	FC	EB

Byte	Name:	Assignment:
0-2	SYN	Synchronization bytes
3	SB	Start byte 10H
4	SA	Slave address
5	ZA	Destination address
6	KB	Check byte
7	AB	Number byte
8	FC	Frame check
9	EB	End byte 16A

Using the request frame, single words, values spanning multiple addresses, or additional information regarding the destination address can be read. If the contents of a single destination address are requested, the number byte is set to 00Hex. In the answer frame, the data format and the number of bytes is entered from the address reference list into the check byte and the number byte. If a data format is entered into the request frame, it is ignored.

If a number byte is set in the request frame (request spanning multiple addresses), the data format in the answer frame is set to 04H (unsigned char). The answer frame number byte receives the value of the request frame number byte. If a data format is entered into the request frame, it is ignored.

If the additional information of a destination address is requested, the check byte must include the identification for this additional information. The data format and the number byte are ignored. The check byte and the answer byte are set according to the reference list.

Valid request frames are answered with an "answer frame". Invalid request frames are answered with "negative confirmation".

Example:

Requesting the contents of destination address 02H from slave 07H:

00H	00H	00H	10H	07H	02H	00H	00H	19H	16H
SYN	SYN	SYN	SB	SA	ZA	KB	AB	FC	EB

4.9.10 Set frame

The set frame is necessary to write data to a slave.

Set frame format:

Byte	0-2	3	4	5	6	7	8	9-X	Y	Z
Name	SYN	SB	SA	ZA	KB	AB	FC	DU	DC	EB

Byte:	Name:	Assignment:
0-2	SYN	Synchronisation bytes
3	SB	Start byte 68H
4	SA	Slave address
5	ZA	Destination address
6	KB	Check byte
7	AB	Number byte
8	FC	Frame check
9-X	DU	Data bytes
Y	DC	Data check
Z	EB	End byte 16A

Using the set frame, single words or values spanning multiple addresses can be written.

If the contents of a single destination address are written, the number byte must correspond to the number byte from the address reference list. The data format must either be set to "default" or to the data format from the address reference list.

If more variables are to be set spanning multiple addresses, the data format must be set to "default". The number byte contains the number of bytes to write, whereby only whole variables must be written.

Valid set frames are answered by a "positive confirmation". Invalid set frames are answered by a "negative confirmation".

Example:

Setting the contents of destination address 02H interface password) of slave 07H to 904 (dez).

00H	00H	00H	68H	07H	02H	06H	02H	79H	03H	88H	8BH	16H
SYN	SYN	SYN	SB	SA	ZA	KB	AB	FC	DU	DU	DC	EB



Please note

To set parameters via the RS485 bus interface, such as setpoints, it is absolutely necessary to set the interface password (ZA = 02) to the value 904 (decimal) or 0388 (hexadecimal) beforehand.

4.9.11 Answer frame

The answer frame is transmitted by the slave as a result of a master request frame.

Format of the answer frame:

Byte	0-2	3	4	5	6	7	8	9-X	Y	Z
Name:	SYN	SB	SA	ZA	KB	AB	FC	DU	DC	EB

Byte	Name:	Assignment:
0-2	SYN	Synchronization bytes
3	SB	Start byte 68H
4	SA	Slave address
5	ZA	Destination address
6	KB	Check byte
7	AB	Number byte
8	FC	Frame check
9-X	DU	Data bytes
Y	DC	Data check
Z	EB	End byte 16A

If a data format and number byte is not set in the request frame in the check byte, the data format and the byte number are entered into the answer frame from the address list.

Example:

Request frame

00H	00H	00H	10H	07H	02H	00H	00H	19H	16H
SYN	SYN	SYN	SB	SA	ZA	KB	AB	FC	EB

Answer to the example request frame

00H	00H	00H	68H	07H	02H	06H	02H	79H	00H	00H	00H	16H
SYN	SYN	SYN	SB	SA	ZA	KB	AB	FC	DU	DU	DC	EB

4.9.12 Positive and negative confirmation

The "positive confirmation" is transmitted by the slave if a master set frame has been executed validly. A "negative confirmation" is sent by the slave if a set frame or a request frame could not be executed validly.

Positive/negative confirmation format:

Byte:	0-2	3	4	5	6	7	8	9
Name:	SYN	SB	SA	ZA	KB	AB	FC	EB

Byte:	Name:	Assignment:
0-2	SYN	Synchronisation bytes
3	SB	Positive: Start byte A2H Negative: Start byte DCH
4	SA	Slave address
5	ZA	Destination address
6	KB	Check byte
7	AB	Number byte
8	FC	Frame check
9	EB	End byte 16A

The control byte contains 00Hex in the case of a positive confirmation and an error code for a negative confirmation.

Example:

Positive confirmation:

00H	00H	00H	A2H	07H	02H	00H	00H	ABH	16H
SYN	SYN	SYN	SB	SA	ZA	KB	AB	FC	EB

Example:

Negative confirmation:

00H	00H	00H	DCH	07H	02H	02H	00H	E7H	16H
SYN	SYN	SYN	SB	SA	ZA	KB	AB	FC	EB

4.9.13 Address reference list

Addr.	Byte Address	Length (Byte)	Format	Range	Unit	Status	Description
0	0	10	ASCII[8]			R	RS485 bus scan ID
1	10	6	ASCII[4]			R	RS485 bus scan ID
2	16	12	ASCII[10]			R	System type designation
3	28	10	ASCII[8]			R	Software item No.
4	38	8	ASCII[6]			R	Software version
5	46	8	ASCII[6]			R	Software date, MM/YY
6	54	18	ASCII[16]			R	Serial number
7	72	18	ASCII[16]			R	System location
8	90	18	ASCII[16]			R	System name
9	108	18	ASCII[16]			R	Order number
10	126	2	UINT	0...999		R	**Internal usage, n.c.**
11	128.0	1	CHAR			R	Message "AUTOMATIC"
	128.1					R	Message "Preparation standby"
	128.2					R	Message "Preparation active!"
	128.3					R	Message "Preparation start up"
	128.4					R	Message "Preparation running"
	128.5					R	Message "Preparation shut down"
	128.6					R	Message "Preparation ext. locked!"
	128.7					R	Message "Water softener regeneration running"
12	129.0	1	CHAR			R	Message "Water softener adding brine"
	129.1					R	Message "Water softener reacting"
	129.2					R	Message "Water softener washing"
	129.3					R	Message "Manual mode active!"
	129.4					R	Message "MANUAL Electrolysis water!"
	129.5					R	Message "MANUAL Cooling water!"
	129.6					R	Message "MANUAL Top-up brine!"
	129.7					R	Unused
13	130.0	1	CHAR			R	Warning message "Unstable mains voltage/mains failure"
	130.1					R	Warning message "Check water softener brine flow rate"
	130.2					R	Warning message "Storage tank empty"
	130.3					R	Warning message "Electrolysis water check flow rate"

Addr.	Byte Address	Length (Byte)	Format	Range	Unit	Status	Description
13	130.4	1	CHAR			R	Warning message "Cooling water check flow rate"
	130.5					R	Warning message "Power off for less than 4 hours!"
	130.6					R	Warning message "Power off for more than 4 hours!"
	130.7					R	Warning message "Perform monthly maintenance!"
14	131.0	1	CHAR			R	Warning message "Perform annual maintenance! Service required"
	131.1					R	Warning message "Ambient temperature too high"
	131.2					R	Warning message "Operating water pressure too low"
	131.3					R	Warning message "Operating water pressure too high"
	131.4					R	Unused
	131.5					R	Unused
	131.6					R	Unused
	131.7					R	Unused
15	132.0	1	CHAR			R	Error message "Dosing leak"
	132.1					R	Error message "Brine pump run time exceeded"
	132.2					R	Error message "Brine pump wait time exceeded"
	132.3					R	Error message "Chlorine gas alarm"
	132.4					R	Error message "Water softener brine flow meter plausibility"
	132.5					R	Error message "Check air flow monitor" (plausibility)
	132.6					R	Error message "Fan failure"
	132.7					R	Error message "Rectifier not ready"
16	133.0	1	CHAR			R	Error message "System leak"
	133.1					R	Error message "Storage tank leak"
	133.2					R	Error message "Storage tank overfilled"
	133.3					R	Error message "Electrolysis water check flow meter" (no signal)
	133.4					R	Error message "Electrolysis water flow meter plausibility"
	133.5					R	Error message "Air flow rate too low"
	133.6					R	Error message "Cell voltage too high"
	133.7					R	Error message "Electrolysis current too low"
17	134.0	1	CHAR			R	Error message "Cooling water flow switch plausibility"
	134.1					R	Error message "Cooling water flow rate too low"
	134.2					R	Error message "Electrolysis water flow rate too low"

Addr.	Byte Address	Length (Byte)	Format	Range	Unit	Status	Description
17	134.3	1	CHAR			R	Error message "Electrolysis water flow rate too high"
	134.4					R	Error message "Storage tank level probes plausibility"
	134.5					R	Error message "EMERGENCY STOP"
	134.6					R	Error message "External water softener / hardness control failure"
	134.7					R	Error message "Salt dissolving tank filling time exceeded"
18	135.0	1	CHAR			R	Error message "Automatic stopcock will not open! Plausibility check?"
	135.1					R	Error message "Automatic stopcock will not close! Plausibility check?"
	135.2					R	Error message "Siphon device level probes plausibility"
	135.3					R	Error message "Siphon device vacuum pump running time exceeded"
	135.4					R	Error message "Rectifier not ready! Ambient temperature & warning"
	135.5					R	Error message "Rectifier not ready! Mains & warning"
	135.6					R	Error message "Electrolysis water flow rate too low! Pressure & warning"
	135.7					R	Error message "Cooling water flow rate too low! Pressure & warning"
19	136.0	1	CHAR			R	Error message "Salt dissolving tank filling time exceeded! Pressure & warning"
	136.1					R	Error message "Water softener brine flow rate too low! Pressure & warning"
	136.2					R	Error message "Water softener brine flow rate too low"
	136.3					R	Unused
	136.4					R	Unused
	136.5					R	Unused
	136.6					R	Unused
	136.7					R	Unused
20	137.0	1	CHAR			R	Unused
	137.1					R	Unused
	137.2					R	Unused
	137.3					R	Unused
	137.4					R	Unused
	137.5					R	Unused
	137.6					R	Unused
	137.7					R	Unused

Addr.	Byte Address	Length (Byte)	Format	Range	Unit	Status	Description
21	138	4	FLOAT	0...999999,9	h	R	Preparation total [h]
22	142	4	FLOAT	0...999999,9	h	R	Preparation avg. [h]
23	146	4	FLOAT	0...0,99999999		R	Preparation count
24	150	4	FLOAT	0...999999,9	h	R	Operating hours total [h]
25	154	4	FLOAT	0...999,9	V	R	Cell voltage [V]
26	158	4	FLOAT	0...999,9	A	R	Electrolysis current [A]
27	162	4	FLOAT	0...999,9	l/h	R	Electrolysis water [l/h]
28	166	4	FLOAT	0...99,9	bar	R	Operating water pressure [bar]
29	170	4	FLOAT	-99,9...99,9	°C	R	Ambient temperature [°C]
30	174	4	FLOAT			R	Unused
31	178	4	FLOAT			R	Unused
32	182	4	FLOAT			R	Unused
33	186	4	FLOAT			R	Unused
34	190	4	FLOAT			R	Unused
35	194	4	FLOAT			R	Unused
36	198	4	FLOAT			R	Unused
37	202.0	1	CHAR			R	Digital IN, EMERGENCY STOP
	202.1					R	Digital IN, ext. Water softener/hardness control
	202.2					R	Digital IN, Release preparation
	202.3					R	Digital IN, Electrolysis water
	202.4					R	Unused
	202.5					R	Digital IN, Vacuum container max
	202.6					R	Digital IN, Vacuum container min
	202.7					R	Digital IN, Cooling water
38	203.0	1	CHAR			R	Digital IN, Chlorine separator
	203.1					R	Digital IN, Air flow monitor
	203.2					R	Digital IN, Fan
	203.3					R	Digital IN, Dosing leak
	203.4					R	Digital IN, System leak
	203.5					R	Digital IN, Storage tank leak
	203.6					R	Digital IN, Storage tank overfilled

Addr.	Byte Address	Length (Byte)	Format	Range	Unit	Status	Description
38	203.7	1	CHAR			R	Digital IN, Storage tank max.
39	204.0	1	CHAR			R	Digital IN, Storage tank min.
	204.1					R	Digital IN, Storage tank empty
	204.2					R	Digital IN, Salt dissolving tank level
	204.3					R	Digital IN, Brine flow
	204.4					R	Digital IN, Rectifier
	204.5					R	Digital IN, Automatic stopcock open
	204.6					R	Digital IN, Automatic stopcock closed
	204.7					R	Digital IN, Chlorine gas alarm
40	205.0	1	CHAR			R	Unused
	205.1					R	Unused
	205.2					R	Unused
	205.3					R	Unused
	205.4					R	Unused
	205.5					R	Unused
	205.6					R	Unused
	205.7					R	Digital IN, Mains monitoring
41	206.0	1	CHAR			R	Digital OUT, Brine pump
	206.1					R	Digital OUT, Alarm horn
	206.2					R	Digital OUT, Alarm light
	206.3					R	Digital OUT, Release metering/decanting
	206.4					R	Digital OUT, Vacuum pump
	206.5					R	Digital OUT, Cooling water
	206.6					R	Digital OUT, Electrolysis water
	206.7					R	Digital OUT, Fan
42	207.0	1	CHAR			R	Digital OUT, Salt dissolving tank
	207.1					R	Digital OUT, Water softener flush
	207.2					R	Digital OUT, Water softener injector
	207.3					R	Digital OUT, Water softener inlet
	207.4					R	Digital OUT, Rectifier
	207.5					R	Digital OUT, Alarm relay 2
	207.6					R	Digital OUT, Alarm relay 1
	207.7					R	Digital OUT, Automatic stopcock
43	208.0	1	CHAR			R	Unused

Addr.	Byte Address	Length (Byte)	Format	Range	Unit	Status	Description
43	208.1	1	CHAR			R	Unused
	208.2					R	Unused
	208.3					R	Unused
	208.4					R	Unused
	208.5					R	Unused
	208.6					R	Unused
	208.7					R	Unused
44	209	1	CHAR			R	Unused
45	210	1	CHAR			R	Unused
46	211	1	CHAR			R	Unused
47	212	1	CHAR			R	Unused
48	213	1	CHAR			R	Unused
49	214.0	1	CHAR			R	Unused
	214.1					R	Unused
	214.2					R	Unused
	214.3					R	Unused
	214.4					R	Unused
	214.5					R	Unused
	214.6					R	Unused
	214.7					R	Unused
50	215.0	1	CHAR			R	User registered via HMI
	215.1					R	User registered via PROFIBUS DP
	215.2					R	User registered via RS485
	215.3					R	Unused
	215.4					R	Unused
	215.5					R	Unused
	215.6					R	Unused
	215.7					R	Unused
51	216	2	UINT			R	Unused
52	218	1	CHAR			R	Unused
53	219	1	CHAR			R	Unused
54	220	1	CHAR			R	Activate test injector via RS485
55	221	1	CHAR			W	Activate test injector via RS485

Addr.	Byte Address	Length (Byte)	Format	Range	Unit	Status	Description
56	222	1	CHAR			R	Activate manual function water softener regeneration via RS485
57	223	1	CHAR			W	Activate manual function water softener regeneration via RS485
58	224	1	CHAR			R	Turn on/off manual function brine filling via RS485
59	225	1	CHAR			W	Turn on/off manual function brine filling via RS485
60	226	1	CHAR			R	Turn on/off manual function cooling water via RS485
61	227	1	CHAR			W	Turn on/off manual function cooling water via RS485
62	228	1	CHAR			R	Turn on/off manual function electrolysis water via RS485
63	229	1	CHAR			W	Turn on/off manual function electrolysis water via RS485
64	230	1	CHAR			R	Start/stop preparation via RS485
65	231	1	CHAR			W	Start/stop preparation via RS485
66	232	1	CHAR			R	Change operating mode via RS485
67	233	1	CHAR			W	Change operating mode via RS485
68	234	2	UINT			R/W	Function [**Internal usage, n.c.**]
69	236	4	CHAR			R/W	Local <> Remote user

5. Operation

5.1 Control and display unit

5.1.1 General

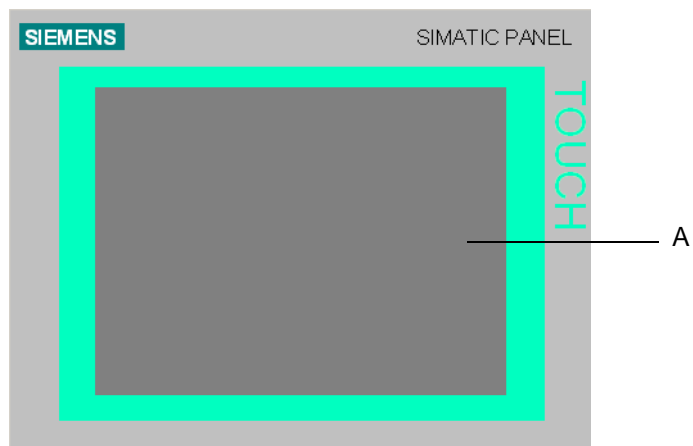

Fig. 1 Siemens SIMATIC Touch Panel

A Display with Touch Screen

The Touch Screen is the standard input device on the control unit. All of the control objects required to control the unit are displayed on the Touch Screen when the control unit is switched on.



Attention!

Damage to the system!

Only touch one control object at a time. You should never touch more than one control object simultaneously, as doing so may trigger operations unintentionally.



Attention!

Damage to the system!

Never use pointed or sharp instruments to operate the Touch Screen or press it hard with a hard object, as this can severely shorten its operational life or cause it to stop working completely. Only touch the Touch Screen with your finger or a Touch stylus.

5.1.2 Main screen

When the chlorine membrane electrolysis system is switched on, the Touch Screen displays the main screen:

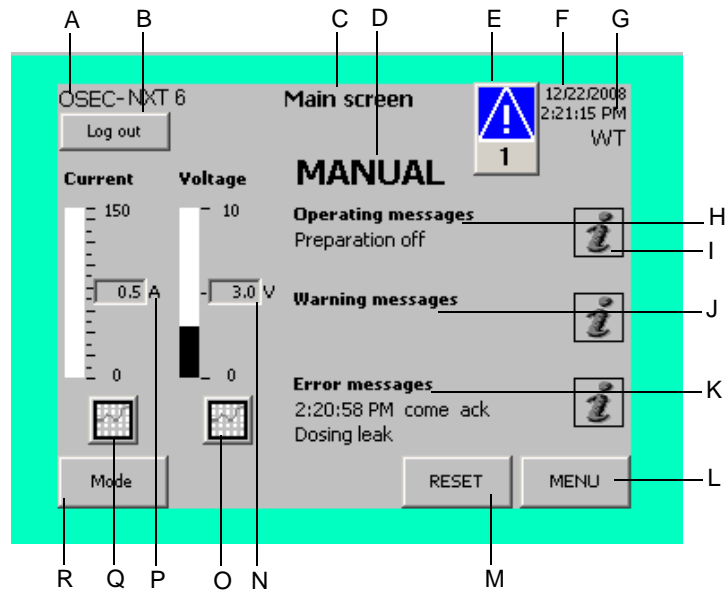

Fig. 2 Main screen showing an error message

- A System type
- B Log in/Log out button (see chapter 5.2.2)
- C Display menu
- D Mode display (Manual or Automatic) (see chapter 5.3)
- E Error display showing the number of faults (see chapter 5.10)
- F Displays the current date
- G Displays the current time
- H Two-line operating messages display (see chapter 5.8)
- I Information button "i", provides information on current messages
- J Two-line warning messages display (see chapter 5.9)
- K Two-line error messages display (see chapter 5.10)
- L Menu selection button
- M Error messages "Reset" button (see chapter 5.10)
- N Current cell voltage display (see chapter 5.11)
- O Cell voltage graph button (see chapter 5.11)
- P Current electrolysis current display (see chapter 5.11)
- Q Electrolysis current graph button (see chapter 5.11)
- R Mode button (Manual or Automatic) (see chapters 5.4 and 5.5)

Buttons

The buttons are used to perform functions and to switch between the menus and displays.



Please Note

Details on the other displays are given in the appropriate chapters.

5.2 Password protection

5.2.1 General

All of the settings and operating parameters can be read by all users, in any user group, without requiring the user to log in. Certain functions are protected, requiring entry of a user name and password, so that they can only be performed by certain groups.

There are three user levels. Only the functions of levels 1 and 2 are accessible to ordinary users.

- Level 1: No login required. For operators and service personnel
- Level 2: Login required. For operators and service personnel
- Level 3: Login required. Only for service personnel

Details on the functions of the different password levels can be found in Description 3.5, Functions.



Please Note

The user name for Level 1 is **WT** and the password is **9040**.

5.2.2 Logging in

Main screen
Log in

MAIN SCREEN

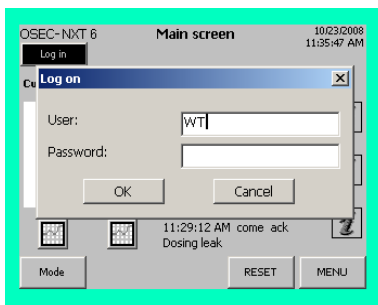

You can log in in any mode. If you have not yet logged in, the "Log in" button flashes, irrespective of which menu you are currently in.

Proceed as follows:

- 1 Press the "Log in" button. The login dialog box will open, with the cursor in the "User" input box.
- 2 Enter the user name for the level you wish to log in to using the keyboard displayed on the screen and then press Return. The cursor will then move to the "Password" box.
- 3 Enter the password for the level you wish to log in to using the keyboard displayed on the screen and then press Return.

Main screen
Log in

MAIN SCREEN

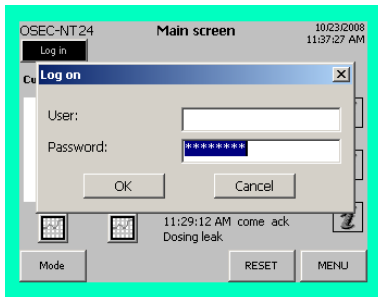

- 4 Press OK to confirm. The display then returns to the previous menu and the "Log in" button changes into a "Log out" button. The required functions are now accessible.



Please Note

Once you have logged in, all of the other functions available to that user level are accessible too. In Level 1 (Operator level) you are automatically logged out of after 60 minutes, and in Level 2 (Service) after five minutes. If a password is required the login dialog box is displayed automatically.

5.3 Automatic mode

Main screen
Mode
Change operating mode? Yes NO
MAIN SCREEN

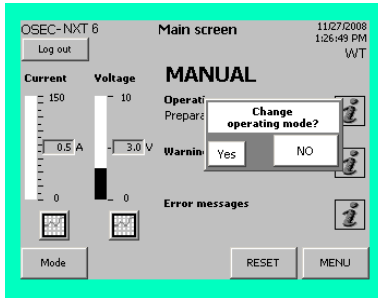

The chlorine membrane electrolysis system is running in automatic mode. Automatic preparation is turned on and off with the "Mode" button (see chapter 5.6 Activating manual preparation and chapter 5.7 Stopping preparation manually for details). The display shows if automatic mode is active.

The chlorine membrane electrolysis system has two operating states in automatic mode.

- Preparation standby
- Preparation active!
 - Preparation run-up
 - Preparation running
 - Preparation run-out

If the system is manual instead of automatic mode there is also another operating state:

- Preparation off

The current operating state is shown on the display under "Operating messages". If additional information is available, it can be displayed by pressing the "i" (Info) button.

Main screen
MAIN SCREEN

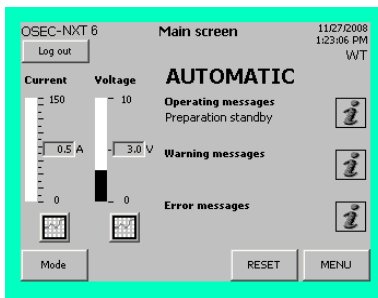

In automatic mode, sodium hypochlorite preparation is controlled via the level switch in the storage tank. The system is initially in the operating state "Preparation standby". Once the "Storage tank min." level is reached, sodium hypochlorite preparation begins.

Main screen
MAIN SCREEN

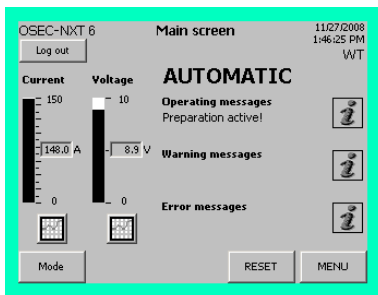

If the chlorine membrane electrolysis system is in the "Preparation active!" operating state, it begins the run-up process ("Preparation run-up"). The "Preparation active!" operating state has three phases:

- The run-up phase
- The preparation phase
- The run-out phase

Main screen

"i" (info) operating messages

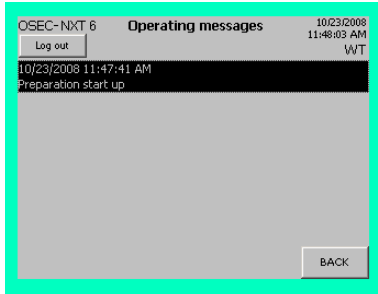
OPERATING MESSAGES
"PREPARATION RUN-UP"

To display details of which phase the system is currently in as well as the date and time, press the "i" (Info) button.

Main screen

"i" (info) operating messages

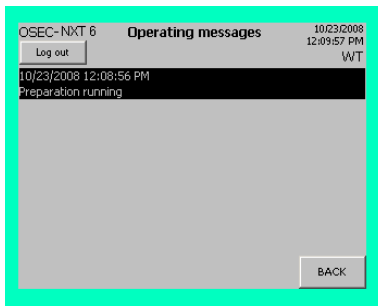
OPERATING MESSAGES
"PREPARATION RUNNING"

Once the run-up process has been completed, the chlorine membrane electrolysis system switches to the preparation phase ("Preparation running") operating state. Sodium hypochlorite preparation stops once the "Storage tank max." fill level is reached.

Main screen

"i" (info) operating messages

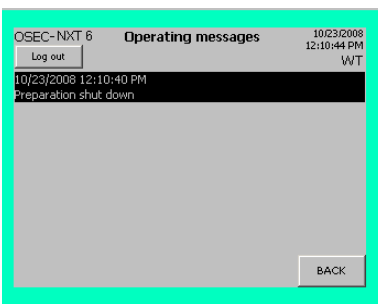
OPERATING MESSAGES
"PREPARATION RUN-OUT"

The chlorine membrane electrolysis system then switches to the run-out phase ("Preparation run-out").

Main screen

MAIN SCREEN

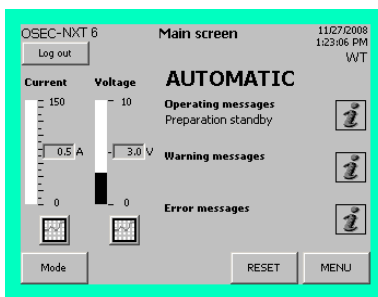

Once the run-out process has been completed, the system reverts to the "Preparation standby" operating state.

5.4 Turning on automatic mode

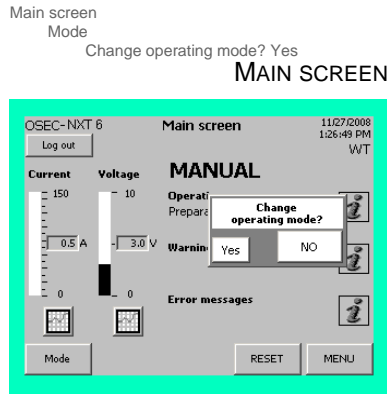

Once run-up has been completed, or once any faults that caused automatic preparation to stop have been corrected, the chlorine membrane electrolysis system enters the "Preparation off" operating state. The system is ready and can be switched to automatic mode.

Proceed as follows:

- 1 Enter the user name and password, if necessary. For details, see chapter 5.2.2 Logging in.
- 2 Press the "Mode" button.

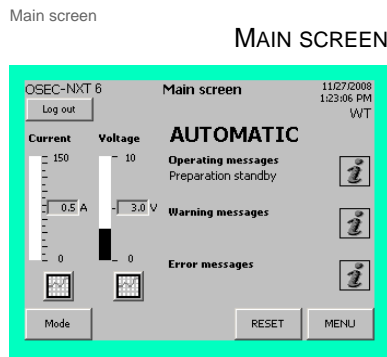

The chlorine membrane electrolysis system is now in automatic preparation mode. If automatic mode is active, this is shown on the display as a text message. For details, see chapter 5.3 Automatic mode and chapter 5.8 Operating messages.

5.5 Turning off automatic mode

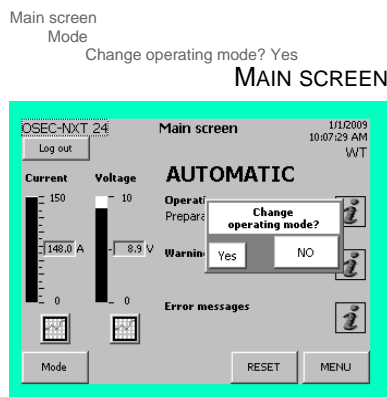

When performing maintenance work or to shut the system down for a short period, switch off automatic mode.

Proceed as follows:

- 1 Enter the user name and password, if necessary. For details, see chapter 5.2.2 Logging in.
- 2 Press the "Mode" button.

Main screen

MAIN SCREEN

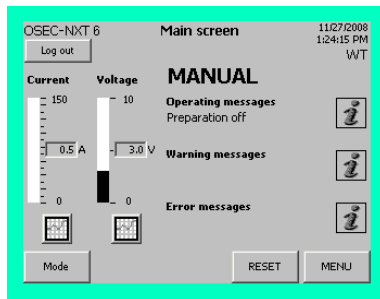

If the chlorine membrane electrolysis system is in the "Preparation active!" operating state, it first goes through the run-out process before then switching automatic mode off.

The system switches to the "Preparation off" operating state. The mode "MANUAL" is displayed as a text message on the display.



Attention!

Damage to the electrolysis cell!

The chlorine membrane electrolysis system can remain like this for a maximum of four weeks, otherwise the electrolysis cell may be damaged.

5.6 Activating preparation manually

Preparation of sodium hypochlorite can also be activated manually when the system is in automatic mode if:

- The chlorine membrane electrolysis system is in the "Preparation standby" operating state.
- The fill level in the storage tank is below "Storage tank max."

Main screen
Start preparation

MAIN SCREEN

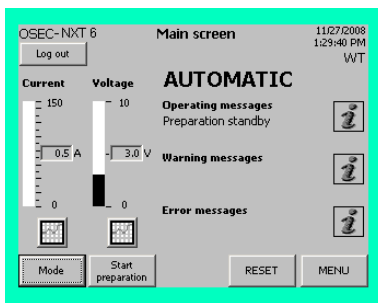

If both of these conditions are met the "Start preparation" button is also displayed on the main screen.

Proceed as follows:

- 1 Press the "Start preparation" button. You will be asked to enter a user name and password. For details, see chapter 5.2.2 Logging in.

The system then switches to the run-up phase of the "Preparation active !" operating state.

Once the run-up phase has been completed, the chlorine membrane electrolysis system switches to the preparation phase and generates sodium hypochlorite until the "Storage tank max." fill level in the storage tank is reached.

Once the "Storage tank max." fill level in the storage tank is reached, the system switches to the run-out phase.

Once the run-out process has been completed, the chlorine membrane electrolysis system switches back to the "Preparation standby" operating state.



Please Note

If a fault occurs at the same time as you attempt to start preparation manually, this is shown on the display. Manual preparation cannot then be started and the "Start preparation" button is hidden.

5.7 Stopping preparation manually

Preparation of sodium hypochlorite can also be stopped manually when the system is in automatic mode if:

- The chlorine membrane electrolysis system is in the "Preparation active!" operating state.
- The fill level in the storage tank is above "Storage tank min.".

Main screen
Stop preparation

MAIN SCREEN

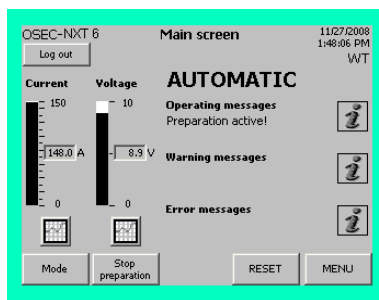

If both of these conditions are met the "Stop preparation" button is also displayed on the main screen.

Proceed as follows:

- 1 Press the "Stop preparation" button. You will be asked to enter a user name and password. For details, see chapter 5.2.2 Logging in.

The system then switches to the run-out phase.

Once the run-out process has been completed, the chlorine membrane electrolysis system switches back to the "Preparation standby" operating state.

Once the "Storage tank min." level in the storage tank is reached, sodium hypochlorite preparation starts again.



Please Note

If a fault occurs at the same time as you attempt to stop preparation manually, this is shown on the display.

5.8 Operating messages

5.8.1 General

There are six different operating messages that can be displayed by the chlorine membrane electrolysis system.

The operating states:

- Preparation off
- Preparation standby
- Preparation active!

Other operating messages include:

- Water softener regenerating
- Preparation ext. locked!



Please Note

These two operating messages are displayed on the screen along with the current operating state. They can be displayed if the operating state is "Preparation standby" or "Preparation off".

- Manual mode active!

If additional information is available about the current operating messages it can be displayed by pressing the "i" (Info) button.

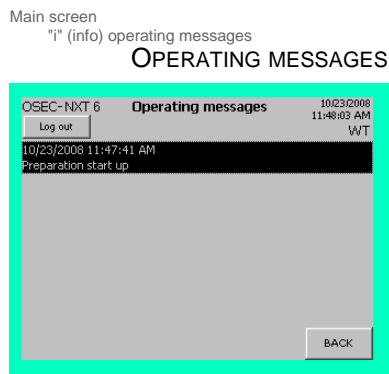

5.8.2 Preparation off

Main screen

MAIN SCREEN

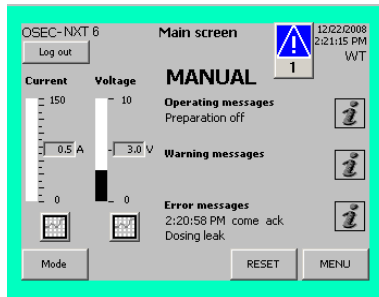

The chlorine membrane electrolysis system is in the "Preparation off" operating state. The system is ready to operate.

- Automatic mode is off
- All of the control system's control functions are active
- The protection potential is switched on
- The fan is running
- If there is a fault, an error message is displayed. (See chapter 5.14 for details on acknowledging and correcting faults)

Main screen

MAIN SCREEN

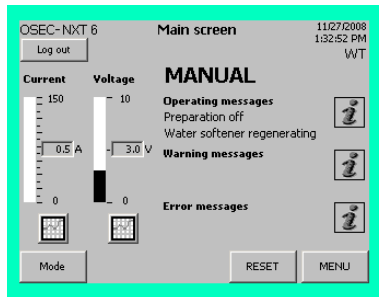

- Automatic regeneration is active. If regeneration is running, this is indicated on the display

5.8.3 Preparation standby

Main screen

MAIN SCREEN

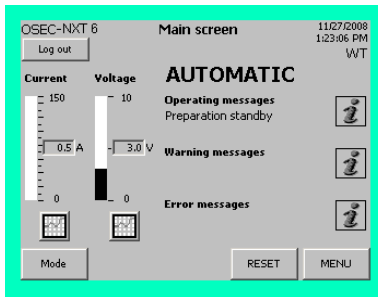

The chlorine membrane electrolysis system is in the "Preparation standby" operating state.

- Automatic mode is active
- All of the control system's control functions are active
- The protection potential is switched on
- The fan is running
- The system is not preparing the product

Main screen

MAIN SCREEN

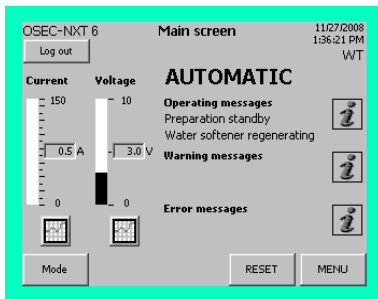

- Automatic regeneration is active. If regeneration is running, this is indicated on the display



Please Note

In "Preparation standby" it is possible to start preparation of sodium hypochlorite manually. The "Start preparation" button is then displayed. See chapter 5.6 Activating preparation manually.

Main screen

Start preparation

MAIN SCREEN

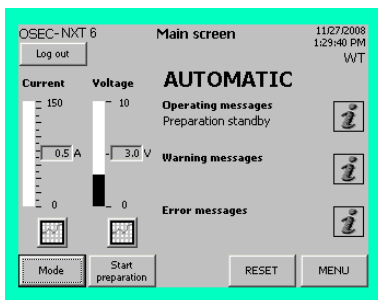



Please Note

Components and hose connections that are mechanically or electrically operated are labeled on the system with abbreviations (e.g. M3). To facilitate their identification, these abbreviations are repeated at relevant points in the operating instructions and on the drawings.

5.8.4 Preparation active!

Main screen

MAIN SCREEN

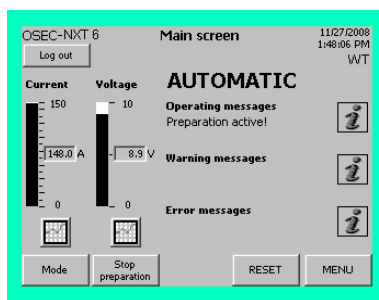

The "Preparation active!" operating state has three phases:

- The run-up phase ("Preparation run-up")
- The preparation phase ("Preparation running")
- The run-out phase ("Preparation run-out")

To display details of which phase the system is currently in as well as the date and time, press the "i" (Info) button.

Main screen

"i" (info) operating messages

OPERATING MESSAGES "PREPARATION RUN-UP"

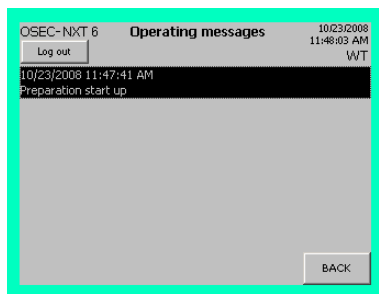

Once the "Storage tank min." fill level in the storage tank is reached, the level switch automatically starts sodium hypochlorite preparation again. The system then switches to the run-up phase of the "Preparation active !" operating state.

If the fluid level limit has not been reached, the brine pump starts. Once the level limit in the chlorine separator is reached, the following process is initiated:

- The brine pump is turned off
- The electrolysis water solenoid valve (E2) is opened
- The inlet water solenoid valve for the softening process (E5) is opened
- The cooling water solenoid valve (E3) is opened
- The electrolysis current is switched on and the voltage increases until the electrolysis power is reached
- Once the electrolysis power is reached the system switches to the preparation phase

Main screen

"i" (info) operating messages

OPERATING MESSAGES
"PREPARATION RUNNING"

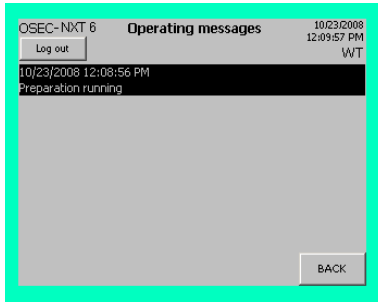

Once electrolysis power is reached, the chlorine membrane electrolysis system switches to the product preparation state and prepares sodium hypochlorite until the "Storage tank max." level is reached in the storage tank.

- The electrolysis water starts flowing
- The cooling water starts flowing
- The brine pump is turned on and off by the level switch in the chlorine separator
- Once the "Storage tank max." fill level is reached, the system switches to the run-out phase

Main screen

"i" (info) operating messages

OPERATING MESSAGES
"PREPARATION SHUT DOWN"

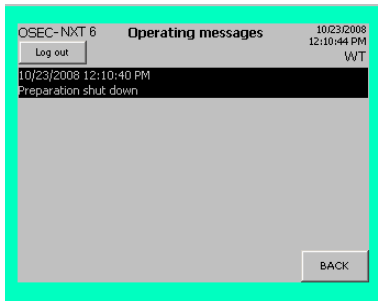

Once the "Storage tank max." fill level in the storage tank is reached, the level switch automatically stops sodium hypochlorite preparation again. The system then switches to the run-out phase.

- The electrolysis current is reduced until the protection potential is reached.

Once the protection potential is reached, the following process is initiated:

- The brine pump is turned off
- The electrolysis water solenoid valve (E2) is closed
- The cooling water solenoid valve (E3) is closed
- The inlet water solenoid valve for the softening process (E5) is closed
- The system switches to the "Preparation standby" operating state

Main screen

MAIN SCREEN

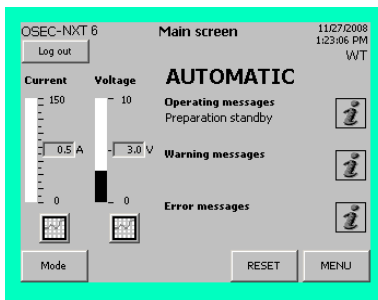

Main screen

MAIN SCREEN

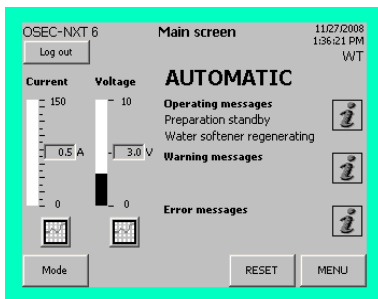

Automatic regeneration is active throughout the preparation process. If regeneration starts, the preparation process is interrupted, the system switches to run-out or stops run-out and remains in the "Preparation standby" state. Regeneration is running. This is indicated on the display. Once regeneration has finished, sodium hypochlorite preparation automatically starts again as soon as the "Storage tank min." fill level in the storage tank is reached.



Please Note

In the "Preparation active!" operating state it is possible to stop preparation of sodium hypochlorite manually. The stop preparation button is displayed for this purpose. See chapter 5.7 Stopping preparation manually for details.

Main screen
Stop preparation

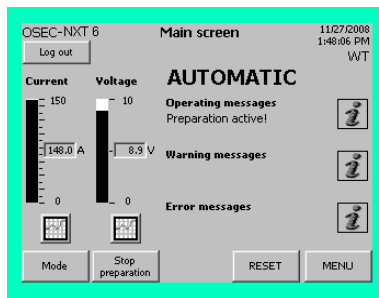
MAIN SCREEN

5.8.5 Water softener regenerating

Main screen

MAIN SCREEN

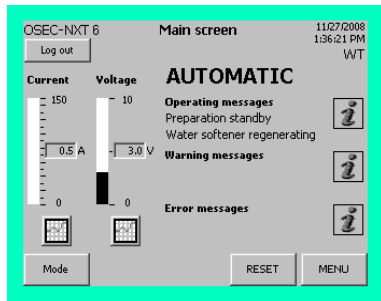

Automatic regeneration is usage-based and depends on the water hardness. The automatic regeneration of the water softener is active in every operating state. If regeneration is running, this is indicated on the display. Press the "i" (Info) button to show the current regeneration phase:

- Water softener reacting
- Water softener adding brine
- Water softener washing

If the chlorine membrane electrolysis system is in the run-up or preparation state, it is interrupted, the system switches to run-out and remains in the "Preparation standby" state. Regeneration is running. This is indicated on the display.

Once regeneration has finished, sodium hypochlorite preparation automatically starts again as soon as the "Storage tank min." fill level in the storage tank is reached.

Regeneration of the water softener can also be started manually via the menu by selecting "Manual functions" - "Water softener".



Please Note

Insufficient salt in the salt dissolving tank leads on to malfunctions on the water softener, consequently resulting in irreparable damage to the chlorine membrane electrolysis system and the electrolysis cells.

Check the fill level of the brine in the salt dissolving tank daily! For details see chapter 5.13.2 Replenishing the salt in the salt dissolving tank.

5.8.6 Preparation ext. locked!

Main screen

MAIN SCREEN

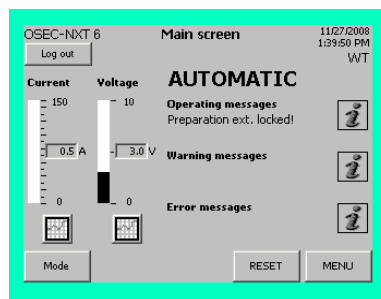

The chlorine membrane electrolysis system control system (available as an option) also provides a digital input for external control of the sodium hypochlorite preparation. This allows the operator to turn off the preparation of sodium hypochlorite from a control room. This is possible in every operating state and is shown on the display.

If the chlorine membrane electrolysis system is in the run-up or preparation state, it is interrupted, the system switches to run-out and remains in the "Preparation standby" state. The system is still in automatic operation. However, the preparation of sodium hypochlorite cannot be triggered.

5.8.7 Manual mode active!

Main screen

MAIN SCREEN

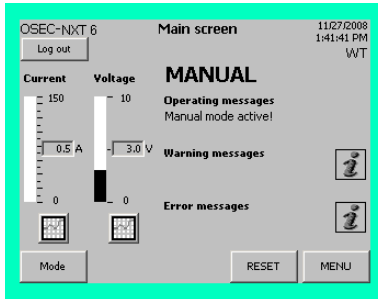

The manual functions are only active in "MANUAL" mode when the system is in the "Preparation off" state. They can be used to enable the required function temporarily. The manual functions are password protected. When they are active, the "i" (Info) button flashes. Three manual functions are displayed:

- MANUAL Cooling water!
- MANUAL Electrolysis water!
- MANUAL Top-up brine!

Main screen

"i" (info) operating messages

OPERATING MESSAGES "MANUAL COOLING WATER"

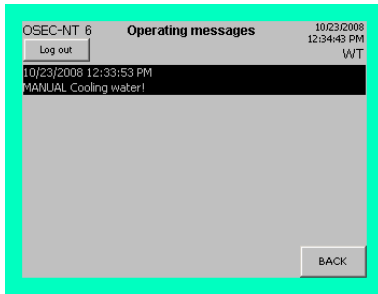

Which of these manual functions is currently active can be displayed in the operating messages menu by pressing the "i" (Info) button.

For further details on the manual functions, see chapter 5.12.6 "Manual functions" menu.

Main screen

"i" (info) operating messages

OPERATING MESSAGES "MANUAL ELECTROLYSIS WA"

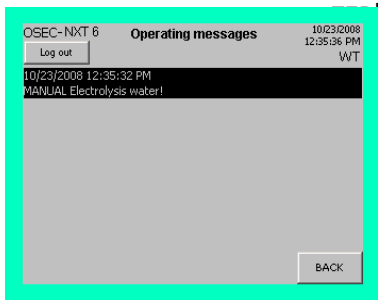

Main screen

"i" (info) operating messages

OPERATING MESSAGES "MANUAL TOP-UP BRINE"

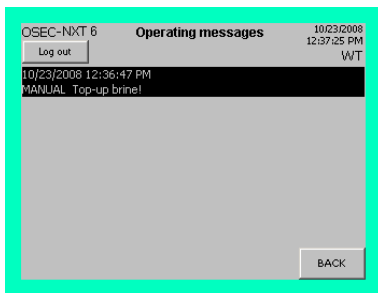

5.9 Warning messages

5.9.1 General

Main screen

MAIN SCREEN

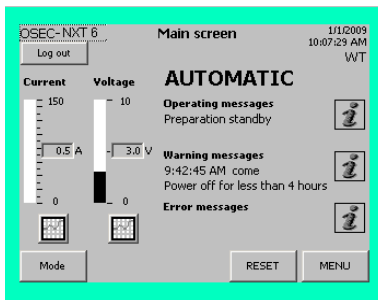

The chlorine membrane electrolysis system is capable of displaying eleven different warning messages. The last warning message reported by the system is displayed as a text message on the main screen, together with the time stamp and the state and the "i" (Info) button flashes:

- Perform monthly maintenance!
- Perform annual maintenance! Service required
- Storage tank empty
- Operating water pressure too low
- Operating water pressure too high
- Check electrolysis water flow rate
- Check water softener brine flow rate
- Power off for less than 4 hours
- Power off for more than 4 hours
- Unstable mains voltage/mains failure
- Ambient temperature too high

The chlorine membrane electrolysis system stays in the current operating state. The current automatic process is not interrupted. The text message and the flashing "i" (Info) button disappear once the cause of the fault has been corrected.

Main screen

"i" (info) warning messages

WARNING MESSAGES

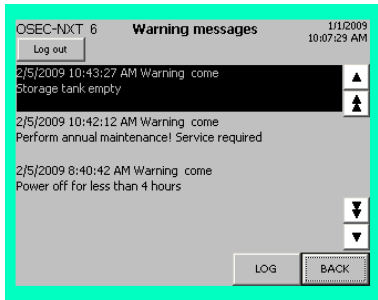

The "i" (Info) button allows you to view the current warning messages that have been displayed by the system, including the date, time and status details ("come"), at any time.

The arrow keys are used to navigate around the display.

Press the "LOG" button to open the "Warning message log".

Main screen

Menu selection

Diagnostics

Warning message log

WARNING MESSAGE LOG

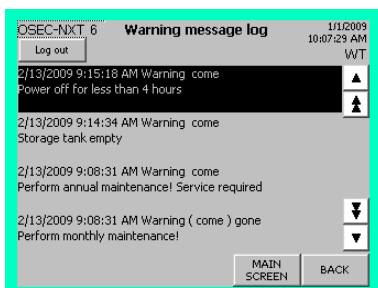

All of the warnings are stored in the "Warning message log" together with the date, time and status details ("coming" and "going") and can be viewed at any time. See chapter 5.12.3 Diagnostics, warning message log.

5.9.2 Perform monthly maintenance!

Main screen

MAIN SCREEN

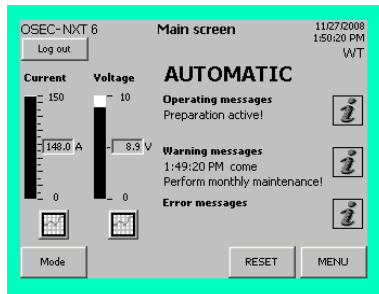

The warning "Perform monthly maintenance!" is displayed once a month. This warning message can be displayed in every operating state. The chlorine membrane electrolysis system remains operational. The warning message is turned off again once you have confirmed that monthly maintenance has been carried out by pressing the "Maintenance" button on the main "Service" menu, see chapter 5.12.4 "Service menu". See chapter 5.13 Maintenance by the operator for further details on carrying out monthly maintenance.

5.9.3 Perform annual maintenance! Service required

Main screen

MAIN SCREEN

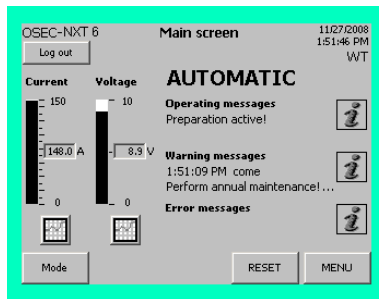

Once a year, annual maintenance must be carried out by Evoqua service personnel or by personnel trained and authorized by Evoqua for maintenance work. This is indicated on the display. This warning message will be displayed for the first time after six months, and then every twelve months thereafter. This warning message can be displayed in any operating mode. The chlorine membrane electrolysis system remains operational. The warning message is turned off again once you have confirmed that annual maintenance has been carried out by pressing the "Maintenance" button on the main "Service" menu, see chapter 5.12.4 "Service menu". See chapter 6. "Maintenance by a service technician" for further details on carrying out annual maintenance.

5.9.4 Storage tank empty

Main screen

MAIN SCREEN

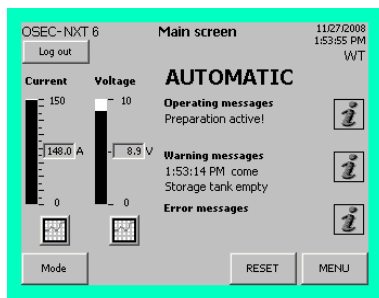

Once the fill level in the storage tank reaches the "Storage tank empty" level, the warning message "Storage tank empty" is displayed.

This may be because of:

- Automatic preparation is switched off. But sodium hypochlorite is being drawn by the system nevertheless,
- The unit is operating in automatic mode and more sodium hypochlorite is being drawn by the system than the unit can produce, or

Proceed as follows:

- 1 Check the display to see whether "Automatic" mode is on.
- 2 Perform a visual inspection of the chlorine membrane electrolysis system and the sodium hypochlorite tank to check for leaks and damage.

5.9.5 Operating water pressure too low

Main screen

MAIN SCREEN

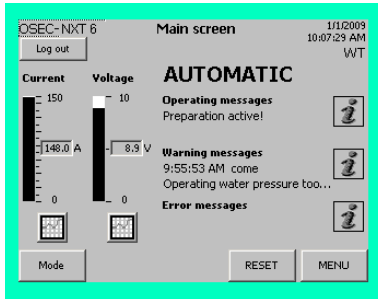

If the actual operating water pressure drops below the setpoint (see the information label on the chlorine membrane electrolysis system) the warning "Operating water pressure too low" is displayed.

This may be because of:

- Operating water pressure setting incorrect.
- Local admission pressure too low or zero.
- Operating water pressure reducing valve filter (M3) contaminated
- Operating water pressure reducing valve filter (M3) faulty

Proceed as follows:

- 1 Check operating water pressure and, if necessary, adjust it to match the specifications displayed on the system by the operating water pressure reducing valve (M3).
- 2 Check the local admission pressure and adjust if necessary.
- 3 Clean the operating water pressure reducing valve filter (M3) For further details see chapter 5.13.6 "Checking and cleaning the filter".

5.9.6 Operating water pressure too high

Main screen

MAIN SCREEN

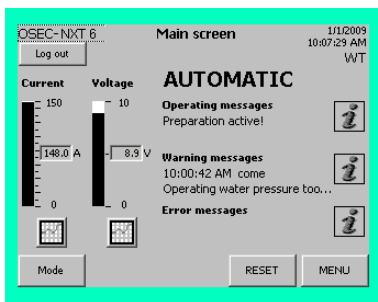

If the actual operating water pressure exceeds the setpoint (see the information label on the chlorine membrane electrolysis system) the warning "Operating water pressure too high" is displayed.

This may be because of:

- Operating water pressure setting incorrect.
- Local admission pressure too high.
- Operating water pressure reducing valve filter (M3) contaminated
- Operating water pressure reducing valve filter (M3) faulty

Proceed as follows:

- 1 Check operating water pressure and, if necessary, adjust it to match the specifications displayed on the system by the operating water pressure reducing valve (M3).
- 2 Check the local admission pressure and adjust if necessary.
- 3 Clean the operating water pressure reducing valve filter (M3) For further details see chapter 5.13.6 "Checking and cleaning the filter".

5.9.7 Checking electrolysis water flow rate

Main screen

MAIN SCREEN

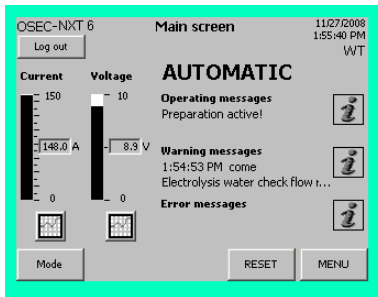

If the actual electrolysis water flow rate differs from the setpoint (see the signs on the chlorine membrane electrolysis system), the warning "Electrolysis water check flow rate" is displayed.

This may be because of:

- Flow rate setting incorrect.
- Operating water pressure setting incorrect
- Local admission pressure incorrect
- Operating water pressure reducing valve filter (M3) contaminated

Proceed as follows:

- 1 Check the electrolysis water flow rate and adjust it to match the specifications displayed on the system by the electrolysis water flow meter (M7).
- 2 Check operating water pressure and, if necessary, adjust it to match the specifications displayed on the system by the operating water pressure reducing valve (M3).
- 3 Check the local admission pressure and adjust if necessary.
- 4 Clean the operating water pressure reducing valve filter (M3) For further details see chapter 5.13.6 "Checking and cleaning the filter".

5.9.8 Checking water softener brine flow rate

Main screen

MAIN SCREEN

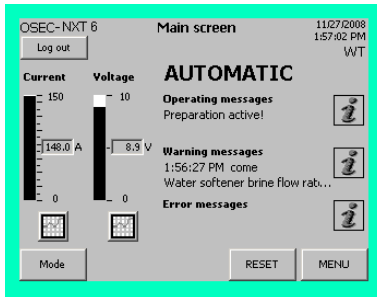

If the actual brine flow rate in the water softener differs from the setpoint the warning "Check water softener brine flow rate" is displayed.

This may be because of:

- Operating water pressure too low
- No brine/salt dissolving tank empty
- Brine inlet faulty
- Water softener drain dirty or back-pressure
- Injector faulty

Proceed as follows:

- 1 Check operating water pressure and, if necessary, adjust it to match the specifications displayed on the system by the operating water pressure reducing valve (M3).
- 2 Check the fill level of the brine in the salt dissolving tank.
- 3 Perform a visual inspection of the brine supply pipes for leaks.
- 4 Check water softener drain.
- 5 Check the injector.

5.9.9 Power off for less than 4 hours

Main screen

MAIN SCREEN

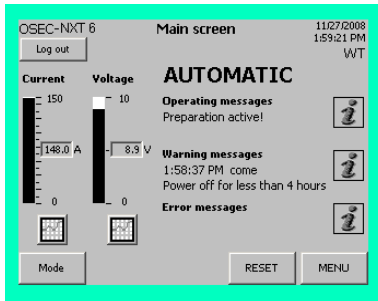

If there is a short power failure (< 4 h) the warning "Power off for less than 4 hours" is displayed for 10 seconds.

Once the power is restored the chlorine membrane electrolysis system can continue operating normally in automatic mode.

You can check how often this warning message has been displayed, together with details of the date, time stamp and state, at any time by pressing the "i" (Info) button.

5.9.10 Power off for more than 4 hours

Main screen

MAIN SCREEN

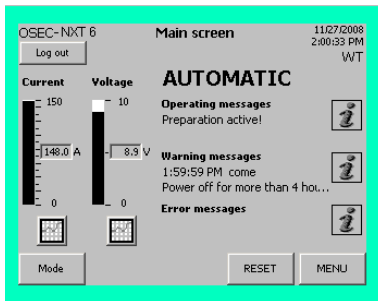

If there is a power failure lasting more than 4 hours, the warning "Power off for more than 4 hours" is displayed for 10 seconds.

Once the power supply is restored after a power failure lasting more than four hours, deactivate automatic mode immediately by pressing the "Mode" button.



Attention!

If there is a power failure lasting more than four hours, the electrolysis cells may be permanently damaged due to the loss of the protection potential. If this occurs, please contact Evoqua customer service immediately.



Please Note

If you know that the power supply is going to be interrupted for four hours or more, the chlorine membrane electrolysis system must be shut down by trained and authorized personnel or by Evoqua service personnel.

5.9.11 Unstable mains voltage/mains failure

Main screen

MAIN SCREEN

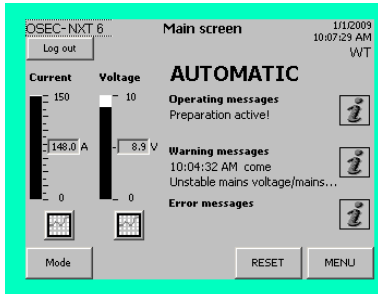

If the power supply fails (see chapter Installation, 4.5.1 Checking the power supply), the warning "Unstable mains voltage/mains failure" is displayed.

This may be because of:

- The mains voltage is outside the tolerances (over/undervoltage)
- Phase failure/neutral conductor failure
- Phase sequence incorrect

Proceed as follows:

- 1 Have the power supply required connected by an authorized and qualified electrical technician.

5.9.12 Ambient temperature too high

Main screen

MAIN SCREEN

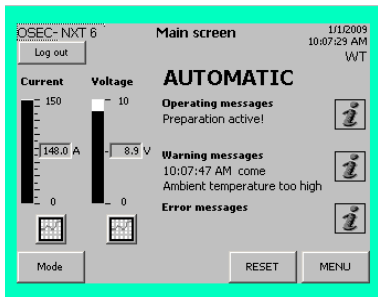

If the actual ambient temperature exceeds the set limit the warning "Ambient temperature too high" is displayed.

This may be because of:

- No fresh air supply
- External source of heat

Proceed as follows:

- 1 Ensure there is a supply of fresh air.
- 2 Measure the ambient temperature and cool the air in the room if necessary.





Please Note

For further details see chapter Installation, 4.3.1 Installation room.

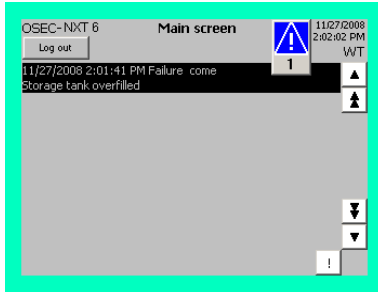
5.10 Error messages



If the system develops a fault, a corresponding error message is displayed, irrespective of the current operating state or what else is currently being displayed by the system. Every error message has to be acknowledged individually by pressing the  button. Once the last error message has been acknowledged the display returns to the last menu that was displayed and the  symbol is displayed.

Main screen

MAIN SCREEN

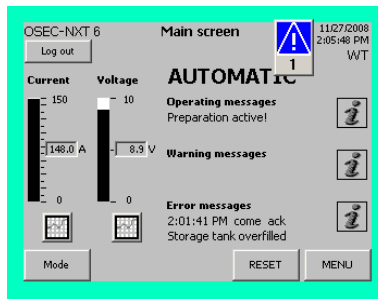

The last error message reported by the system is displayed as a text message on the main screen, together with the time stamp and the state and the "i" (Info) button flashes.

Depending on the nature of the fault, the chlorine membrane electrolysis system then switches to one of the following states:

- "Preparation off"
Automatic mode is off
- "Preparation standby"
Automatic mode is on

or

- it remains in the current operating state. The current automatic process is not interrupted.

The text message, the symbol  and the flashing "i" (Info) button all cease to be displayed once the fault has been cleared and the "RESET" button has been pressed.

Main screen
 "i" (info) Error messages
ERROR MESSAGES

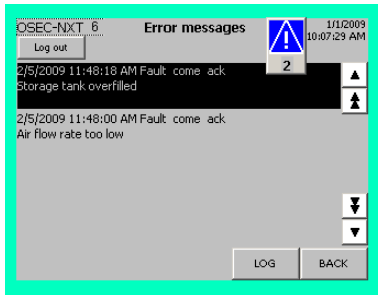

The "i" (Info) button allows you to view the error messages that have been displayed by the system, including the date, time and status details ("come", "ack" and "gone"), at any time.

The arrow keys are used to navigate around the display.

Press the "LOG" button to open the "Error message log".

Main screen
 MENU
 Menu selection
 Diagnostics
 Error message log
ERROR MESSAGE LOG

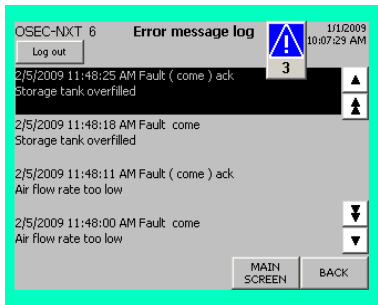

All faults are also stored in the error message log and can be viewed there at any time. See chapter 5.12.3 "Error message log" for details.



Please Note

Chapter 5.14 Faults lists all of the error messages individually, along with their effects, possible causes and troubleshooting tips.

5.11 Reading the cell voltage and electrolysis current

Main screen

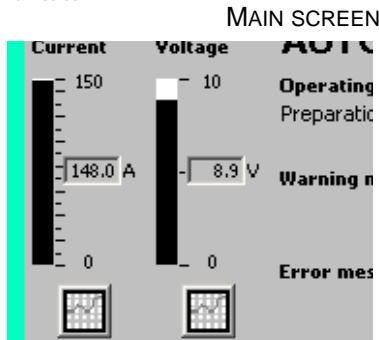

The current cell voltage and electrolysis current can be seen on the main screen at all times. They are displayed both as a bar and as a number to the right of the bar.

If the system is in the "Preparation off" or "Preparation standby" state, the protection potential is displayed. The protection potential for the OSEC-NXT 6 is approx. 3 Volt. Set the current to the value indicated, with a maximum of approx. 0.5 A.

Main screen

Current button

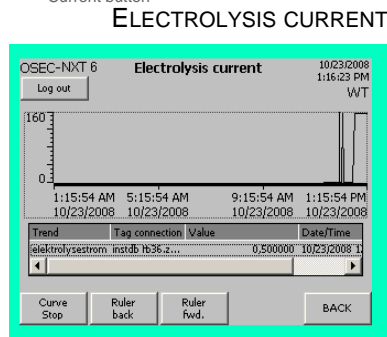

The two buttons below the bar can be used to display the course of the electrolysis current and the cell voltage over the past 12 hours for diagnostic purposes.

The ruler can be used to select any specific time in this period. The value at that point in time is then displayed as a text message, together with its time stamp. To move the ruler, press the "Ruler fwd." and "Ruler back" buttons or drag the ruler in either direction.

Main screen

Voltage button

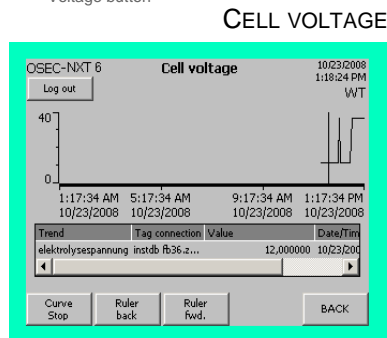

5.12 Menus

5.12.1 Menu selection

Main screen
MENU

MAIN SCREEN

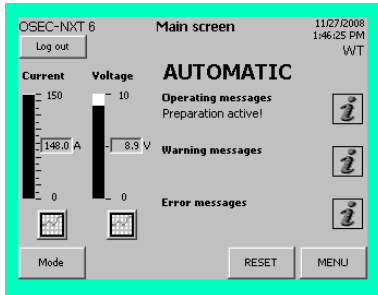

Pressing the „MENU“ button on the basic display opens the „Menu selection“ screen.

Main screen
MENU

MENU SELECTION

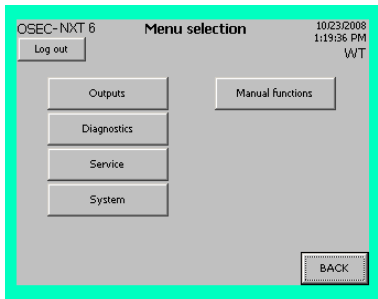

You can select from a total of 5 menus:

- Outputs
- Diagnostics
- Service
- System
- Manual functions

All of the menus are accessible to all user groups to display the operating parameters and settings and do not require a user name or password, irrespective of the current operating state of the chlorine membrane electrolysis system.



Please Note

The "Manual functions" button is only displayed on the "Menu selection" screen when the system is in "MANUAL" mode. It is not displayed when the system is in Automatic mode.

5.12.2 "Outputs" menu

Main screen
MENU
Menu selection
Outputs

OUTPUTS

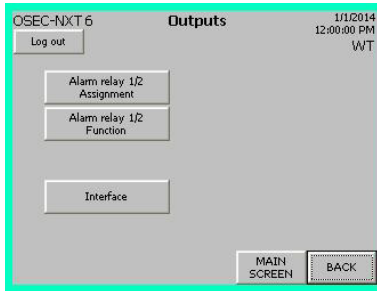

The control system provides two potential-free alarm relays for operating messages, warning messages or error messages as well as interfaces to the bus systems Evoqua RS485 bus and Profibus DP.

In the "Outputs" menu you can assign various messages to the alarm relay and the interfaces to certain addresses.

The "Outputs" menu has the following submenus:

- Alarm relay 1/2 assignment
- Alarm relay 1/2 function
- Interface

The "Alarm relay 1/2 Assignment" submenu consists of several screens. Press the "FWD" button to move to the next screen, and "BACK" to go back to the previous screen.

Main screen
MENU
Menu selection
Outputs

Alarm relay 1/2 Assignment RELAY ASSIGNMENT

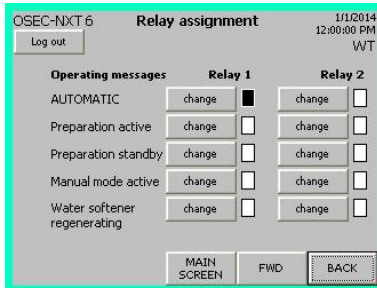

Proceed as follows:

- 1 Move to the "Relay assignment" screen.
- 2 If you wish to assign a message, select the required message from the sources mentioned and press the "change" button for relay 1. You will be asked to enter a user name and password. For details, see chapter 5.2.2 Logging in.

The corresponding status indicator changes from white to black.

- 3 Same procedure for relay 2

Main screen
MENU
Menu selection
Outputs

Alarm relay 1/2 Assignment FWD RELAY ASSIGNMENT

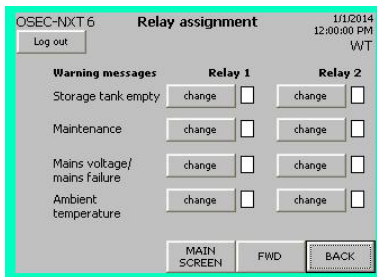

- Selection warning messages

Main screen
 MENU
 Menu selection
 Outputs
 Alarm relay 1/2 Assignment
 FWD
RELAY ASSIGNMENT

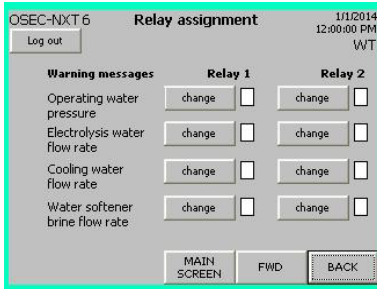

- Selection warning messages

Main screen
 MENU
 Menu selection
 Outputs
 Alarm relay 1/2 Assignment
 FWD
RELAY ASSIGNMENT

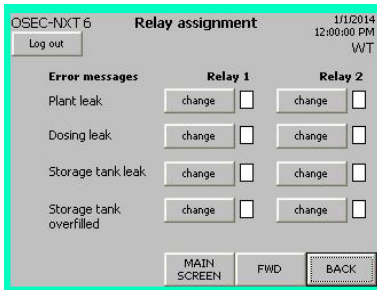

- Selection error messages

Main screen
 MENU
 Menu selection
 Outputs
 Alarm relay 1/2 Assignment
 FWD
RELAY ASSIGNMENT

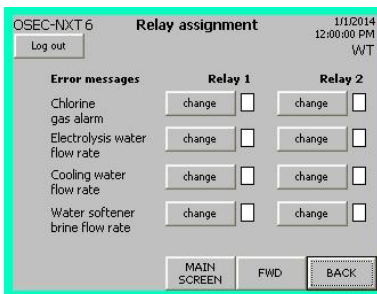

- Selection error messages

Main screen
MENU
Menu selection
Outputs
Alarm relay 1/2 Assignment
FWD
RELAY ASSIGNMENT

OSEC-NXT 6 **Relay assignment** 1/1/2014 12:00:00 PM W/T
Log out

Error messages	Relay 1	Relay 2
Rectifier not ready	change <input type="checkbox"/>	change <input type="checkbox"/>
Fan failure	change <input type="checkbox"/>	change <input type="checkbox"/>
Air flow rate too low	change <input type="checkbox"/>	change <input type="checkbox"/>
Check air flow monitor	change <input type="checkbox"/>	change <input type="checkbox"/>

MAIN SCREEN FWD BACK

- Selection error messages

Main screen
MENU
Menu selection
Outputs
Alarm relay 1/2 Assignment
FWD
RELAY ASSIGNMENT

OSEC-NXT 6 **Relay assignment** 1/1/2014 12:00:00 PM W/T
Log out

Error messages	Relay 1	Relay 2
Cell voltage too high	change <input type="checkbox"/>	change <input type="checkbox"/>
Electrolysis current too low	change <input type="checkbox"/>	change <input type="checkbox"/>
Brine pump wait time exceeded	change <input type="checkbox"/>	change <input type="checkbox"/>
Brine pump run time exceeded	change <input type="checkbox"/>	change <input type="checkbox"/>

MAIN SCREEN FWD BACK

- Selection error messages

Main screen
MENU
Menu selection
Outputs
Alarm relay 1/2 Assignment
FWD
RELAY ASSIGNMENT

OSEC-NXT 6 **Relay assignment** 1/1/2014 12:00:00 PM W/T
Log out

Error messages	Relay 1	Relay 2
Automatic stopcock will not open	change <input type="checkbox"/>	change <input type="checkbox"/>
Automatic stopcock will not close	change <input type="checkbox"/>	change <input type="checkbox"/>
Siphon device time exceeded	change <input type="checkbox"/>	change <input type="checkbox"/>
Siphon device plausibility	change <input type="checkbox"/>	change <input type="checkbox"/>

MAIN SCREEN FWD BACK

- Selection error messages

Main screen
 MENU
 Menu selection
 Outputs
 Alarm relay 1/2 Assignment
 FWD
RELAY ASSIGNMENT

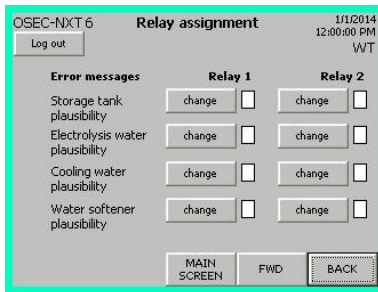

- Selection error messages

Main screen
 MENU
 Menu selection
 Outputs
 Alarm relay 1/2 Assignment
 FWD
RELAY ASSIGNMENT

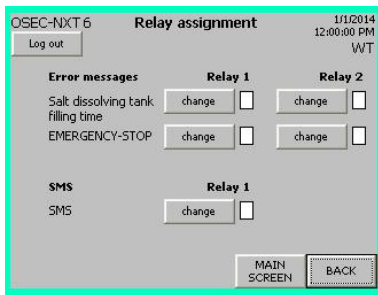

- Selection error messages
- Selection SMS



Please Note

The "EMERGENCY STOP" function causes the chlorine membrane electrolysis system to stop immediately in the event of a hazardous situation.



Please Note

The SMS option is optional and requires the SMS and Teleservice kit.

Main screen
MENU
Menu selection
Outputs
Alarm relay 1/2 function
RELAY FUNCTION

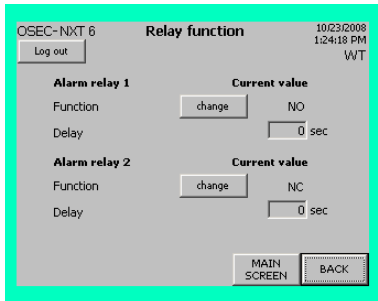

Both of the alarm relays, 1 and 2, require an NC (normally closed) or NO (normally open) switching function. If a time delay is needed before the switching function is triggered, you can also specify a delay of between 0 and 3600 seconds.

Proceed as follows:

- 1 Switch to the "Relay function" screen. The default factory setting for Alarm relay 1 is the NO switching function, and NC for Alarm relay 2. The default delay time for both alarm relays is 0 seconds.
- 2 The default settings can be changed if necessary. You will be asked to enter a user name and password. For details, see chapter 5.2.2 Logging in.

Main screen
MENU
Menu selection
Outputs
Interface
INTERFACE

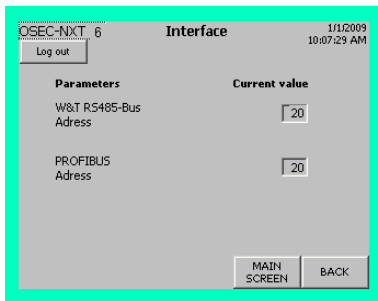

Proceed as follows:

- 1 Switch to the "Interface" screen. The factory setting for the bus addresses is 20.
- 2 The default settings can be changed if necessary. You will be asked to enter a user name and password. For details, see chapter 5.2.2 "Logging in".

5.12.3 "Diagnostics" menu

Main screen
MENU
Menu selection
Diagnostics

DIAGNOSTICS

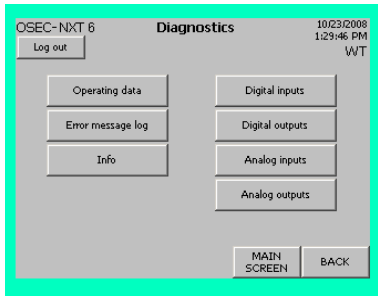

In the "Diagnostics" menu, all of the operating parameters and settings can be viewed without needing to enter a user name or password.

The "Diagnostics" menu has the following submenus:

- Operating data
- Warning message log
- Error message log
- Info
- Digital inputs
- Digital outputs
- Analog inputs
- Analog outputs

Main screen
MENU
Menu selection
Diagnostics
Operating data

OPERATING VALUES

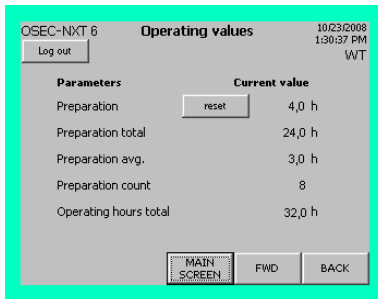

The "Operating data" submenu consists of several screens. Press the "FWD" button to move to the next screen, and "BACK" to go back to the previous screen.

The first screen shows the current number of hours the system has been operating and preparing sodium hypochlorite for (the system uptime):

- Preparation
The so called "Day uptime counter". Gives the number of hours the system has actually been preparing sodium hypochlorite since it was last reset. To reset the system you will need to enter a user name and password. For details, see chapter 5.2.2 Logging in.
- Preparation total
Gives the number of hours the system has actually been preparing sodium hypochlorite since it was last switched on.
- Preparation avg.
Gives the average length of a preparation count (in the "Preparation active!" operating state).
- Preparation count
Gives the number of preparation counts (in the "Preparation active!" state) since the system was last switched on.
- Operating hours total
Gives the total number of hours the system has been on since it was last switched on.



Please Note

The preparation and total operating hours should be entered in the operating journal.

Main screen

MENU

Menu selection

Diagnostics

Operating data

"FWD"

OPERATING VALUES

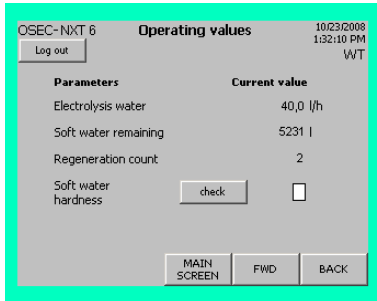

- **Electrolysis water**
Current electrolysis water flow rate. The specific flow rate that is required is system-specific. See the information signs on the chlorine membrane electrolysis system.
- **Soft water remaining**
Shows the remaining amount of soft water available in the system.
- **Regeneration count**
Gives the number of regeneration counts that have been completed (how often the status message "Water softener regenerating" has been displayed) since the system was switched on.
- **Soft water hardness**
As part of the weekly maintenance, the hardness of the electrolysis water needs to be checked. Pressing the "check" button opens the inlet water solenoid valve for the softening process (E5) for 300 s. You can then take a sample of soft water to check using the water hardness test kit. For details on this, see chapter 5.13.3 Measuring hardness of the soft water.
While the valve is open the status indicator is black.

You will be asked to enter a user name and password. For details, see chapter 5.2.2 Logging in.

Main screen

MENU

Menu selection

Diagnostics

Operating data

"FWD"

OPERATING DATA

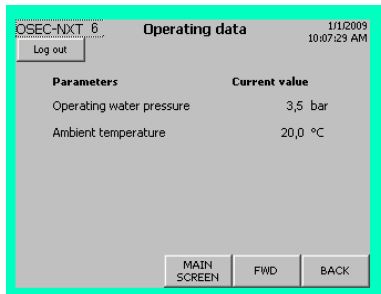

- Current operating water pressure as measured
- Current ambient temperature as measured

Main screen

MENU

Menu selection

Diagnostics

Operating data

"FWD"

OPERATING VALUES

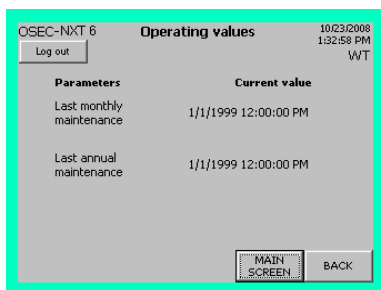

- Date of last monthly maintenance
- Date of last annual maintenance

Main screen
 MENU
 Menu selection
 Diagnostics
 Warning message log
WARNING MESSAGE LOG

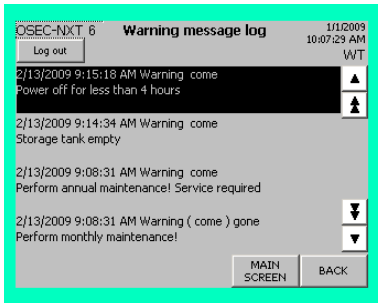

All of the warnings are stored in the "Warning message log" and can be viewed at any time, irrespective of the current operating state.

The display is structured as follows:

- Date of the warning message
- Time of the warning message
- Status of the warning message There are two different statuses:
 - come
 - gone
- Warning message text

The arrow keys are used to navigate around the display. Press "BACK" or "MAIN SCREEN" to exit the warning message log again.

Main screen
 MENU
 Menu selection
 Diagnostics
 Error message log
ERROR MESSAGE LOG

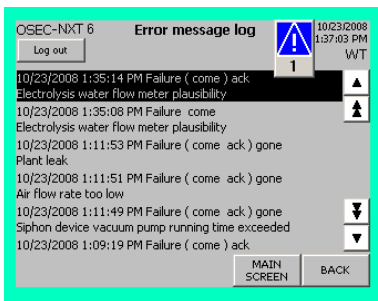

All of the errors are stored in the "Error message log" and can be viewed at any time, irrespective of the current operating state.

The display is structured as follows:

- Date of the error message
- Time of the error message
- Status of the error message There are three different statuses:
 - come
 - ack
 - gone
- Error message text

The arrow keys are used to navigate around the display. Press "BACK" or "MAIN SCREEN" to exit the error message log again.

Main screen
MENU
Menu selection
Diagnostics
Info

INFO

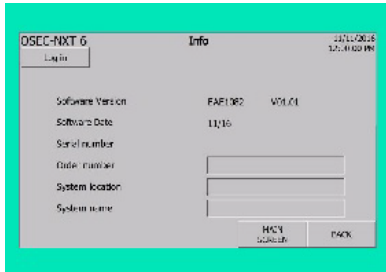

In the "Info" menu you can view the software version, its date and the chlorine membrane electrolysis system's serial number.

The operator can also enter other information about the chlorine membrane electrolysis system here. You will be asked to enter a user name and password. For details, see chapter 5.2.2 Logging in.

Proceed as follows:

- 1 Touch the input box you want to access and keyboard will be displayed.
- 2 Enter the number or name and confirm by pressing Enter.

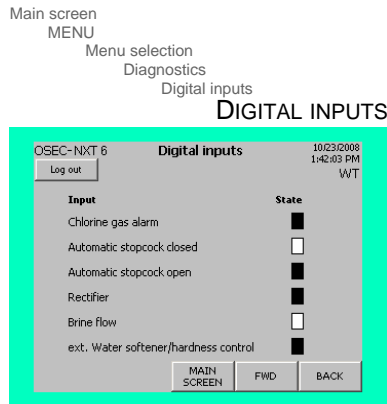

In the "Digital inputs" menu you can view the current status of the digital inputs for diagnostic purposes.

A white signal status box means that the potential on the digital input is zero, a black signal status box means that the potential on the digital input is not zero.

The "Digital inputs" submenu consists of several screens. Press the "FWD" button to move to the next screen, and "BACK" to go back to the previous screen.

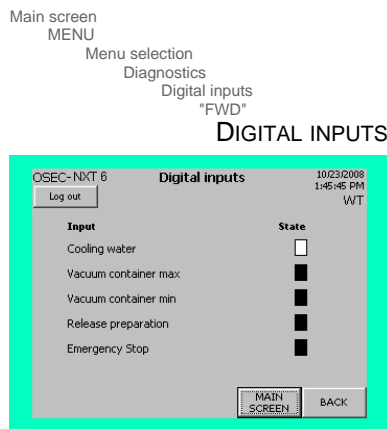
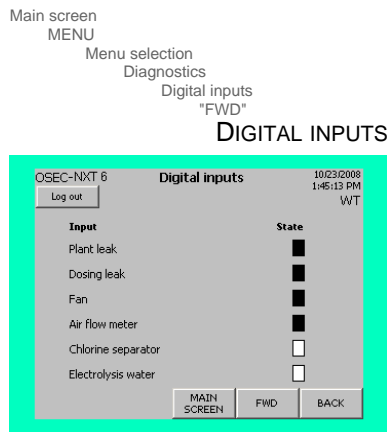
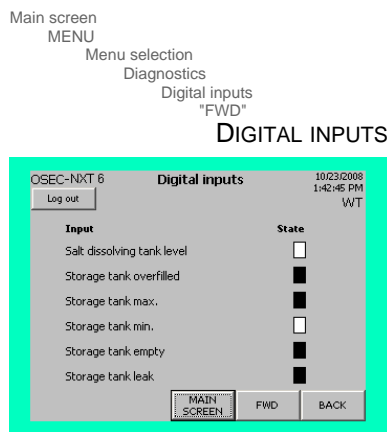

Main screen

MENU

Menu selection

Diagnostics

Digital outputs

DIGITAL OUTPUTS

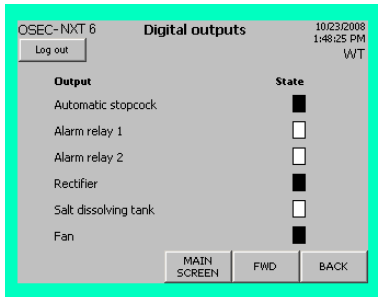

In the "Digital outputs" menu you can view the current status of the digital outputs for diagnostic purposes.

A white signal status box means that the digital output is set to zero, a black signal status box means that the potential on the digital output is set to one.

The "Digital outputs" submenu consists of several screens. Press the "FWD" button to move to the next screen, and "BACK" to go back to the previous screen.

Main screen

MENU

Menu selection

Diagnostics

Digital outputs

"FWD"

DIGITAL OUTPUTS

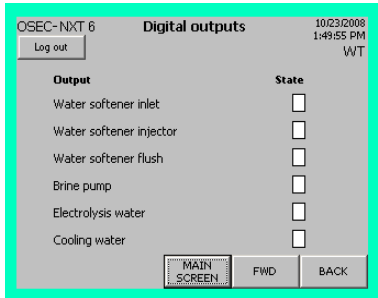

Main screen

MENU

Menu selection

Diagnostics

Digital outputs

"FWD"

DIGITAL OUTPUTS

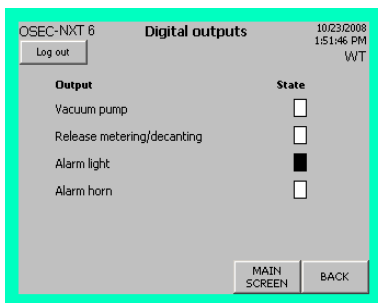

Main screen
 MENU
 Menu selection
 Diagnostics
 Analog inputs

ANALOG INPUTS

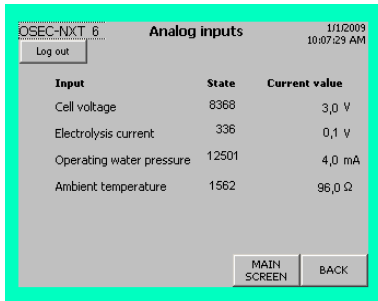

In the "Analog inputs" menu service personnel can view the current values and states of the analog inputs for the cell voltage and the electrolysis current, the operating water pressure and the ambient temperature for diagnostic purposes.

The current cell voltage and electrolysis current values are always between 0 - 10 volts, and between 4 - 20 mA for the operating water pressure. The corresponding processing state displayed is between 0 and 27648.

The current value for the ambient temperature is always between 96 and 131 Ohm. The corresponding digital state is between -328 and 1562.

Main screen
 MENU
 Menu selection
 Diagnostics
 Analog outputs

ANALOG OUTPUTS

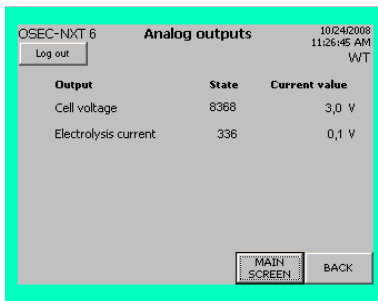

In the "Analog outputs" menu service personnel can view the current values and states of the analog outputs for the cell voltage and the electrolysis current for diagnostic purposes.

The current cell voltage and electrolysis current values are always between 0 - 10 volts. The corresponding digital state is between 0 and 32767.

5.12.4 "Service" menu

Main screen
MENU
Menu selection
Service

SERVICE

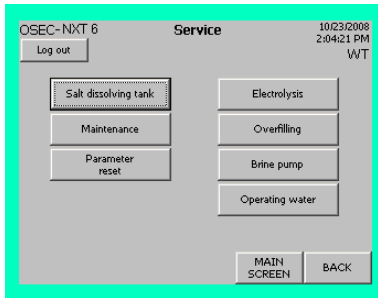

The "Service" menu is primarily intended for use by service personnel (password level 3). All of the settings and operating parameters can, however, be read by all users, in any user group, without requiring the user to log in. From password level 2, the user can enter or change certain system settings.

The "Service" menu has the following submenus:

- Salt dissolving tank
- Maintenance
- Parameter reset
- Electrolysis
- Overfilling
- Brine pump
- Operating water

Main screen
MENU
Menu selection
Service
Salt dissolving tank

SALT DISSOLVING TANK

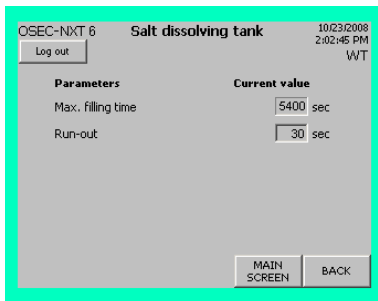

The "Salt dissolving tank" menu is used to enter limits for the max. filling time and run-out time for the salt dissolving tank. If the values entered here are exceeded an error message is generated.

You will be asked to enter a user name and password. For details, see chapter 5.2.2 Logging in.

Main screen
MENU
Menu selection
Service
Maintenance

SERVICE

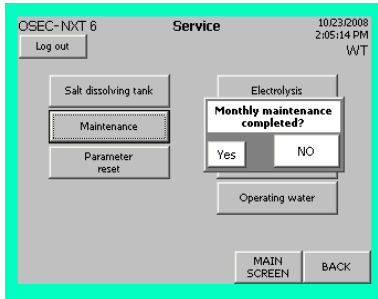

Regular service of the chlorine membrane electrolysis system is part of the liability for defects. There are certain tasks that the operator is required to perform on a daily, weekly or monthly basis. Once a year, annual maintenance must be carried out by Evoqua service personnel or by personnel trained and authorized by Evoqua for maintenance work. When monthly or annual maintenance is due a warning message is displayed on the main screen.

To confirm that maintenance has been carried out, press the "Maintenance" button. You will be asked to enter a user name and password. For details, see chapter 5.2.2 Logging in.

Depending on the password level entered, it is also possible to confirm completion of monthly maintenance (by the operator) or annual maintenance (by the service personnel).

Proceed as follows:

- 1 Press the "Maintenance" button. Depending on the password level, either the "Monthly maintenance completed?" or the "Annual maintenance completed?" dialog box will open.
- 2 If you have completed maintenance, press "Yes". The warning message in the main screen will then disappear and the time stamp is reset (see also the section on the "Maintenance" diagnostics menu).

The display switches to the "Parameter reset" menu.

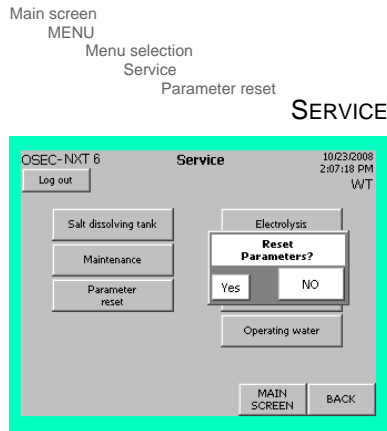

To reset the system to the factory default settings press the "Parameters" button. You will be asked to enter a user name and password. For details, see chapter 5.2.2 Logging in.

Proceed as follows:

- 1 Press the "Parameter reset" button. This opens the "Reset Parameters?" screen.
- 2 To confirm that you wish to change the parameters, press "Yes".

The display then reverts to the "Service" menu.

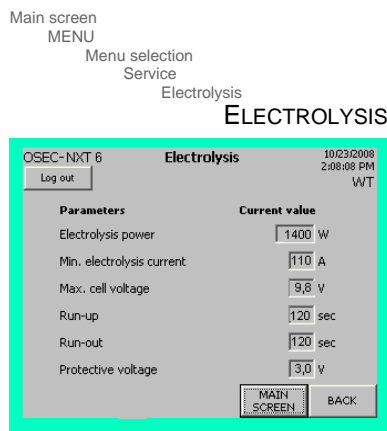

The "Electrolysis" menu is used to set all of the key parameters for the electrolysis process. These settings are configured at the factory and are system-specific. They are therefore password protected and only accessible to level 3 service personnel.



Attention!

Risk of injury and damage to the system!

These settings may only be changed by Evoqua service personnel or by personnel trained and authorized by Evoqua after consulting the manufacturer.

Main screen
 MENU
 Menu selection
 Service
 Brine pump

BRINE PUMP

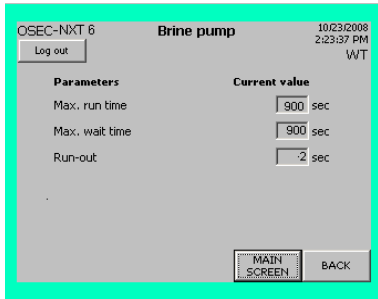

The "Brine pump" menu is used to configure the brine pump. These settings are configured at the factory and are system-specific. They are therefore password protected and only accessible to level 3 service personnel.

Main screen
 MENU
 Menu selection
 Service
 Operating water

OPERATING WATER

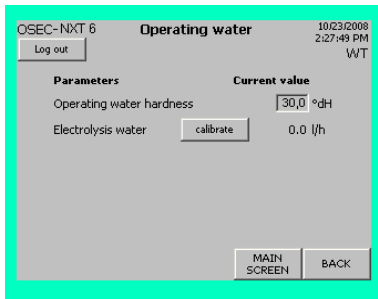

The "Operating water" menu is used to enter the total operating water hardness (factory default 30° dH) and to calibrate the flow meter for the electrolysis water, if necessary. You will be asked to enter a user name and password. For details, see chapter 5.2.2 Logging in.

As part of the monthly maintenance it is necessary to check the water hardness of the operating water being supplied to the system and to enter the value, which should be between 1 and 66° dH, in this menu. See chapter 5.13.4 "Measuring the operating water hardness" for details on measuring the operating water hardness.

Main screen
 MENU
 Menu selection
 Service
 Operating water
 calibrate

CALIBRATION

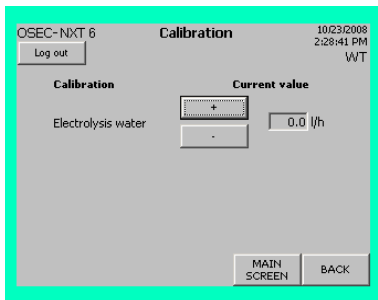

As part of the monthly maintenance it is necessary to check the flow meter measurements and, if necessary, recalibrate it in the "Calibration" menu. See chapter 5.13.5 "Calibrating the flow meter" for details on calibrating the flow meter.

5.12.5 "System" menu

Main screen
MENU
Menu selection
System

SYSTEM

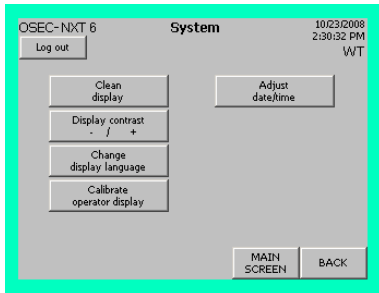

In the "System" menu you can configure the control and display unit.

The "System" menu has the following submenus:

- Clean display
- Decrease/increase display contrast -/+
- Change display language
- Calibrate operator display
- Adjust date/time

Main screen
MENU
Menu selection
System
Clean display

SYSTEM

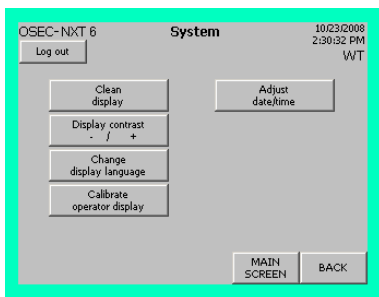

Proceed as follows:

- 1 Press the "Clean display" button. A protective screen is displayed. Cleaning the display takes 30 seconds. The control and display unit cannot be used while cleaning is taking place.
- 2 Once cleaning is complete the display reverts to the "System" menu.

Main screen
MENU
Menu selection
System
Display contrast - / +

SYSTEM

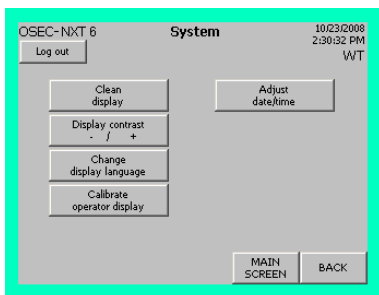

Proceed as follows:

- 1 To decrease or increase the display contrast as necessary, press the corresponding part of the "Display contrast - / +" button.

Main screen
MENU
Menu selection
System
Change display language
SYSTEM

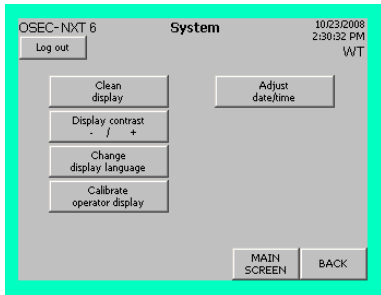

The factory default setting is German. If necessary, the language can be changed. The languages available are:

- German
- English
- French
- Swedish

Proceed as follows:

- 1 Press the "Change display language" button. The language selection dialog box is displayed for 10 seconds.
- 2 Press the language you wish to select. The display then reverts to the main screen.

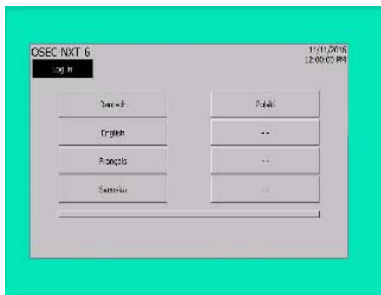

Please Note

The operator display is optimized for an operator of average height. This setting should only be changed if there is a significant difference, for example, if the chlorine membrane electrolysis system is installed at an unusual height.

Main screen
MENU
Menu selection
System
Calibrate operator display
SYSTEM

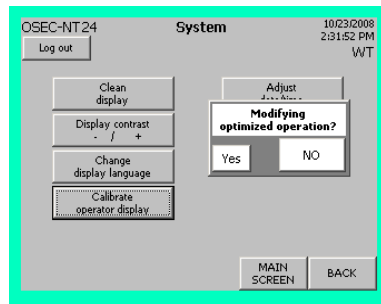

You will be asked to enter a user name and password. For details, see chapter 5.2.2 Logging in.

Proceed as follows:

- 1 Press the "Calibrate operator display" button. The "Modifying optimized operation?" dialog box opens.
- 2 To confirm that you wish to change the settings, press "Yes".

Main screen

MENU

Menu selection

System

Adjust date/time

DATE/TIME

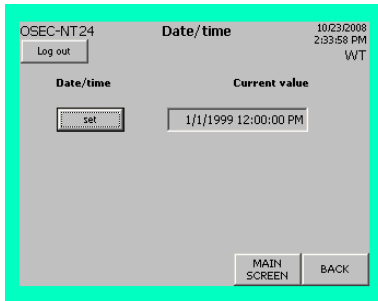

You will be asked to enter a user name and password. For details, see chapter 5.2.2 Logging in.

Proceed as follows:

- 1 Press the „Adjust date/time“ button.
- 2 Enter the correct date and time in the input box in the "Date/time" menu using the keyboard displayed.
- 3 Press the "Set" button to confirm. The time displayed on screen is updated immediately.

5.12.6 "Manual functions" menu



Please Note

The "Manual functions" button is only displayed on the "Menu selection" screen when the system is in "MANUAL" mode. It is not displayed when the system is in Automatic mode.

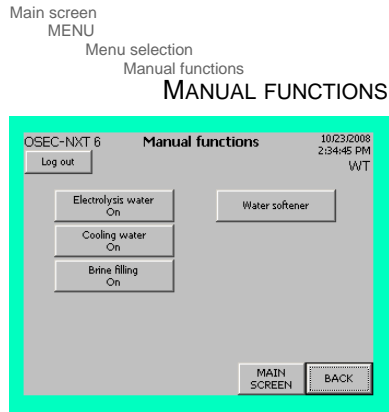

The "Manual functions" menu has the following submenus:

- Electrolysis water On
- Cooling water On
- Brine filling On
- Water softener

The manual functions are only active in MANUAL mode when the system is in the "Preparation off" state. They can be used to enable the required function temporarily.

The manual functions are password protected. You will be asked to enter a user name and password. For details, see chapter 5.2.2 Logging in.

If a manual function is active the status message "Manual mode active" is displayed in the main screen and the "i" (Info) button flashes. Which manual functions is currently active can be displayed in the operating messages menu by pressing the "i" (Info) button.

Main screen
MENU
Menu selection
Manual functions
Electrolysis water On
MANUAL FUNCTIONS

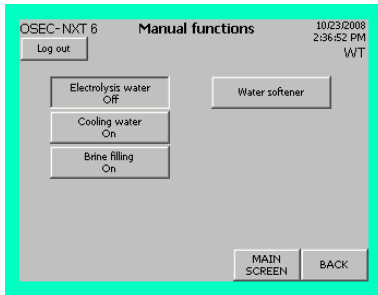

Electrolysis water can be turned on manually either for diagnostic purposes or when performing maintenance, for instance to set the flow rate or to calibrate the flow meter.

Proceed as follows:

- 1 Press the "Electrolysis water On" button. Open the electrolysis water solenoid valve (E2) and the water softener water inlet solenoid valve (E5). The electrolysis water starts flowing.
- 2 To stop the "MANUAL Electrolysis water" function again, press the "Electrolysis water Off" button.



Attention!

Please note that the electrolysis water dilutes the sodium hydroxide in the electrolysis cell, which may interfere with the electrolysis process.



Please Note

Please note that the electrolysis water flows over the electrolysis cell in the reactor and on into the storage tank, thus diluting the product.

Main screen
MENU
Menu selection
Manual functions
Cooling water On
MANUAL FUNCTIONS

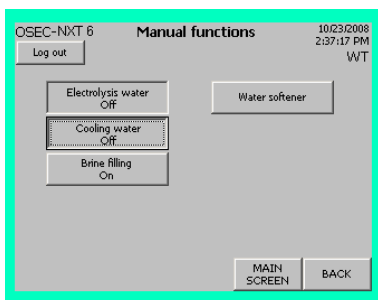

The cooling water can be turned on manually, either for diagnostic purposes or when performing maintenance.

Proceed as follows:

- 1 Press the "Cooling water On" button.
- 2 The cooling water solenoid valve (E3) is opened. The cooling water is flowing.
- 3 To stop the "MANUAL Cooling water" function again, press the "Cooling water Off" button.

Main screen
 MENU
 Menu selection
 Manual functions
 Brine filling On
MANUAL FUNCTIONS

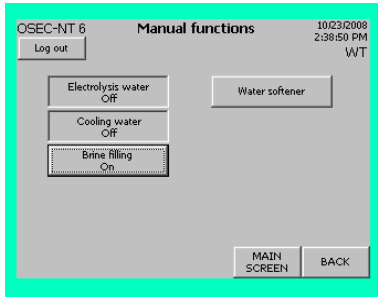

The brine pump can be turned on manually, either for diagnostic purposes or when performing maintenance.

Proceed as follows:

- 1 Press the "Brine filling On" button.
- 2 The brine pump supplies brine to the chlorine separator.
- 3 To stop the "Manual brine pump" function again, press the "Brine filling Off" button.



Please Note

When the maximum fluid level is reached the brine pump is turned off automatically by the level switch in the chlorine separator.

Main screen
MENU
Menu selection
Manual functions
Water softener
Regenerate water softener

MANUAL WATER SOFTENING

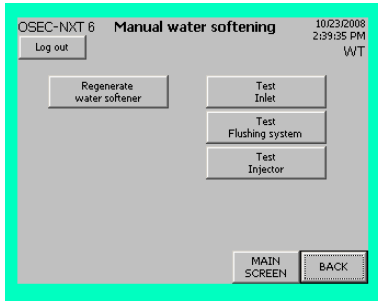

Automatic regeneration of the water softener is usage-based and depends on the water hardness. Regeneration of the water softener can also be started manually.

This menu also contains a number of options which the service personnel can use to test the water softener.

The "Manual water softening" menu has the following submenus:

- Regenerating the water softener
- Test Inlet
- Test Flushing system
- Test Injector

Proceed as follows:

- 1 Press the "Regenerating the water softener" button. The regeneration process takes about 50 minutes.

While regeneration is running the status message "Water softener regenerating" is displayed on the main screen. Press the "i" (Info) button to show the current regeneration phase:

Main screen
"i" (info) operating messages
OPERATING MESSAGES

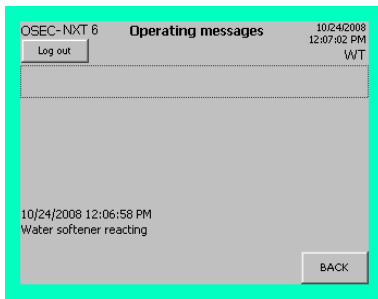

- Water softener reacting

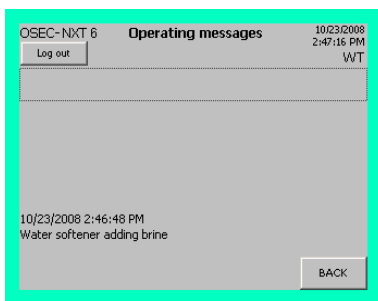

- Water softener adding brine

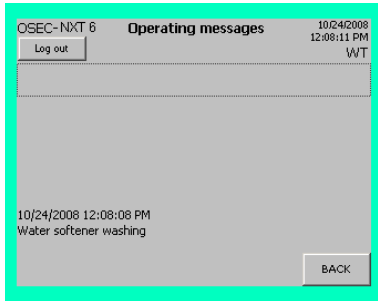

- Water softener washing

Main screen
 MENU
 Menu selection
 Manual functions
 Water softener
 Test Inlet
MANUAL WATER SOFTENING

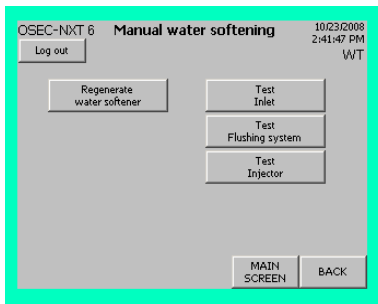

Testing the water softener water inlet solenoid valve (E5).

Proceed as follows:

- 1 Press and hold the "Test Inlet" button. This is a key function. If the water softener water inlet solenoid valve (E5) is working correctly it will open and the LED on the valve will switch on. The valve will close again as soon as the button is released.

Main screen
 MENU
 Menu selection
 Manual functions
 Water softener
 Test Flushing system
MANUAL WATER SOFTENING

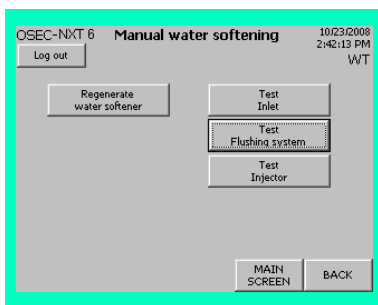

Testing the water softener flushing solenoid valve (E8).

Proceed as follows:

- 1 Press and hold the "Test flushing system" button. This is a key function. If the water softener flushing solenoid valve (E8) is working correctly it will open and the LED on the valve will switch on. The valve will close again as soon as the button is released.

Main screen

MENU

Menu selection

Manual functions

Water softener

Test Injector

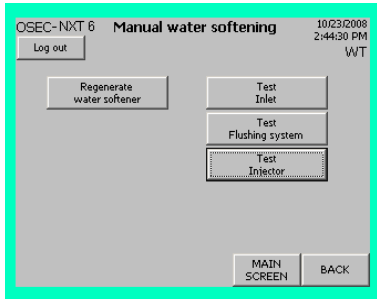
MANUAL WATER SOFTENING

Testing the injector. This tests the:

- Water softener injector solenoid valve (E6)
- Water softener flushing solenoid valve (E8)
- Clean the
- Injector limit contact

Proceed as follows:

- 1 Press and hold the "Test Injector" button. This is a key function. If the injector is working correctly, then
 - The water softener water inlet solenoid valve (E6) will open and the LED on the valve will switch on.
 - The water softener flushing solenoid valve (E8) will open and the LED on the valve will switch on.
 - Brine will be sucked in
 - once the limit contact is reached the error message "Water softener brine flow switch plausibility" is displayed and the valves close again.

5.13 Maintenance by the operator

Maintenance is divided into two levels:

- Maintenance level 1
Performed by trained and instructed operators.
- Maintenance level 2
Performed by Evoqua service personnel or by personnel trained and authorized by Evoqua for maintenance work

The liability for defects is only valid if maintenance work is performed as specified.



Please Note

Inspections are to be carried out while the system is running!

5.13.1 Maintenance overview

daily

Required work	See chapter
<ul style="list-style-type: none"> • Visual inspection of the entire chlorine membrane electrolysis system, including salt dissolving tank, storage tank and hydrogen vent pipe, for leak-tightness and damage • Are there any warning messages or error messages? See the warning and error message logs • Check the operating water pressure according to the specifications on the pressure reducer. Adjust if necessary <ul style="list-style-type: none"> • Operating water (M3): 3.5 bar • Check the electrolysis water flow rate according to the specifications provided by the system. Adjust if necessary <ul style="list-style-type: none"> • Electrolysis water flow meter (M7) • Check that the fill level in the brine tank is at least at 30 to 40cm. Replenish if necessary 	<p>4.7.6</p> <p>4.7.7</p> <p>5.13.2</p>

weekly

Required work	See chapter
• Replenish salt in the salt dissolving tank	5.13.2
• Check the electrolysis current and cell voltage and enter the readings in the operating journal	5.11
• Check the preparation and total operating hours and enter in the operating journal	5.12.3
• Measure soft water hardness and enter the value into the operating journal	5.13.3

monthly

Required work	See chapter
• Measure the hardness of the operating water	5.13.4
• Check the flow meter and recalibrate if necessary	5.13.5.
• Check the filter and clean if necessary	5.13.6
• Reset "Perform monthly maintenance!" warning message	5.12.4

annual

Required work	See chapter
• Request service technician (maintenance level 2)	

*Warning!*

If you find any leaks or damage to the chlorine membrane electrolysis system, switch off automatic preparation immediately by pressing the "Mode" button and contact Evoqua customer services immediately.

*Please Note*

Components and hose connections that are mechanically or electrically operated are labeled on the system with abbreviations (e.g. M3). To facilitate their identification, these abbreviations are repeated at relevant points in the operating instructions and on the drawings.

5.13.2 Replenishing the salt in the salt dissolving tank.



Please Note

Insufficient salt in the salt dissolving tank leads on to malfunctions on the water softener, consequently resulting in irreparable damage to the chlorine membrane electrolysis system and the electrolysis cells.

Check the fill level of the brine in the salt dissolving tank daily! For details see chapter 5.13.2 Replenishing the salt in the salt dissolving tank.



Attention!

To ensure fault-free, safe operation, use only the salt prescribed by the manufacturer (e. g. Evoqua OSEC® Salin) and completely softened water produced by the chlorine membrane electrolysis system.

OSEC® Salin salt pellets Part No.	Quantity
W3T377623	500 kg
W3T164787	1,000 kg
W3T164788	2,000 kg
W3T164789	3,000 kg
W3T164790	5,000 kg

The minimum fill level is 20 cm.

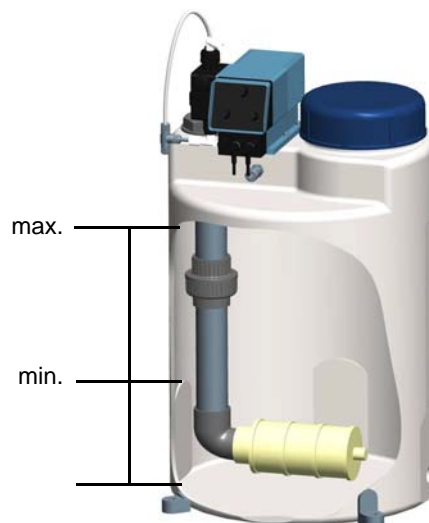

Fig. 3 Salt dissolving tank

Proceed as follows:

- 1 Lift the cover of the salt dissolving tank.
- 2 Replenish the salt. Make sure that no salt falls onto the mounting frame.
- 3 Close the cover of the salt dissolving tank.



Attention!

Do not allow any dirt to get into the salt dissolving tank! Close the cover immediately after replenishing the salt!

5.13.3 Measuring the soft water hardness

As part of the weekly maintenance, the hardness of the soft water needs to be checked. Measurement is possible in every operating state.

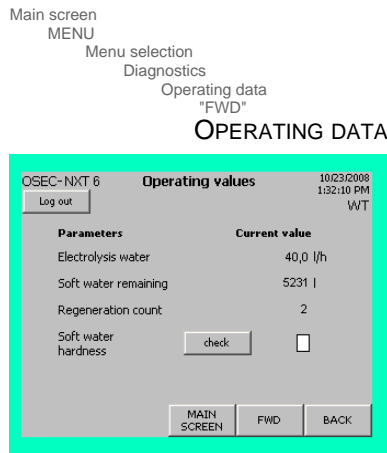

Proceed as follows:

- 1 Switch to the "Operating data" menu. Press the "Check" button. You will be asked to enter a user name and password. For details, see chapter 5.2.2 Logging in. The water softener water inlet solenoid valve (E5) is opened for 300 s and the status indicator changes to black.
- 2 Take a water sample from the soft water sample ball valve (M8).
- 3 Measure the water hardness using the water hardness test kit. Proceed as described in the water hardness test kit's instruction manual.
- 4 Check the value and enter in the operating journal.



Attention!

The soft water hardness should be $< 0.25^{\circ}$ dH. If not, contact Evoqua customer services.

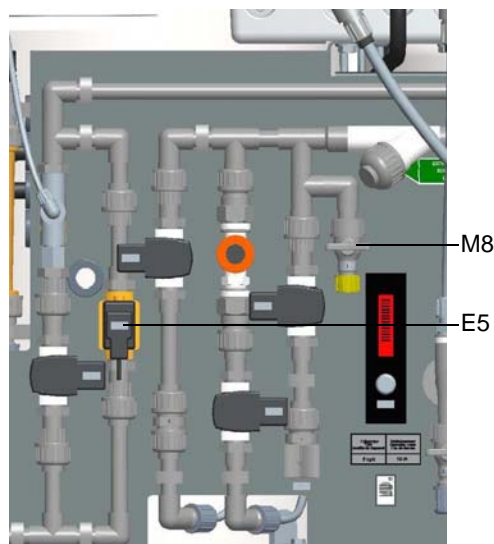

Fig. 4 Cutaway view of the water softener

5.13.4 Measuring the operating water hardness

As part of the monthly maintenance, the water hardness of the operating water supplied to the system needs to be checked and entered on the control and display unit. The operating water hardness can be measured and entered in any operating state.

Proceed as follows:

- 1 Take a water sample at the filter drain tap of the pressure reducing valve (M5).

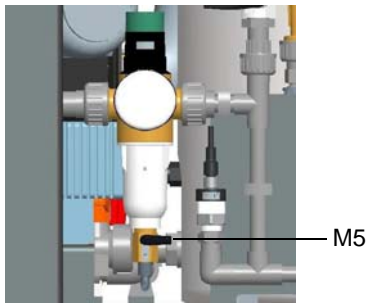
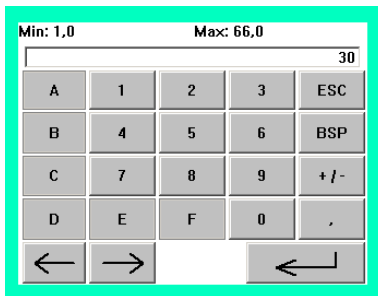
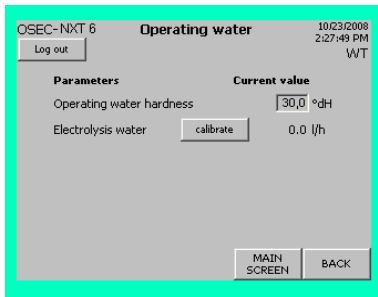

Fig. 5 Cutaway view of the pressure reducing valve showing the filter drain tap

- 2 Measure the water hardness using the water hardness test kit. Proceed as described in the water hardness test kit's instruction manual.

- 3 Switch to the "Operating water" menu and enter the value measured. It should be between 0 and 66° dH. You will be asked to enter a user name and password. For details, see chapter 5.2.2 Logging in.

Main screen
MENU
Menu selection
Service
Operating water
OPERATING WATER



- 4 Enter the measured value in the operating journal.

5.13.5 Calibrating the flow meter

As part of the monthly maintenance it is necessary to check the flow meter measurements and it may be necessary to recalibrate it.

Proceed as follows:

- 1 Check the electrolysis water flow rate and adjust using the electrolysis water flow meter (M7) if necessary. The electrolysis water flow rate for the OSEC-NXT 6 is 12 l/h. See the information labels (A) on the chlorine membrane electrolysis system for details.

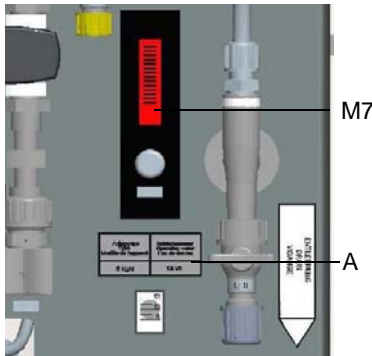

Main screen
MENU
Menu selection
Service
Operating water
OPERATING WATER

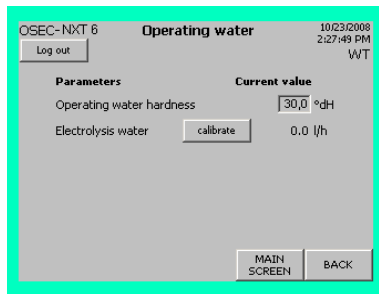

- 2 Switch to the "Operating water" menu. This is where the current electrolysis water flow rate is displayed. If it differs by more than +/- 0.5 l/h from the system-specific setting on the flow meter, press the "calibrate" button. You will be asked to enter a user name and password. For details, see chapter 5.2.2 Logging in.

Main screen
MENU
Menu selection
Service
Operating water
calibrate
CALIBRATION

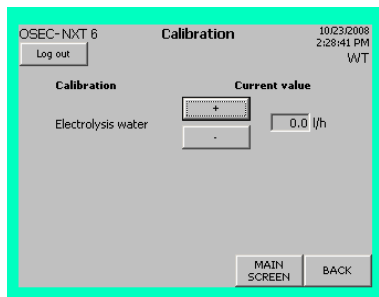

- 3 The flow rate can be adjusted by pressing "+" or "-" in the "Calibration" submenu if necessary.

5.13.6 Checking and cleaning the filters

See chapter 8. Arrangement of components.

As part of the monthly maintenance procedure, check the filters one after another and clean them if necessary:

- Soft water filter
- Operating water pressure reducing valve filter (M3)

Proceed as follows:

Switch off automatic mode

- 1 Press the "Mode" button to switch off automatic mode For details see chapter 5.5 Switching off automatic mode.



Please Note

When dismantling the filters, take note of the sequence of parts and observe this when reassembling!

Soft water filter

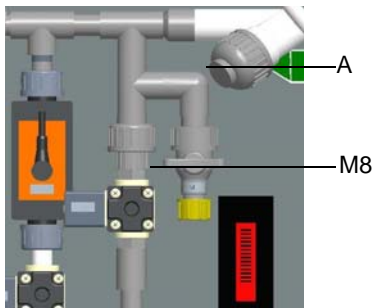

- 1 Open the soft water sample ball valve (M8) and release pressure.
- 2 Reclose soft water sample ball valve (M8).
- 3 Unscrew the filter (A).
- 4 Remove the sieve and rinse under running water.
- 5 Replace the sieve and reinstall the filter.

Operating water pressure reducing valve filter (M3)

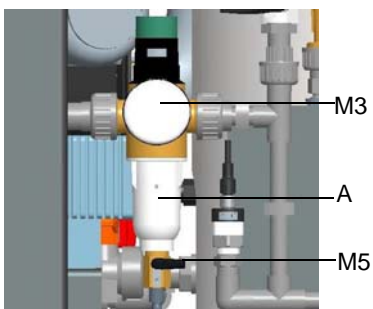

- 1 Interrupt water supply to the chlorine membrane electrolysis system.
- 2 Open and empty pressure reducing valve filter drain tap (M5).
- 3 Close the drain tap filter of the pressure reducing valve (M5).
- 4 Unscrew the transparent filter cup (A).
- 5 Remove the sieve and rinse off under running water.
- 6 Replace the sieve and reinstall the filter.
- 7 Restore water supply to the chlorine membrane electrolysis system.

5.14 Faults



Warning!

Chemical hazard!

A substantial quantity of chemicals is produced in the Chlor-Membranelektrolyse-Anlage. For safe operation and to prevent harm to persons, be sure to follow the safety instructions and warnings on the system and in this operating manual.



Warning!

Risk of injury and damage to the system!

If you find any leaks or damage to the chlorine membrane electrolysis system, switch off automatic preparation immediately by pressing the "Mode" button and contact Evoqua customer services immediately.



Attention!



Damage to the system!

Only in emergencies turn off the main switch!
Otherwise, important safety functions are deactivated.

There are basically two different types of faults:

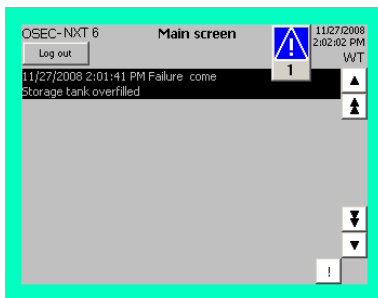
- Faults that trigger the stopping of preparation. The chlorine membrane electrolysis system switches to the "Preparation standby" operating status. Automatic mode is active. As soon as the fault has been corrected and the "RESET" button has been pressed, preparation can be started again.
- Faults that cause automatic operation to be stopped immediately. The mode changes from Automatic to Manual and the chlorine membrane electrolysis system switches to the "Preparation off" state.



If the system develops a fault, a corresponding error message is displayed in a dialog box, irrespective of the current operating state or what else is currently being displayed by the system. Every error message has to be acknowledged individually by pressing the  button. Once the last error message has been acknowledged the display returns to the last menu that was displayed and the  symbol is displayed.

Main screen

MAIN SCREEN

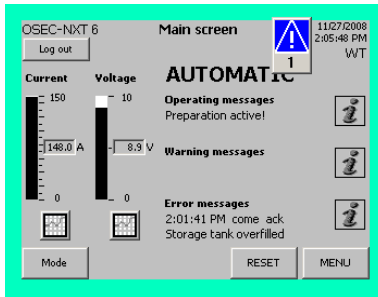

The last error message reported by the system is displayed as a text message on the main screen, together with the time stamp and the state and the "i" (Info) button flashes.

The text message, the symbol and the flashing "i" (Info) button all cease to be displayed once the fault has been cleared and the "RESET" button has been pressed.

If it is not possible to remedy the fault yourself, please contact Evoqua directly.

Main screen

"i" (info) error messages

ERROR MESSAGES

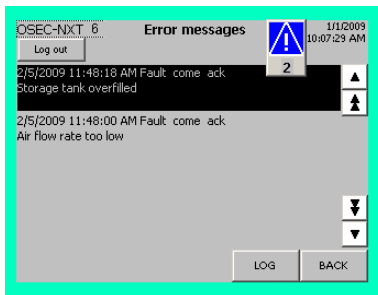

The "i" (Info) button allows you to view the error messages that have been displayed by the system, including the date, time and status details ("come", "ack" and "gone"), at any time.

The arrow keys are used to navigate around the display.

All faults are also stored in the error message log (accessible via the main "Diagnostics" menu) and can be viewed there at any time. See chapter 5.12.3 Error message log.

5.14.1 Faults that cause preparation to stop (AUTOMATIC "Preparation standby")

Error message	caused by	Remedy
Cell voltage too high	<ul style="list-style-type: none"> Limit value exceeded (electrical resistance too high, electrolysis process not working properly) 	<ul style="list-style-type: none"> Contact Evoqua customer services immediately
Electrolysis current too low	<ul style="list-style-type: none"> Below limit value (electrical resistance too high, electrolysis process not working properly) 	<ul style="list-style-type: none"> Contact Evoqua customer services immediately
Electrolysis water flow rate too low	<ul style="list-style-type: none"> Significantly below set value 	<ul style="list-style-type: none"> Adjust electrolysis water flow rate as described in chapter 4.7.7. Check the warning message log
Electrolysis water flow rate too low Operating water pressure: 1.99 bar! Warning for 1.23 hours	<ul style="list-style-type: none"> Significantly below set value due to the operating water pressure being too low 	<ul style="list-style-type: none"> Adjust electrolysis water flow rate as described in chapter 4.7.7. Check the operating water pressure (M3) during operation and, if necessary, reset according to the system specifications
Electrolysis water flow rate too high	<ul style="list-style-type: none"> Significantly above set value 	<ul style="list-style-type: none"> Adjust electrolysis water flow rate as described in chapter 4.7.7. Check the operating water pressure (M3) during operation and, if necessary, reset according to the system specifications
Electrolysis water check flow meter	<ul style="list-style-type: none"> No signal from flow meter 	<ul style="list-style-type: none"> Check electrolysis water flow rate and adjust at the electrolysis water flow meter (M7) if necessary. Have the operating water solenoid valve (E2) checked by an electrical technician.

Error message	caused by	Remedy
<p>Storage tank level probes plausibility</p>	<ul style="list-style-type: none"> • Simultaneous indication of different fill levels 	<ul style="list-style-type: none"> • The switching functions of the level switches in the storage tank should be checked by an electrical technician.
<p>External water softener / hardness control failure</p>	<ul style="list-style-type: none"> • Fault message from external water softener • Fault message from external residual hardness control device 	<ul style="list-style-type: none"> • Notify manufacturer / supplier immediately • Make sure that softened water is being supplied to the salt dissolving tank
<p>Salt dissolving tank filling time exceeded Check brine level!</p>	<ul style="list-style-type: none"> • Limit value for the filling time of the salt dissolving tank has been exceeded 	<ul style="list-style-type: none"> • Check level! • Check salt dissolving tank and filling system for leaks • Salt dissolving tank level switch faulty • Check the warning message log • If necessary, contact Evoqua customer services
<p>Salt dissolving tank filling time exceeded. Check brine level! Operating water pressure: 1.99 bar!</p>	<ul style="list-style-type: none"> • Limit value for the filling time of the salt dissolving tank has been exceeded because operating water pressure is too low 	<ul style="list-style-type: none"> • Check level! • Check the operating water pressure (M3) during operation and, if necessary, reset according to the system specifications
<p>Rectifier not ready</p>	<ul style="list-style-type: none"> • Rectifier is faulty 	<ul style="list-style-type: none"> • Contact Evoqua customer services immediately • Check the warning message log
<p>Rectifier not ready Mains voltage/mains failure</p>	<ul style="list-style-type: none"> • Rectifier not ready because: <ul style="list-style-type: none"> • The mains voltage is outside the tolerances (over/undervoltage) • Phase failure/neutral conductor failure • Phase sequence incorrect 	<ul style="list-style-type: none"> • Have the power supply required connected by an authorized and qualified electrical technician.

Error message	caused by	Remedy
<p>Rectifier not ready Ambient temperature: 42°C Warning for 1.23 hours</p>	<ul style="list-style-type: none"> Rectifier not ready due to: <ul style="list-style-type: none"> Maximum permissible ambient temperature exceeded 	<ul style="list-style-type: none"> Ensure there is a supply of fresh air Measure the ambient temperature and cool the air in the room if necessary
<p>Brine pump run time exceeded</p>	<ul style="list-style-type: none"> Max. brine pump running time exceeded 	<ul style="list-style-type: none"> Check that the pump's on/off switch is in position "1"
<p>Brine pump wait time exceeded</p>	<ul style="list-style-type: none"> Max. brine pump wait time exceeded 	<ul style="list-style-type: none"> Contact Evoqua customer services immediately
<p>Automatic Stopcock will not open</p>	<ul style="list-style-type: none"> Automatic stopcock open/closed position not confirmed 	<ul style="list-style-type: none"> Have the automatic stopcock checked by Evoqua customer services
<p>Automatic Stopcock will not close</p>	<ul style="list-style-type: none"> Automatic stopcock open/closed position not confirmed 	<ul style="list-style-type: none"> Have the automatic stopcock checked by Evoqua customer services

5.14.2 Faults that cause automatic operation to stop immediately (MANUAL, "Preparation off")

Error message	caused by	Remedy
Dosing leak	<ul style="list-style-type: none"> Feedback from the leak sensor in the dosing area 	<ul style="list-style-type: none"> Close the storage tank discharge tap Perform visual inspection of the pipes to check for leaks Contact Evoqua customer services
Plant leak	<ul style="list-style-type: none"> Signal from the leak sensor of the chlorine membrane electrolysis system. 	<ul style="list-style-type: none"> Perform visual inspection to check for leaks Check that valves and screw connections are closed. Close if necessary. Contact Evoqua customer services
Storage tank leak	<ul style="list-style-type: none"> Signal from the leak sensor on the storage tank 	<ul style="list-style-type: none"> Perform visual inspection to check for leaks Check that valves and screw connections are closed. Close if necessary. Contact Evoqua customer services
Storage tank overfilled	<ul style="list-style-type: none"> Signal from the level probe in the storage tank: <ul style="list-style-type: none"> Level probe "Max." faulty 	<ul style="list-style-type: none"> Put on protective clothing The switching functions of the level probe "Max." in the storage tank should be checked by an electrical technician.
Check air flow monitor	<ul style="list-style-type: none"> Air flow monitor sensor signals an air current although the fan is turned off 	<ul style="list-style-type: none"> Screw the paddle switch out of the air flow monitor and check the spring force. Clean carefully if necessary. Contact Evoqua customer services immediately
Air flow rate too low	<ul style="list-style-type: none"> Air flow monitor reports no or low air flow 	<ul style="list-style-type: none"> Perform visual inspection of the hydrogen vent pipe Check if the vent opening is blocked Check if the fan is blocked Check if the fan is rotating

Error message	caused by	Remedy
<p style="text-align: center;">Fan failure</p>	<ul style="list-style-type: none"> • Electrical fault 	<ul style="list-style-type: none"> • Contact Evoqua customer services immediately
<p style="text-align: center;">EMERGENCY STOP</p>	<ul style="list-style-type: none"> • Missing "Release system" signal 	<ul style="list-style-type: none"> • Check if external release has been withdrawn by an external switch function
<p style="text-align: center;">Chlorine gas alarm</p>	<ul style="list-style-type: none"> • Signal from the gas alert device due to increased chlorine concentration in the air. 	<ul style="list-style-type: none"> • Put on protective clothing • Bring any bystanders to safety • Create a fresh air supply • Contact Evoqua customer services immediately

5.14.3 Faults that occur outside the preparation process

Error message	caused by	Remedy
<p>Water softener brine flow switch plausibility</p>	<ul style="list-style-type: none"> • Adjustment of the limit value sensor of the brine inlet softener (E10) 	<ul style="list-style-type: none"> • Visual inspection of the limit sensor (Max. at 20 l/h) • Contact Evoqua customer services
<p>Water softener brine flow rate too low</p>	<ul style="list-style-type: none"> • Below the set limit due to <ul style="list-style-type: none"> • a lack or shortage of brine/empty salt dissolving tank • Faulty brine inlet pipe • Water softener drain dirty or back-pressure 	<ul style="list-style-type: none"> • Check the fill level of the brine in the salt dissolving tank • Perform a visual inspection of the brine supply pipes for leaks. • Check water softener drain • Check the warning message log • Contact Evoqua customer services
<p>Water softener Brine flow rate too low! Operating water pressure: 1.99 bar! Warning for 1.23 hours</p>	<ul style="list-style-type: none"> • Below the set limit due to <ul style="list-style-type: none"> • the operating water pressure being too low 	<ul style="list-style-type: none"> • Check operating water pressure (M3) and, if necessary, reset according to the specifications on the system • Contact Evoqua customer services
<p>Electrolysis water flow meter plausibility</p>	<ul style="list-style-type: none"> • Sensor reports flow rate though the valves are closed 	<ul style="list-style-type: none"> • Have the inlet solenoid valve checked for leaks by an electrical technician



Please Note

All faults must be recorded in the operating journal!



Attention!

If the system needs to be shut down for longer than four weeks, it must be shut-down by trained and authorized personnel or by Evoqua service personnel. For further details see chapter Maintenance, 6.5 Shut-down.

6. Maintenance by a service technician

6.1 Performing maintenance

Regular maintenance of the chlorine membrane electrolysis system is a precondition for the customer to be able to make claims for defects. Level 2 maintenance must be performed once a year by Evoqua service personnel or by personnel that have been trained and authorized by Evoqua for maintenance work. This is first required six months after the system is commissioned.

Main screen

MAIN SCREEN

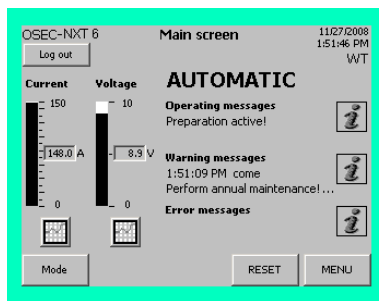

This is displayed on the screen. This warning message will be displayed for the first time after six months, and then every twelve months. The chlorine membrane electrolysis system remains operational. The warning message is turned off again once you have confirmed that annual maintenance has been carried out by pressing the "Maintenance" button on the main "Service" menu, see chapter 5.12.4 "Service menu".

You can check when the next monthly or annual maintenance is due at any time by selecting "Operating data" in the "Diagnostics" menu.

Maintenance part sets

The parts required for performing annual maintenance are included in the maintenance parts sets. A distinction is made between the maintenance parts sets for wear parts for use after 1 year, after 2 years and after 5 years. In addition to this, there are also a pump head service set and a replacement rectifier fan available. See chapter 6.2 Maintenance parts sets for details.

Additional tools

The following additional tools are required to perform annual maintenance:

- Multimeter
- Clamp-on ammeter
- Thermometer
- Titration kit for chlorine
- Salinometer, density range 1.180 to 1.240 g/cm³
- Hose 6/8
- Hose 6/8 for connection to a 1/2" screw connection
- Empty sodium hydroxide canister
- 20 l bucket
- Stop watch

Maintenance checklist

The procedure and scope of annual maintenance is specified in maintenance checklist VD304-1. The specified sequence must be adhered to! Details on performing the various steps of the maintenance procedure are given in chapter 6.3 Detailed maintenance work.

The maintenance checklist must be properly completed and signed and then returned to Evoqua Water Technologies GmbH (required for any defect liability claims).

Starting the system up again

Once the maintenance has been completed, the chlorine membrane electrolysis system can be started up again as described in chapter 6.6 Starting the system up again. Reset the warning message by pressing the "Maintenance" button on the main "Service" menu.



Warning!

Chemical hazard!

A substantial quantity of chemicals is produced in the Chlor-Membranelektrolyse-Anlage. For safe operation and to prevent harm to persons, be sure to follow the safety instructions and warnings on the system and in this operating manual.



Warning!

Risk of injury or damage to the system!

Level 2 maintenance may only be performed by authorized specialized personnel qualified for maintenance. All electrical work on the chlorine membrane electrolysis system may only be performed by qualified electricians. Modifications to the system which go beyond those described in this manual are not permissible. (See also chapter 2.2 General safety instructions)



Please note

Document all modifications or other work on the checklist and in the operating journal!

6.2 Maintenance parts sets

The parts required for performing annual maintenance are included in the maintenance parts sets. The following maintenance parts sets are available:

Part No.	Designation
W3T166568	Maintenance parts set, 1 year (or for the first time after 6 months)
W3T166569	Maintenance parts set, 2 years
W3T166570	Maintenance parts set, 5 years
W3T364541	Rectifier fan
W3T185826 ^a	Pump head service set

a. The brine pump has a two year maintenance interval. The pump head service set is therefore included in the maintenance parts set for 2 years (W3T166569).

The table in chapter 6.2.5 Using the maintenance parts sets provides details on when which maintenance parts set should be used.

All of the parts in the maintenance parts sets must be replaced or used.

6.2.1 Maintenance parts set for 1 year

The item numbers in the table refer to the drawings in chapter 6.3.8 Replacing wear parts.

Maintenance parts set W3T166568, 1 year					
Item	Quantity	Part No.	Designation	Application	See chapter
1	1	W3T168367	Float, PVDF	Replacing wear parts	6.3.8
2	1	W3T168368	Securing ring		
3	1	W3T169285	Water hardness test kit	Measuring the water hardness	5.13.3 5.13.4
4	1	W3T173010	O-ring 28.17x3.53 FPM	Replacing wear parts	6.3.8
5	4	W3T322056	Washer M5, PVDF		
7	1	W2T505082	Spiral hose d 110, PVC-P		
8	1	W3T163644	Sodium thiosulphate, 300 g	Anolyte neutralization	6.3.7
10	1	W3T168863	O-ring 12x3 FPM	Replacing wear parts	6.3.8
11	1	W3T168572	O-ring 60.05x1.78, EPDM		
18	1	W3T169064	Sieve tube		
27	4	W3T322055	Nut DIN 555, M5, PVDF		
31	1	W3T164321	Suction/pressure valve		

6.2.2 Maintenance parts set for 2 years

The item numbers in the table refer to the drawings in chapter 6.3.8 Replacing wear parts.

Maintenance parts set W3T166569, 2 years					
Item	Quantity	Part No.	Designation	Application	See chapter
1	1	W3T168367	Float, PVDF	Replacing wear parts	6.3.8
2	1	W3T168368	Securing ring		
3	1	W3T169285	Water hardness test kit	Measuring the water hardness	5.13.3 5.13.4
4	1	W3T173010	O-ring 28.17x3.53 FPM	Replacing wear parts	6.3.8
5	4	W3T322056	Washer M5, PVDF		
6	1	W3T169416	Volumetric flow control		
7	1	W2T505082	Spiral hose d 110, PVC-P		
8	1	W3T163644	Sodium thiosulphate, 300 g		
9	1	W3T185826	Pump head service set	Brine pump maintenance	6.3.9
10	1	W3T168863	O-ring 12x3 FPM	Replacing wear parts	6.3.8
11	1	W3T168572	O-ring 60.05x1.78, EPDM		
12	9	W3T172822	O-ring 15.54x2.62 FPM		
13	4	W3T172723	O-ring 12.37x2.62 FPM		
14	11	W3T172861	O-ring 11.3x2.4, FPM		
16	2	W3T172988	Flat gasket 30x21x3 EPDM		
17	2	W3T172724	O-ring 20.22x3.53 FPM		
18	1	W3T169064	Sieve tube		
19	1	W3T172949	O-ring 4.47x1.78, EPDM		
20	1	W3T172975	O-ring 8x1.5, EPDM		
27	4	W3T322055	Nut DIN 555, M5, PVDF		
30	1	W3T169068	O-ring 13.94x2.62, FPM		
31	1	W3T164321	Suction/pressure valve		

6.2.3 Maintenance parts set for 5 years

The item numbers in the table refer to the drawings in chapter 6.3.8 Replacing wear parts.

Maintenance parts set W3T166570, 5 years					
Item	Quantity	Part No.	Designation	Application	See chapter
3	1	W3T169285	Water hardness test kit	Measuring the water hardness	5.13.3 5.13.4
4	1	W3T173010	O-ring 28.17x3.53 FPM	Replacing wear parts	6.3.8
5	4	W3T322056	Washer M5, PVDF		
7	1	W2T505082	Spiral hose d 110, PVC-P		
8	1	W3T163644	Sodium thiosulphate, 300 g	Anolyte neutralization	6.3.7
10	1	W3T168863	O-ring 12x3 FPM	Replacing wear parts	6.3.8
11	1	W3T168572	O-ring 60.05x1.78, EPDM		
18	1	W3T169064	Sieve tube		
21	1	W3T172401	Suction lance	Replacing the suction lance	6.3.14
22	1	W3T166523	Storage tank complete	Replacing wear parts	6.3.8
23	1	W3T172135	Level switch titanium/PVDF		
24	1	W3T162371	Paddle switch	Replace the paddle switch	6.3.15
25	1	W3T160913	Cation water softener	Replacing wear parts	6.3.8
26	1	W3T168512	Replacement sieve		
27	4	W3T322055	Nut DIN 555, M5, PVDF		
28	1	W3T172370	Flow-through solenoid valve		
29	1	W3T161074	Low-pressure fan		
31	1	W3T164321	Suction/pressure valve		

6.2.4 Rectifier fan

The rectifier fan has a two year maintenance interval. The prescribed maintenance schedule is given in the table in chapter 6.2.5 Using the maintenance part sets. For details on the exchange of the rectifier fan, see chapter 6.3.12 Replacing the rectifier fan.

Chlorine membrane electrolysis system	Fan Part No.
OSEC-NXT 6	W3T364541

6.2.5 Using the maintenance parts sets

Because the different wear parts wear at different rates it is necessary to use different maintenance part sets for different maintenance intervals.

Maintenance interval	Maintenance part sets
1. Year	W3T166568
2. Year	W3T166569 W3T364541
3. Year	W3T166568
4. Year	W3T166569 W3T364541
5. Year	W3T166570
6. Year	W3T166569 W3T364541
7. Year	W3T166568
8. Year	W3T166569 W3T364541
9. Year	W3T166568
10. Year	W3T166570 W3T185826 W3T364541



Please note

All of the parts in the maintenance parts sets must be replaced or used.

6.3 Detailed maintenance work

6.3.1 Measuring individual cell voltage

The chlorine membrane electrolysis system is in AUTOMATIC mode, operating state "Preparation active!".

Proceed as follows:

- 1 Measure the voltage of the individual electrolysis cell via their electrical connections using the multimeter and probes, and while the system is preparing the product.
- 2 Enter the measured values in the maintenance checklist.
- 3 Check the total voltage displayed on the main screen and enter it in the maintenance checklist.



Please note

The electrolysis cells may not have more the 19.5 V.

6.3.2 Measuring the cell current

The chlorine membrane electrolysis system is in AUTOMATIC mode, operating state "Preparation active!".

Proceed as follows:

- 1 Measure the cell current with the clamp-on ammeter and the multimeter while the system is preparing the product.
- 2 Enter the measurements in the maintenance checklist.
- 3 Check the current displayed on the main screen and enter it in the maintenance checklist.



Please note

The current must be approximately 150 A.

6.3.3 Checking the product concentration



Attention!

Risk of injury!

Sodium hypochlorite is a strong oxidant. Avoid all skin contact! Always wear protective clothing! After skin contact, rinse thoroughly with lots of water!

The chlorine membrane electrolysis system is in AUTOMATIC mode, operating state "Preparation active!".

Proceed as follows:

- 1 Unscrew the storage tank cover.
- 2 While system is running, collect a sample of at least 50 ml in a clean container from the opening in the storage tank.
- 3 Close the storage tank cover.
- 4 Carry out titration according to the titration instructions.
- 5 Enter the product concentration measured in the maintenance checklist.
- 6 Dispose of the sample.

6.3.4 Checking the product temperature



Attention!

Risk of injury!

Sodium hypochlorite is a strong oxidant. Avoid all skin contact! Always wear protective clothing! After skin contact, rinse thoroughly with lots of water!

The chlorine membrane electrolysis system is in AUTOMATIC mode, operating state "Preparation active!".

Proceed as follows:

- 1 Unscrew the storage tank cover.
- 2 While system is running, collect a sample of at least 50 ml in a clean container from the opening in the storage tank and dispose of this sample.
- 3 Take another 50-ml sample.
- 4 Measure the product temperature with the thermometer.
- 5 Enter the product temperature measured in the checklist.
- 6 Close the storage tank cover.
- 7 Clean the thermometer thoroughly.
- 8 Dispose of the sample.

6.3.5 Checking the salt dissolving tank level probe

The chlorine membrane electrolysis system is in MANUAL mode, operating state "Preparation off".

Proceed as follows:

- 1 Lift the cover of the salt dissolving tank.
- 2 Lift the level probe out of the guide tube. The level switch must have freedom of movement. The float falls downwards. Softened water flows into the brine tank.
- 3 Insert level sensor into the guide tube again. Softened water continues to flow for about 30 seconds.

6.3.6 Emptying and rinsing the cathode chamber



Attention!

Damage to the electrolysis cell!

Never empty the cathode and anode chambers at the same time!
The membrane could dry out and damage the electrolysis cell!

The chlorine membrane electrolysis system is in MANUAL mode, operating state "Preparation off".

Proceed as follows:

- 1 Attach a hose to the cathode-side outlet (M11) and insert the free end into the empty sodium hydroxide canister provided.
- 2 Open the ball valve of the cathode-side outlet (M11) and empty the cathode chamber completely.
- 3 Close the ball valve of the cathode-side outlet (M11) again.

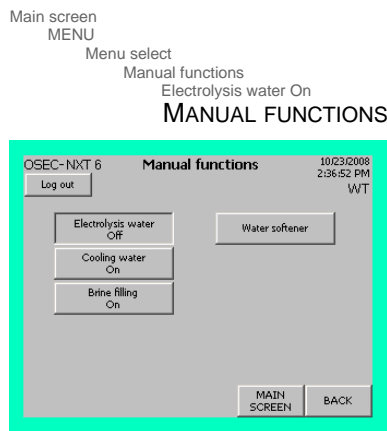

- 4 Switch to the "Manual functions" screen and press the "Electrolysis water On" button. Open the electrolysis water solenoid valve (E2) and the water softener water inlet solenoid valve (E5). The electrolysis water starts flowing.
- 5 Rinse the cathode chamber for about 30 minutes.



Please note

Do not rinse the cathode chamber for longer than 30 minutes, as the product in the storage tank will otherwise be diluted unnecessarily.

- 6 To stop the "MANUAL Electrolysis water" function again, press the "Electrolysis water Off" button. The electrolysis water solenoid valve (E2) and the water softener water inlet solenoid valve (E5) close.
- 7 Leave water in the cathode chamber.

6.3.7 Emptying and rinsing the anode chamber



Warning!

Chemical hazard!

There is chlorine gas in the anolyte circuit. Leaks may release chlorine gas. Chlorine gas is toxic when inhaled and may cause loss of consciousness. Use gas mask!



Attention!

Damage to the electrolysis cell!

Never empty the cathode and anode chambers at the same time! The membrane could dry out and damage the electrolysis cell!



Please note

The individual steps must be followed in the correct sequence.

The chlorine membrane electrolysis system is in MANUAL mode, operating state "Preparation off".

Proceed as follows:

- 1 Put approx. 300g of sodium thiosulphate into an empty 20 l bucket.
- 2 Add about 0.5 l water and stir. The sodium thiosulphate does not completely dissolve.
- 3 Attach a 2 m hose section 6/8 to the separator outlet drain (M9).
- 4 Insert the free hose end in the solution. Ensure that the hose does not slide out.
- 5 Open the separator drain outlet (M9) and empty the anode chamber completely.
- 6 Dispose of the contents of the drum in the sewage system and rinse with water.
- 7 Create a hose connection between the separator drain outlet (M9) and the soft water sample outlet ball valve (M8).
- 8 Completely close the electrolysis water control wheel (M7) on the flow meter.

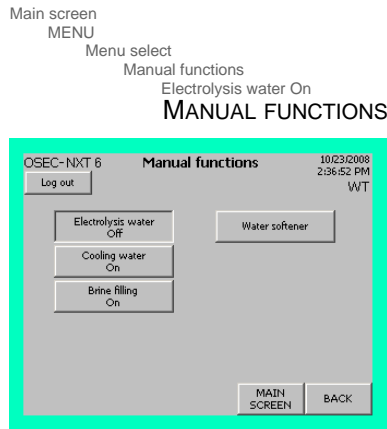

9 Switch to the "Manual functions" screen and press the "Electrolysis water On" button. Open the electrolysis water solenoid valve (E2) and the water softener water inlet solenoid valve (E5). The electrolysis water starts flowing.

10 Rinse the system for at least 30 minutes.

11 Reset flow at flow meter to nominal value (see the information signs on the chlorine membrane electrolysis system).

12 To stop the "MANUAL Electrolysis water" function again, press the "Electrolysis water Off" button. The electrolysis water solenoid valve (E2) and the water softener water inlet solenoid valve (E5) close.

13 Leave water in the anode chamber.

6.3.8 Replacing the wear parts

Drain and rinse the chlorine membrane electrolysis system and switch off at the main switch. The operating water supply stops.

The wear parts contained in the prescribed maintenance parts sets need to be replaced as shown in the drawings below.

Proceed as follows:

- 1** Replace items 14, 19 and 20 first by draining the water from the cathode chamber and then refilling it with sodium hydroxide after having replaced the parts. For details, see chapter 4.7.11 Emptying the water-filled cathode chamber and filling with sodium hydroxide.
- 2** Replace items 1, 2, 4, 10 and 23 by draining the water from the anode chamber as described in chapter 4.7.15. It is refilled with brine when the system is started up again. For details, see chapter 6.6 Starting the system up again.
- 3** The remaining wear parts can be replaced in any order.



Please note

Grease the o-rings, item No. 12, on the brine flow meter with silicone grease before installation!



Please note

Replace the suction lance as described in chapter 6.3.14.

1-year maintenance

During 1-year maintenance the following wear parts from maintenance part set W3T166568 need to be replaced, as shown in the drawings below.

Item	Quantity	Part No.	Designation
1	1	W3T168367	Float, PVDF
2	1	W3T168368	Securing ring
4	1	W3T173010	O-ring 28.17x3.53 FPM
5	4	W3T322056	Washer M5, PVDF
7	1	W2T505082	Spiral hose d 110, PVC-P
10	1	W3T168863	O-ring 12x3 FPM
11	1	W3T168572	O-ring 60.05x1.78, EPDM
18	1	W3T169064	Sieve tube
27	4	W3T322055	Nut DIN 555, M5, PVDF
31	1	W3T164321	Suction/pressure valve

2-year maintenance

During 2-year maintenance the following wear parts from maintenance part set W3T166569 need to be replaced, as shown in the drawings below.

Item	Quantity	Part No.	Designation
1	1	W3T168367	Float, PVDF
2	1	W3T168368	Securing ring
4	1	W3T173010	O-ring 28.17x3.53 FPM
5	4	W3T322056	Washer M5, PVDF
6	1	W3T169416	Volumetric flow control
7	1	W2T505082	Spiral hose d 110, PVC-P
10	1	W3T168863	O-ring 12x3 FPM
11	1	W3T168572	O-ring 60.05x1.78, EPDM
12	9	W3T172822	O-ring 15.54x2.62 FPM
13	4	W3T172723	O-ring 12.37x2.62 FPM
14	11	W3T172861	O-ring 11.3x2.4, FPM
16	2	W3T172988	Flat gasket 30x21x3 EPDM
17	2	W3T172724	O-ring 20.22x3.53 FPM
18	1	W3T169064	Sieve tube

Item	Quantity	Part No.	Designation
19	1	W3T172949	O-ring 4.47x1.78, EPDM
20	1	W3T172975	O-ring 8x1.5, EPDM
27	4	W3T322055	Nut DIN 555, M5, PVDF
30	1	W3T169068	O-ring 13.94x2.62, FPM
31	1	W3T164321	Suction/pressure valve

5-year maintenance

During 5-year maintenance the following wear parts from maintenance part set W3T166570 need to be replaced, as shown in the drawings below.

Item	Quantity	Part No.	Designation
1	1	W3T168367	Float, PVDF
2	1	W3T168368	Securing ring
4	1	W3T173010	O-ring 28.17x3.53 FPM
5	4	W3T322056	Washer M5, PVDF
7	1	W2T505082	Spiral hose d 110, PVC-P
10	1	W3T168863	O-ring 12x3 FPM
11	1	W3T168572	O-ring 60.05x1.78, EPDM
18	1	W3T169064	Sieve tube
22	1	W3T166523	Storage tank complete
23	1	W3T172135	Level switch titanium/PVDF
25	1	W3T160913	Cation water softener
26	1	W3T168512	Replacement sieve
27	4	W3T322055	Nut DIN 555, M5, PVDF
28	1	W3T172370	Flow-through solenoid valve
29	1	W3T161074	Low-pressure fan
31	1	W3T164321	Suction/pressure valve

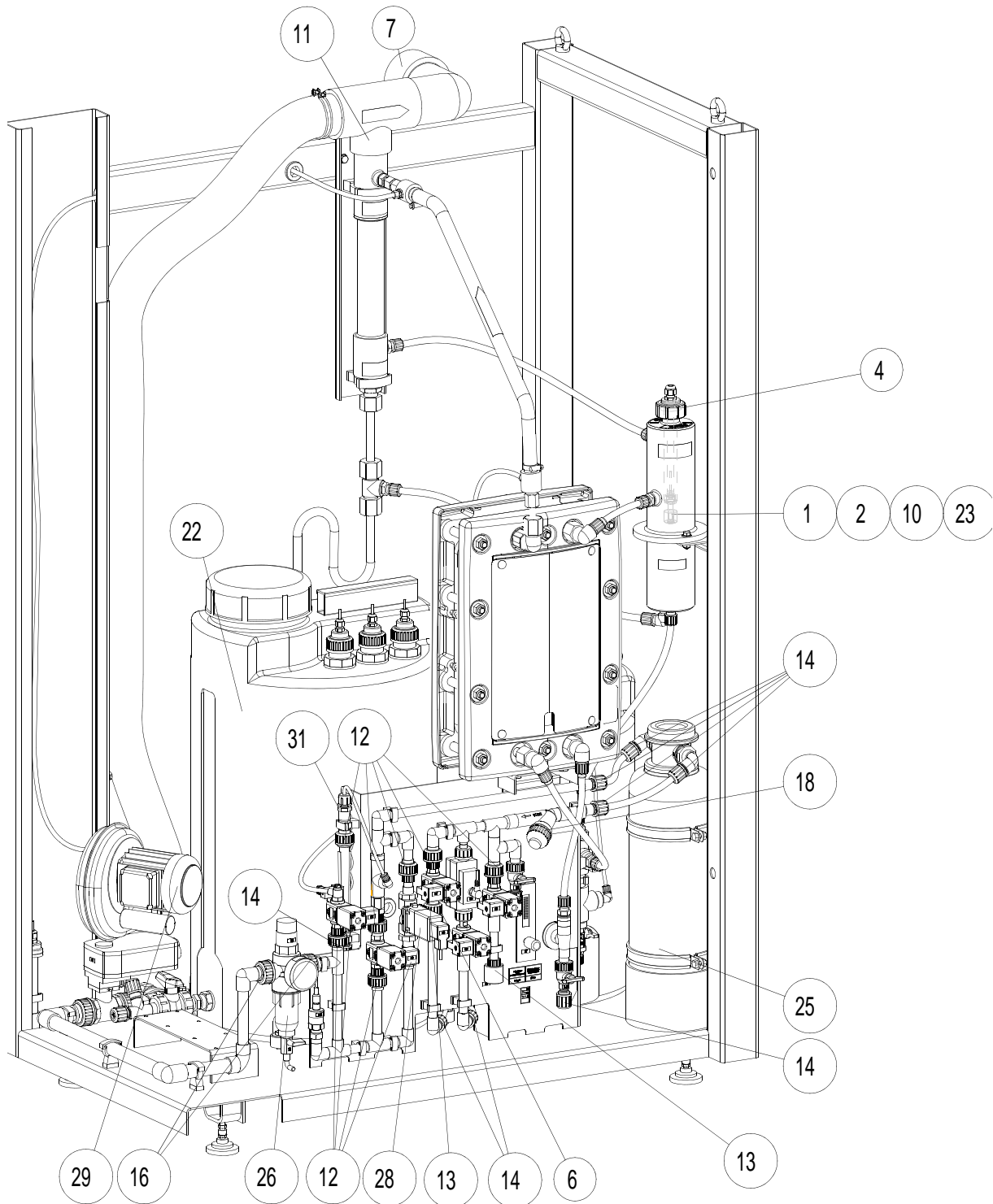

Fig. 1 Wear parts to be replaced

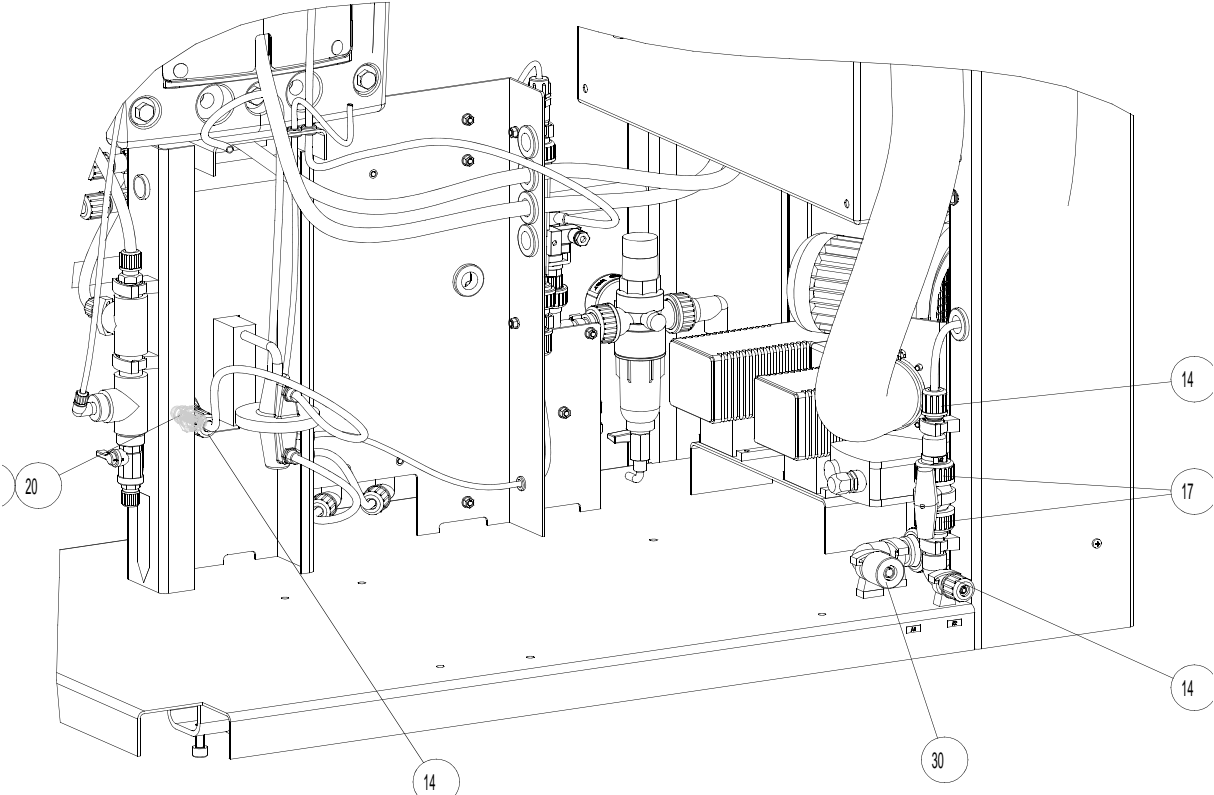

Fig. 2 Wear parts to be replaced

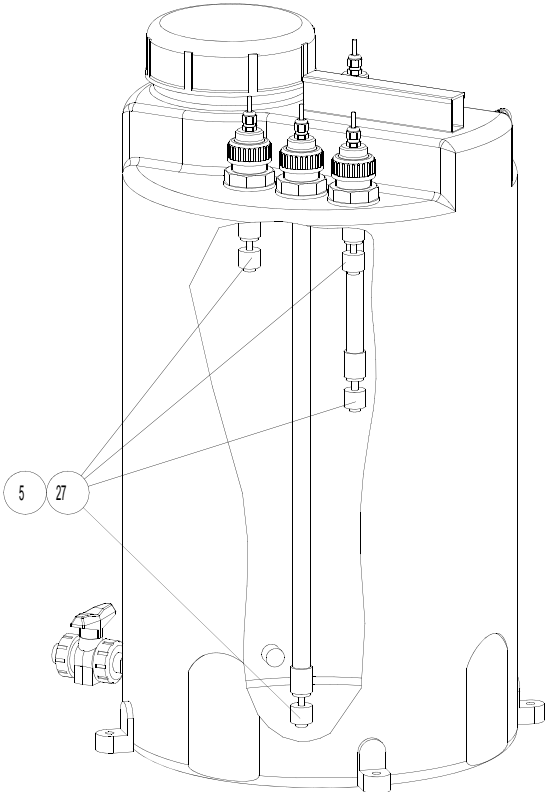

Fig. 3 Wear parts to be replaced

6.3.9 Brine pump maintenance



Please note

The brine pump has a two year maintenance interval. The pump head service set is included in the maintenance parts set for 2 years. The prescribed maintenance schedule is given in the table in chapter 6.2.5 Using the maintenance part sets.

The chlorine membrane electrolysis system is drained and rinsed and switched off at the main switch.

Proceed as follows:



Warning!

Risk of injury!

Chlorine gas is toxic when inhaled and may cause loss of consciousness. The pump maintenance may therefore only be carried out if the anode chamber is empty.

- 1 Perform pump maintenance using the pump head service set. For details, see the pump operating manual.



Please note

Grease all of the replacement o-rings for the brine pump with silicone grease before fitting!

6.3.10 Cleaning the water softener injector

The chlorine membrane electrolysis system is drained and rinsed and switched off at the main switch.

Proceed as follows:

- 1 Release the pipe clamps on the injector line.
- 2 Dismantle the injector line as shown in the drawing.

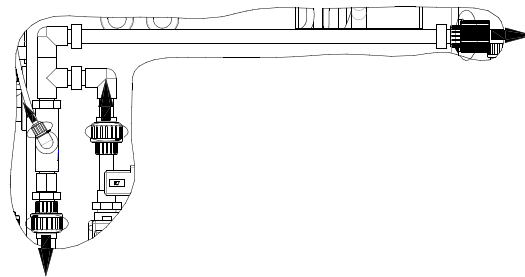

- 3 Remove injector as shown in the drawing.

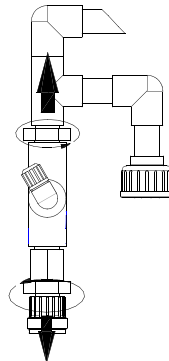

- 4 Check injector for contamination.
- 5 If necessary, dismantle and clean the injector.



Please note

When dismantling the injector, note the sequence of the parts and observe this sequence when reassembling!

- 6 Reassemble the injector and install in the injector line.
- 7 Seal the injector again using Teflon tape.
- 8 Reinstall the entire injector line.
- 9 Tighten the support clamps on the injector line again.

6.3.11 Replacing the hydrogen vent hose on the hydrogen vent pipe

The chlorine membrane electrolysis system is drained and rinsed and switched off at the main switch.

Proceed as follows:

- 1 Cut the new hydrogen vent hose to the required length.
- 2 Release the hose clamps with a screwdriver.
- 3 Pull the hydrogen vent hose off the hydrogen vent pipe and blow-out head.
- 4 Push or twist the hose clamps onto the new hydrogen vent hose.
- 5 Push the hydrogen vent hose onto the hydrogen vent pipe and blow-out head.
- 6 Tighten the hose clamps with a screwdriver.

6.3.12 Replacing the rectifier fan

Drain and rinse the chlorine membrane electrolysis system and switch off at the main switch.

Proceed as follows:

- 1 Prepare the fan.
- 2 Make sure that the chlorine membrane electrolysis system cannot be switched back on at the main switch while the rectifier is being replaced.
- 3 Loosen the air supply duct inside the control cabinet. To this, unscrew the hexagon nuts. The air supply duct cannot be completely removed due to its design.
- 4 Electrically disconnect the fan. Mark the polarity, if necessary.
- 5 Remove the 4 retaining screws from the fan. Fan and fan grill detach from the rectifier.
- 6 Fix the new fan and the existing fan grill to the rectifier using the present retaining screws, ensuring a correct direction of flow (from right to left).
- 7 Electrically connect the fan to the rectifier, ensuring correct polarity.
- 8 Carefully push the air supply duct onto the fan. Fasten the air supply duct to the control cabinet. To this, tighten the hexagon nuts.
- 7 After starting up the system again check the fan is working correctly.

6.3.13 Replacing the rectifier

Spare parts For replacment of the rectifier we provide as a spare part:

Chlorine membrane electrolysis system	Rectifier Part No.
OSEC-NXT 6	W3T349737

The chlorine membrane electrolysis system is drained and rinsed and switched off at the main switch.

Proceed as follows:

- 1 Prepare the rectifier.
- 2 Make sure that the chlorine membrane electrolysis system cannot be switched back on at the main switch while the rectifier is being replaced.
- 3 Open the control cabinet with the control cabinet key.
- 4 Loosen the air supply duct inside the control cabinet. To this, unscrew the hexagon nuts. The air supply duct cannot be completely removed due to its design.
- 5 Unplug the green plug on the rectifier.
- 6 Disconnect the mains cable from the rectifier.
- 7 Mark the polarity of both of the cell cables, then disconnect.
- 8 Unscrew the 4 retaining screws and remove the old rectifier from the system.
- 9 Install the new rectifier in the control cabinet and tighten the 4 retaining screws.
- 10 Reconnect the green plug. The plug is keyed to prevent it being inserted incorrectly. Make sure that the plug is firmly seated.
- 11 Connect the cell cables in accordance with the polarity marking on the terminals on the rectifier output and tighten the terminals. Make sure that contact has been established and that the cables are firmly seated.
- 12 Connect the mains cable to the rectifier.
- 13 Carefully push the air supply duct onto the fan. Fasten the air supply duct to the control cabinet. To this, tighten the hexagon nuts.
- 14 Lock the control cabinet with the control cabinet key again.

6.3.14 Replacing the suction lance



Please note

The suction lance has a 5-year maintenance interval and a replacement is included in the 5-year maintenance set. The prescribed maintenance schedule is given in the table in chapter 6.2.5 Using the maintenance part sets

The chlorine membrane electrolysis system is drained and rinsed and switched off at the main switch.

Proceed as follows:

- 1 Prepare the suction lance.
- 2 Disconnect the old suction lance in the control cabinet.
- 3 Unscrew the union nut from the top of the old suction lance and remove the brine tube.
- 4 Pull the suction lance out of the extraction pipe on the salt dissolving tank, together with the adapter cap.
- 5 Remove the adapter cap from the old suction lance and push it onto the new suction lance.
- 6 Check the float to ensure it has freedom of movement.
- 7 Insert the new suction lance, together with the adapter cap, into the extraction pipe on the salt dissolving tank.
- 8 Screw the union nut onto the new suction lance.
- 9 Connect the new suction lance in the control cabinet as described in chapter 9. Wiring diagram.

6.3.15 Replacing the paddle switch on the air flow monitor

The chlorine membrane electrolysis system is drained and rinsed and switched off at the main switch.

Proceed as follows:

- 1 Prepare the paddle switch.
- 2 Remove the old paddle switch.
- 3 Install the new paddle switch and connect as described in chapter 9. Wiring diagram.
- 4 After the chlorine membrane electrolysis system has been started up again, check that the air flow monitor is functioning correctly. See chapter 4.7.12 Checking the hydrogen vent pipe for details.

6.4 Replacing the electrolysis cell

Spare parts For replacment of the electrolysis cell we provide as a spare part:

Part No.	Designation	System
W3T196820	Spare electrolysis cell	OSEC-NXT 6

Proceed as follows:

The chlorine membrane electrolysis system is in MANUAL mode, operating state "Preparation off".

1 Prepare the following tools:

- Hose 6/8
- Hose 6/8 for connection to a 1/2" screw connection
- Empty sodium hydroxide canister
- Sodium thiosulphate
- 20 l bucket
- Drum pump
- Sodium hydroxide
- Hydrochloric acid

Empty and rinse the anode chamber

2 Empty and rinse the anode chamber. See chapter 6.3.7 for details.

3 Open the chlorine separator outlet (M9) and empty the anode chamber completely.

Empty and rinse the cathode chamber

4 Empty and rinse the cathode chamber. See chapter 6.3.6 for details.

Empty the water from the cathode chamber

5 Connect the cathode-side outlet and the sewage system with a hose.

6 Open the ball valve of the cathode-side outlet (M11) and empty the cathode chamber completely.

Empty the water from the anode chamber

7 Connect the chlorine separator drain (M9) to the sewage system using a hose.

8 Turn off the chlorine membrane electrolysis system at the main switch.



Attention!

Damage to the electrolysis cell!

The following tasks must be performed in quick succession to prevent the cell from drying out!

- 9 Empty the water from the replacement cell.
- 10 Remove the old electrolysis cell from the chlorine membrane electrolysis system.
- 11 Replace the elbow unions from the cathode inlet on both of the electrolysis cells by unscrewing the union nuts on the cell connection to the elbow unions.

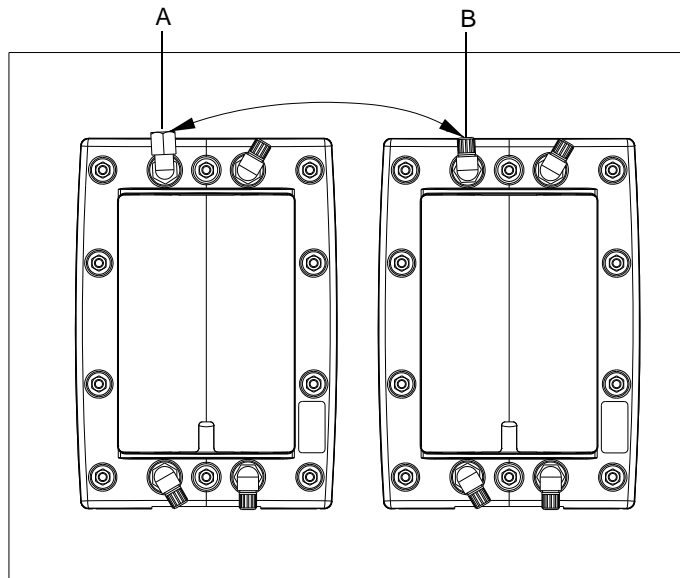

A Old electrolysis cell
B New electrolysis cell

Fill the cathode chamber with sodium hydroxide solution

Rinse the anode chamber with acid

- 12 Replace the electrolysis cell. Ensure the mechanical and electrical connections are connected correctly.
- 13 Using the drum pump, add sodium hydroxide via the cathode-side outlet until it runs out of the sodium hypochlorite pipe into the sodium hypochlorite tank.
- 14 Close the ball valve (M1) on the cathode-side outlet immediately after filling to prevent it flowing back into the canister.
- 15 Connect the chlorine separator drain and the drum pump using a hose.
- 16 Ensure that the chlorine separator outlet (M9) is open.
- 17 Pump 9% hydrochloric acid into the anode chamber using the drum pump until the fill level in the chlorine separator is steady above the top of the electrolysis cell.
- 18 Switch the pump off as soon as the fill level is reached.
- 19 Close the chlorine separator drain (M9) as soon as it has been emptied.
- 20 Rinse the drum pump with approx. 5 l of softened water.

Main screen
MENU
Menu select
Manual functions
Brine filling On
MANUAL FUNCTIONS

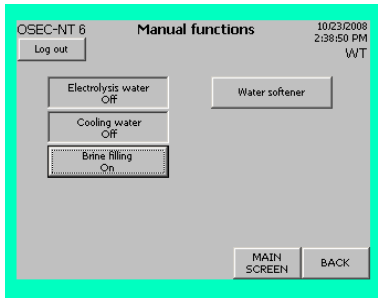

21 Wait 15 minutes and then drain the acid from the anode chamber.

22 Turn on the chlorine membrane electrolysis system at the main switch.

23 Refill the anode chamber with brine again immediately. Switch to the "Manual functions" screen and press the "Brine filling On" button. When the fluid level limit is reached in the chlorine separator the brine pump stops automatically. The manual brine pump function is simultaneously turned off.



Attention!

Damage to the system!

The system must be started immediately (within approx. 1 hour) after being rinsed with acid!

6.5 Shut-down

If the chlorine membrane electrolysis system needs to be shut down for longer than four weeks, it must be shut down by trained and authorized personnel or by Evoqua service personnel.



Attention!

If the system is switched off and disconnected from the power supply for a prolonged period (> 4 h) the electrolysis cells may be permanently damaged.

6.5.1 Summary of the shut-down procedure

Affected parts	Required work	See chapter
System in general	Switch off automatic mode by pressing the "Mode" button.	
	Empty and rinse the anode chamber	6.3.7
	Empty and rinse the cathode chamber.	6.3.6
	Shut-down on the control and display unit	6.5.2
	Turn off the system at the main switch	



Attention!

Damage to the system!

Always perform the steps in the process in the order specified.

6.5.2 Shut-down the system on the control and display unit

The chlorine membrane electrolysis system is empty and rinsed and in MANUAL mode, operating state "Preparation off".

Main screen
MENU
Menu select
Service
Shut-down

SERVICE

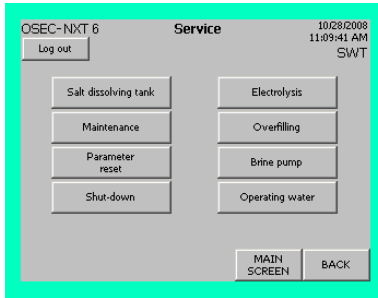

Proceed as follows:

- 1 Switch to the "Service" screen and press the "Shut-down" button. This opens the "Shut system down?" dialog box.



Please note

The "Shut-down" button is shown if the following conditions are met:

- Login level 3, service personnel
- MANUAL mode
- Operating state "Preparation off"

Main screen
MENU
Menu select
Service
Shut-down
System shut-down Yes

SERVICE

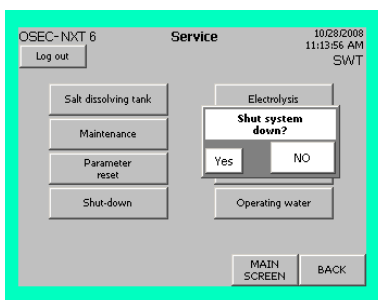

- 2 To confirm that you wish to shut the system down, press "Yes". The display switches to the start-up menu. Now the system can be switched off at the main switch.

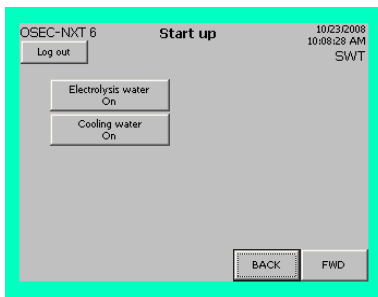

6.6 Starting the system up again

Affected parts	Required work	See chapter
System in general	Ensure the system requirements given in the chapter Start-up are met	4.7
	Turn the system on at the main switch	4.7.5
	Start the system	4.7

7. Dimension drawing

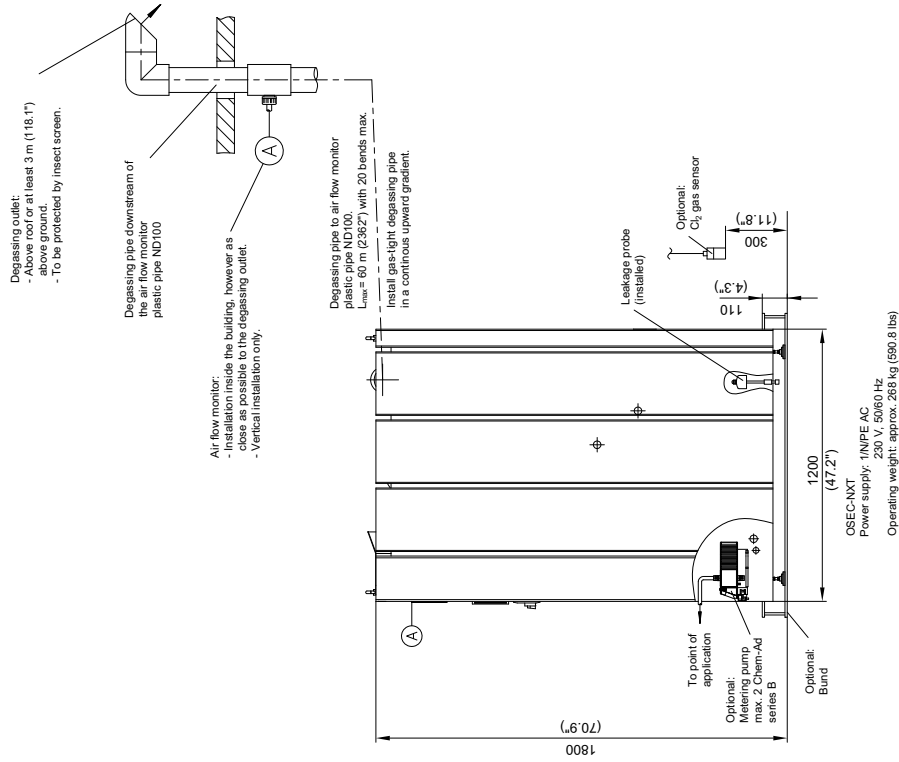

Chlorine Electrolyser Unit
 OSEC-NXT 6

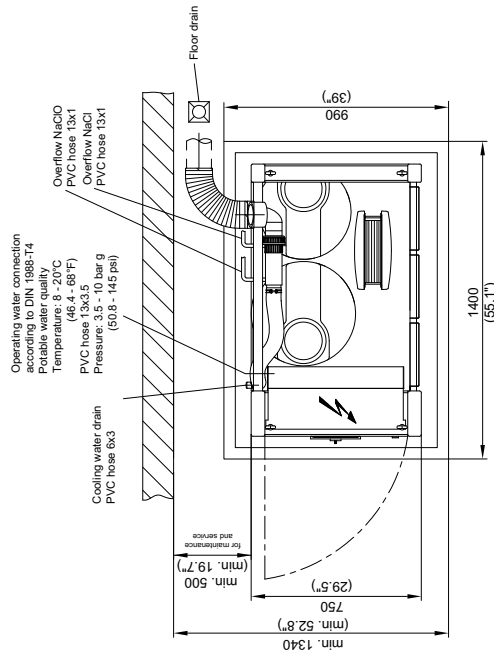

Wallace & Tiernan®
 an EVOQUA brand

Installation
 WT.085.130.020.IE.CN.0916

- | | | | | | | | |
|---|---|--|--|--|--|--|---|
| Australia
+61 3 8720 6587
info.au@evoqua.com | Canada
+1 905 944 2800
canada@evoqua.com | China
+86 10 57076305
sales.cn@evoqua.com | France
+33 1 41 15 92 20
wifra@evoqua.com | Germany
+49 8221 9040
wifger@evoqua.com | Singapore
+65 6630 7165
sales.sg@evoqua.com | UK
+44 1732 771777
info.uk@evoqua.com | USA
+1 566 507 9000
wt.us@evoqua.com |
|---|---|--|--|--|--|--|---|

8. Arrangement of components

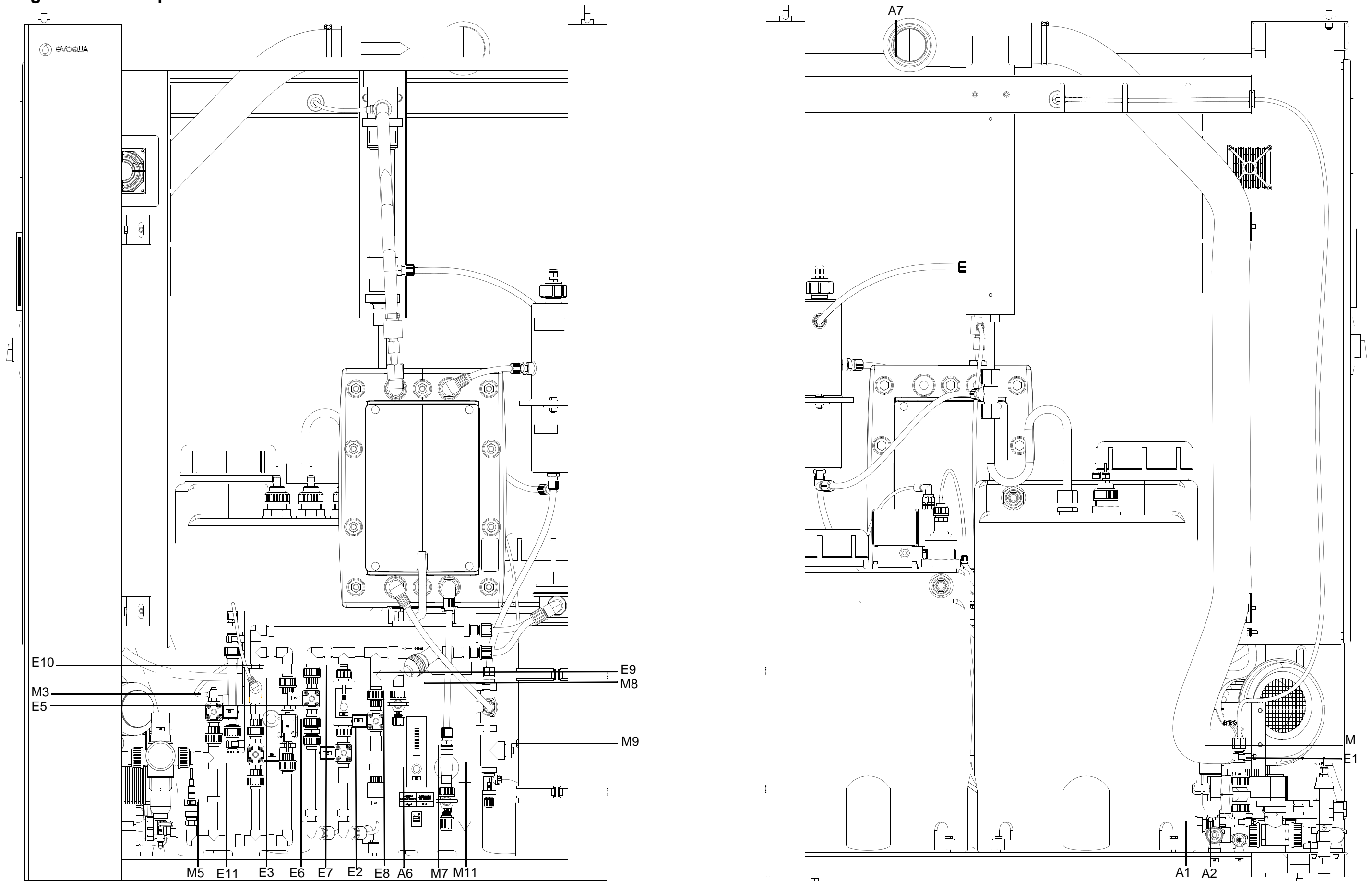





List of components

Group	Label	Designation
Mechanically activated components	M2	Cooling water ball valve
	M3	Operating water pressure reducing valve
	M5	Pressure reducing valve filter drain tap
	M7	Electrolysis water flow meter
	M8	Soft water sample ball valve
	M9	Separator screw-in closable outlet
	M11	Cathode-side ball valve outlet
Electrically activated components	E1	Water inlet ball valve with motor drive
	E2	Electrolysis water solenoid valve
	E3	Cooling water solenoid valve
	E5	Water softener water inlet solenoid valve
	E6	Water softener injector solenoid valve
	E7	Salt dissolving tank filling solenoid valve
	E8	Water softener rinsing solenoid valve
	E9	Electrolysis water flow meter
	E10	Softener brine inlet limit value sensor
	E11	Pressure sensor
Hose connections	A1	Operating water inlet
	A2	Cooling water outlet
	A6	Water softener rinsing outlet
	A7	Hydrogen exhaust pipe



Contents																																	
Sheet	Description	Issue	Date	Document type																													
1	Cover page	7	04.03.20	Cover page																													
4	Cable list internal / external	7	04.03.20	Cable list																													
5	Cable list internal / external	7	04.03.20	Cable list																													
6	Design control panel	7	04.03.20	Design control panel																													
7	List of the signs	7	04.03.20	List of the signs																													
8	free sheet	7	04.03.20	wiring diagram																													
9	PLC	7	04.03.20	wiring diagram																													
10	free sheet	7	04.03.20	wiring diagram																													
11	Main power supply	7	04.03.20	wiring diagram																													
12	DC24V power supply	7	04.03.20	wiring diagram																													
13	PLC	7	04.03.20	wiring diagram																													
14	option Chlorine gas leak detector	7	04.03.20	wiring diagram																													
15	Automatic stopcock Operating water	7	04.03.20	wiring diagram																													
16	Signal relay	7	04.03.20	wiring diagram																													
17	DC-power-supply	7	04.03.20	wiring diagram																													
18	Water softener option external Water softener	7	04.03.20	wiring diagram																													
19	Brine tank	7	04.03.20	wiring diagram																													
20	Storage tank	7	04.03.20	wiring diagram																													
21	Leakage monitoring	7	04.03.20	wiring diagram																													
22	Fan Air flow monitor	7	04.03.20	wiring diagram																													
23	Brine pump chlor separator	7	04.03.20	wiring diagram																													
24	Elektrolysis water Cooling water	7	04.03.20	wiring diagram																													
25	option Dosing pump 1/2	7	04.03.20	wiring diagram																													
26	release Preparation release Plant	7	04.03.20	wiring diagram																													
27	Message interface	7	04.03.20	wiring diagram																													
28	free sheet	7	04.03.20	wiring diagram																													
<table border="1"> <tr> <td colspan="2">  </td> <td colspan="2"> Original Ref. / Ref. by </td> </tr> <tr> <td colspan="2"> Date Name Norm </td> <td colspan="2"> Checked release </td> </tr> <tr> <td colspan="2"> Date Drawn Date </td> <td colspan="2"> Design Center / GBR </td> </tr> <tr> <td colspan="2"> 13.06.14 13.01.16 04.03.20 </td> <td colspan="2"> 12.08.08 GBR </td> </tr> <tr> <td colspan="2"> LAE5900 LAE5948 LAE7423 </td> <td colspan="2"> Proc. / Sales </td> </tr> <tr> <td colspan="2"> Issue Revision </td> <td colspan="2"> Date Name Norm </td> </tr> </table>							Original Ref. / Ref. by		Date Name Norm		Checked release		Date Drawn Date		Design Center / GBR		13.06.14 13.01.16 04.03.20		12.08.08 GBR		LAE5900 LAE5948 LAE7423		Proc. / Sales		Issue Revision		Date Name Norm		Contents				
		Original Ref. / Ref. by																															
Date Name Norm		Checked release																															
Date Drawn Date		Design Center / GBR																															
13.06.14 13.01.16 04.03.20		12.08.08 GBR																															
LAE5900 LAE5948 LAE7423		Proc. / Sales																															
Issue Revision		Date Name Norm																															
Project OSEC-NXT order number					Drawing number WAE7158																												
=A1 +S1					Sheet 2 of 33 Pa.																												

Plant: =A1 Place: +S1										
Cable no.	Cable type	Voltage	Length	from	Designation	to	Designation	Cross reference	Remark	
-W028	L1YY-3X0.34	DC 24V	0 mm	=A1+S1-15B7	Chlor-electrolyser	=A1x+S1-X3	Pressure sensor Operating water	=A1+S1/21E4	internal	
-W030	L1YY-4X0.22-LANG	DC 24V	0 mm	=A1+S1-19B2	Level switch Brine tank	=A1x+S1-X3	Chlor-electrolyser	=A1+S1/19E2	internal	
-W101	NYY-J-3x2.5	AC 230V	0 mm	=A1x+S1-X1	Chlor-electrolyser	energier* empassung_X empassung	Low-voltage distribution	=A1+S1/11E1	to be provided locally, Main power supply	
-W102	NYSLYÖ-J-4x1.0	AC 230V	0 mm	=A1x+S1-X1	Chlor-electrolyser	=A1+S1	Chlorine gas leak detector	=A1+S1/14E2	to be provided locally, Chlorine gas leak	
-W103	NYSLYÖ-J-5x1.0	DC 24V	0 mm	=A1x+S1-X3	Chlor-electrolyser	=A1+S1	ext. Water softener	=A1+S1/18E7	to be provided locally, ext. Water softener	
-W106	L1YY-2X0.22	DC 24V	0 mm	=A1+S1	Leakage monitoring	=A1+S1	Storage tank		to be provided locally, Storage tank	
-W107	L1YY-2X0.22	DC 24V	0 mm	=A1+S1	Leakage monitoring	=A1x+S1-X3	Chlor-electrolyser	=A1+S1/21E4	to be provided locally, Dosage range	
-W108	L1YY-2X0.22	DC 24V	0 mm	=A1+S1-2ZB7	Air flow monitor	=A1x+S1-X3	Chlor-electrolyser	=A1+S1/22E7	to be provided locally, Air flow monitor	
-W113	NYSLYÖ-J-3x0.75	DC 24V	0 mm	=A1x+S1-X3	Chlor-electrolyser	=A1+S1	control room	=A1+S1/26E2	to be provided locally, release Preparation	
-W114	NYSLYÖ-J-3x0.75	DC 24V	0 mm	=A1x+S1-X3	Chlor-electrolyser	=A1+S1	control room	=A1+S1/26E4	to be provided locally, Remote shutdown	
-W115	NYSLYÖ-J-4x1.0	DC 24V	0 mm	=A1+S1-2ZH1	control room	=A1x+S1-X5	Chlor-electrolyser	=A1+S1/27E1	to be provided locally, FlashHorn combir	
-W116	NYSLYÖ-J-18x1.0	0 mm	0 mm	=A1+S1- wert-X, Alltechnik	control room	=A1x+S1-X5	Chlor-electrolyser	=A1+S1/27E3	to be provided locally, Message interface	
-W130	NYSLYÖ-J-3x1.0	AC 230V	0 mm	=A1+S1	Chlor-electrolyser	=A1+S1	Dosing pump		to be provided locally, Dosing pump	
-W131	NYSLYÖ-J-3x1.0	AC 230V	0 mm	=A1+S1	Chlor-electrolyser	=A1+S1	Dosing pump		to be provided locally, Dosing pump 2	
-W132	L1YY-2X0.22	DC 5V	0 mm	=A1+S1	Chlor-electrolyser	=A1+S1	Dosing pump		to be provided locally, Dosing pump 1	
-W133	L1YY-2X0.22	DC 5V	0 mm	=A1+S1	Chlor-electrolyser	=A1+S1	Dosing pump		to be provided locally, Dosing pump 2	
E										
F										
5	LAE5900	13.06.14	rb	Date	12.08.08	GER	Design Center			
6	LAE5948	13.01.16	rb	Drawn	rb		Prof./Sales			
7	LAE7423	04.02.20	rb	Date			release			
Issue	Revision	Date	Name	Checked	Norm					
evoQUA <small>Evolut Water Technologies GmbH</small>								Project order number		=A1 +S1
Cable list internal / external								Drawing number		WAE7158
Original								Repl. by		33
Repl. by								Pa.		8

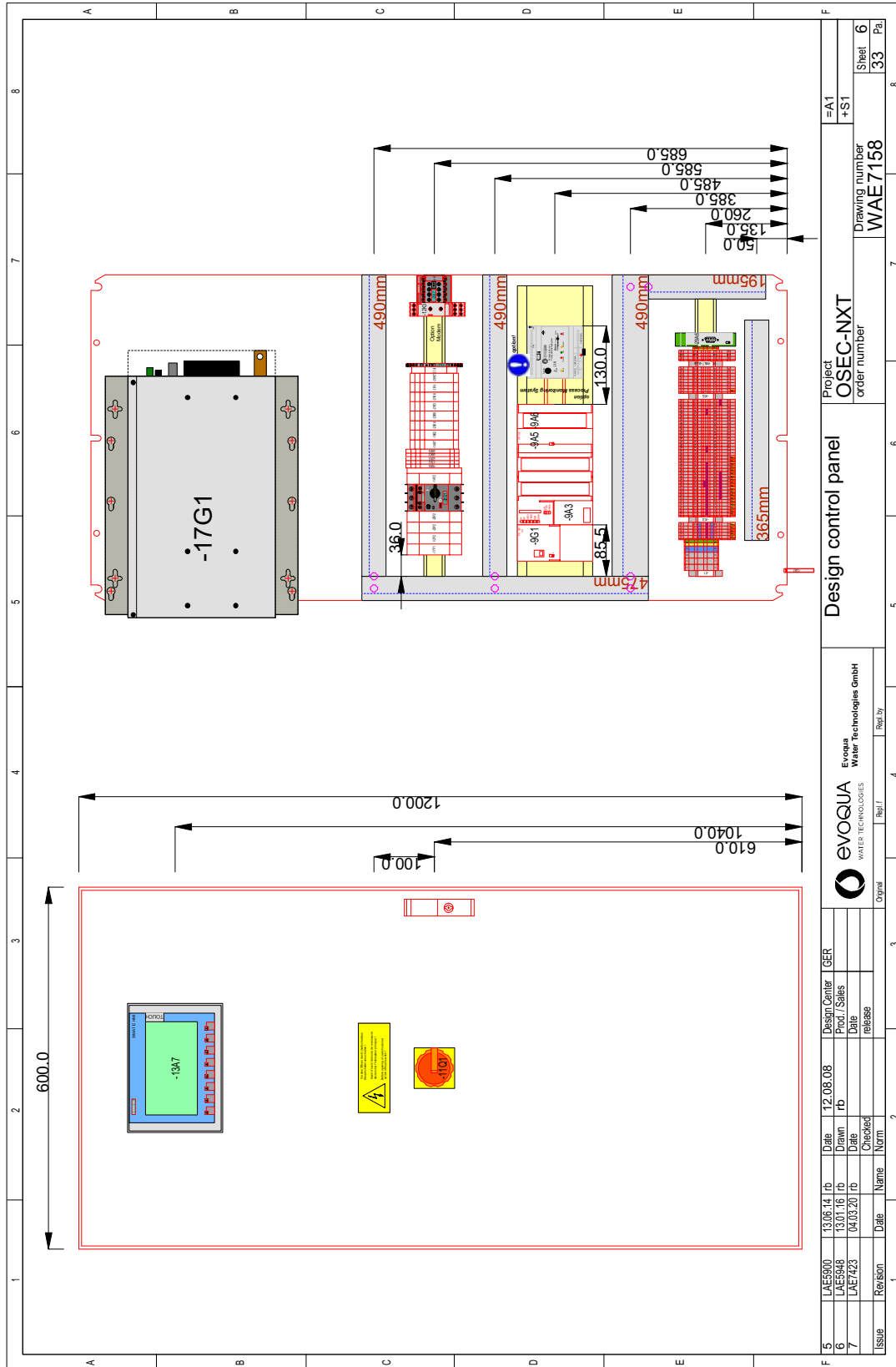

1		2		3		4		5		6		7		8																																																																									
A															F																																																																								
B															F																																																																								
C															F																																																																								
D															F																																																																								
E															F																																																																								
<p>List of the signs</p> <p style="text-align: center; font-size: 2em;">This page is left free intentionally</p>															F																																																																								
<p>Material: dimensions: Basis: Font: Height of Font:</p>															F																																																																								
<table border="1"> <thead> <tr> <th>Issue</th> <th>Revision</th> <th>Date</th> <th>Name</th> <th>Date</th> <th>Drawn</th> <th>Checke</th> <th>Norm</th> <th>Date</th> <th>Design Center</th> <th>GER</th> <th>Prod./Sales</th> <th>release</th> <th>Project</th> <th>Order number</th> <th>Drawing number</th> <th>Sheet</th> <th>Pa.</th> </tr> </thead> <tbody> <tr> <td>5</td> <td>LAE5900</td> <td>13.06.14</td> <td>rb</td> <td>12.08.08</td> <td>rb</td> <td></td> <td></td> <td></td> <td></td> <td></td> <td></td> <td></td> <td>OSEC-NXT</td> <td>WAE7158</td> <td>7</td> <td>33</td> <td></td> </tr> <tr> <td>6</td> <td>LAE5948</td> <td>13.01.16</td> <td>rb</td> <td></td> <td></td> <td></td> <td></td> <td></td> <td></td> <td></td> <td></td> <td></td> <td></td> <td></td> <td></td> <td></td> <td></td> </tr> <tr> <td>7</td> <td>LAE7423</td> <td>04.02.20</td> <td>rb</td> <td></td> <td></td> <td></td> <td></td> <td></td> <td></td> <td></td> <td></td> <td></td> <td></td> <td></td> <td></td> <td></td> <td></td> </tr> </tbody> </table>															Issue	Revision	Date	Name	Date	Drawn	Checke	Norm	Date	Design Center	GER	Prod./Sales	release	Project	Order number	Drawing number	Sheet	Pa.	5	LAE5900	13.06.14	rb	12.08.08	rb								OSEC-NXT	WAE7158	7	33		6	LAE5948	13.01.16	rb															7	LAE7423	04.02.20	rb															F
Issue	Revision	Date	Name	Date	Drawn	Checke	Norm	Date	Design Center	GER	Prod./Sales	release	Project	Order number	Drawing number	Sheet	Pa.																																																																						
5	LAE5900	13.06.14	rb	12.08.08	rb								OSEC-NXT	WAE7158	7	33																																																																							
6	LAE5948	13.01.16	rb																																																																																				
7	LAE7423	04.02.20	rb																																																																																				
<p>List of the signs</p>															F																																																																								
<p>evoQUA WATER TECHNOLOGIES Evopot Water Technologies GmbH</p>															F																																																																								
<p>Original</p>															F																																																																								
<p>Rep./I</p>															F																																																																								
<p>Rep./II</p>															F																																																																								
<p>Rep./by</p>															F																																																																								

This page is left
free intentionally

1	2	3	4	5	6	7	8
A	B	C	D	E	F		
5	6	7			Project	=A1	8
LAE800	13.06.14	12.08.08	GER	free sheet		+S1	33
LAE848	13.01.16	rd	Design Center	order number		Drawing number	Pa
LAE7423	04.03.20	rd	Prod./Sales	WAE7158		WAE7158	8
Revision	Date	Name	release				
Issue	Date	Name	release				
			Original	Repl. I	Repl. II	Repl. III	Repl. IV
			 eVOQUA WATER TECHNOLOGIES		EVOQUA WATER TECHNOLOGIES GmbH		

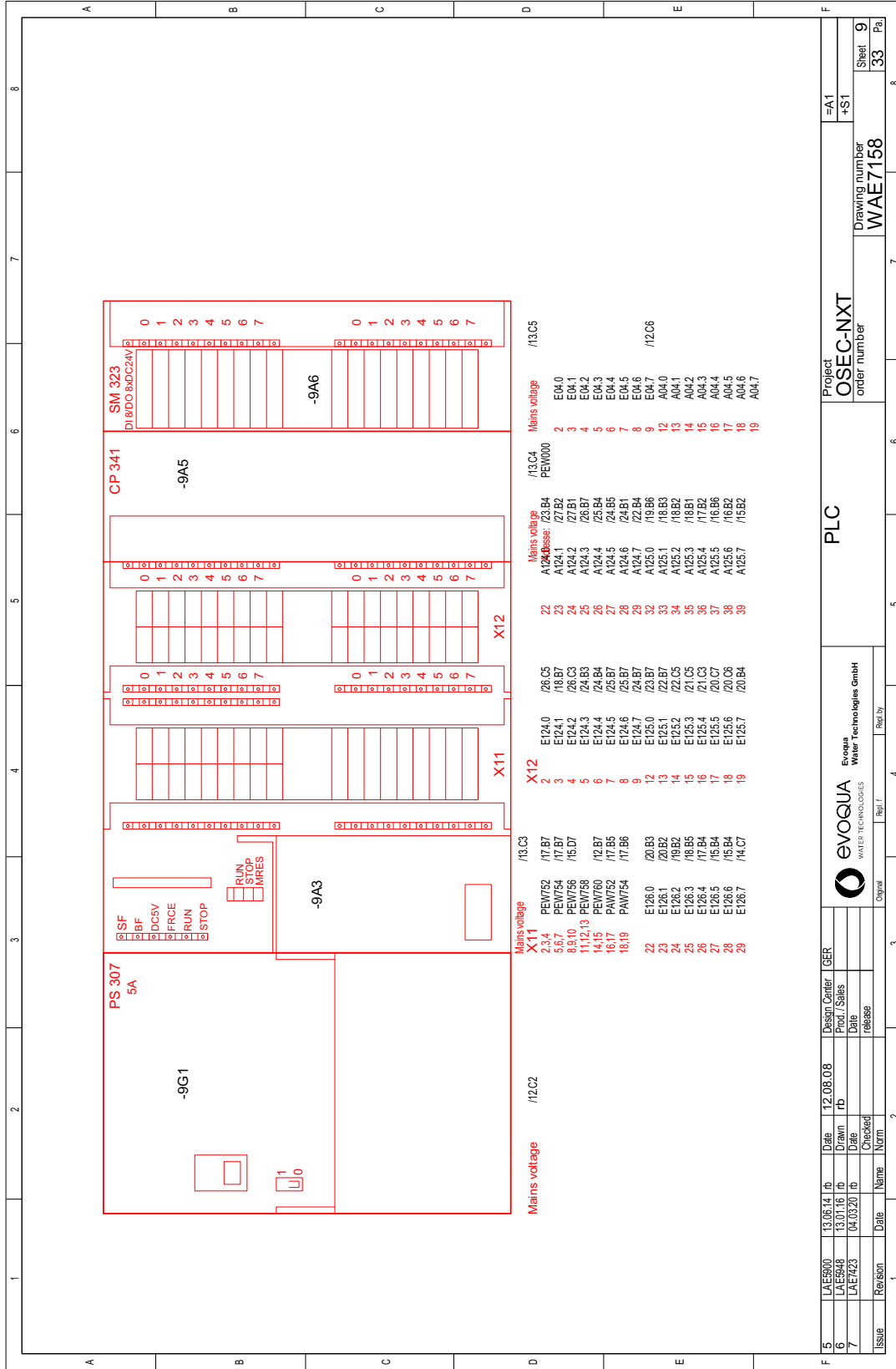

5	LAE800	13.06.14	th	Date	12.08.08	GER	Design Center		Project	OSEC-NXT	order number	WAE7158	Sheet	9	Pa.	33
6	LAE848	13.01.16	th	Drawn	rd		Prod./Sales		Project	OSEC-NXT	order number	WAE7158	Sheet	9	Pa.	33
7	LAE7423	04.03.20	th	Date			release		Project	OSEC-NXT	order number	WAE7158	Sheet	9	Pa.	33
Issue	Revision	Date	Name	Norm					Project	OSEC-NXT	order number	WAE7158	Sheet	9	Pa.	33

This page is left
free intentionally

1	2	3	4	5	6	7	8
A	B	C	D	E	F		
5	6	7			Project	=A1	8
LAE800	13.06.14	12.08.08	GER	free sheet		+S1	9
LAE848	13.01.16	rd	Design Center	Project		Drawing number	10
LAE7423	04.03.20	rd	Prod./Sales	order number		WAE7158	11
Revision	Date	Name	release			Pa.	12
Issue	Date	Name	release			Pa.	13
1	2	3	4	5	6	7	8
A	B	C	D	E	F		



eVOQUA
WATER TECHNOLOGIES

Evonik
Water Technologies GmbH

Original

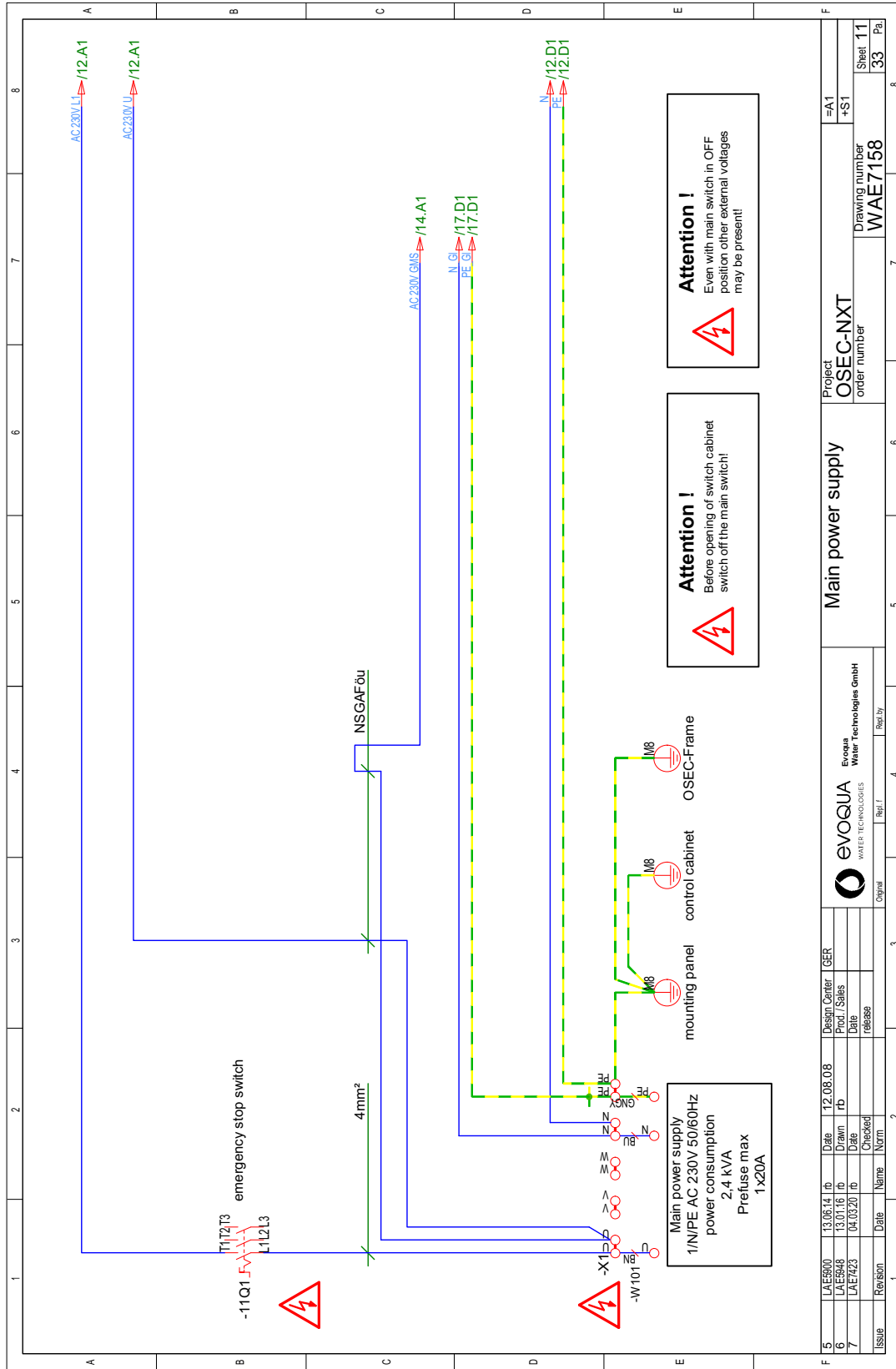

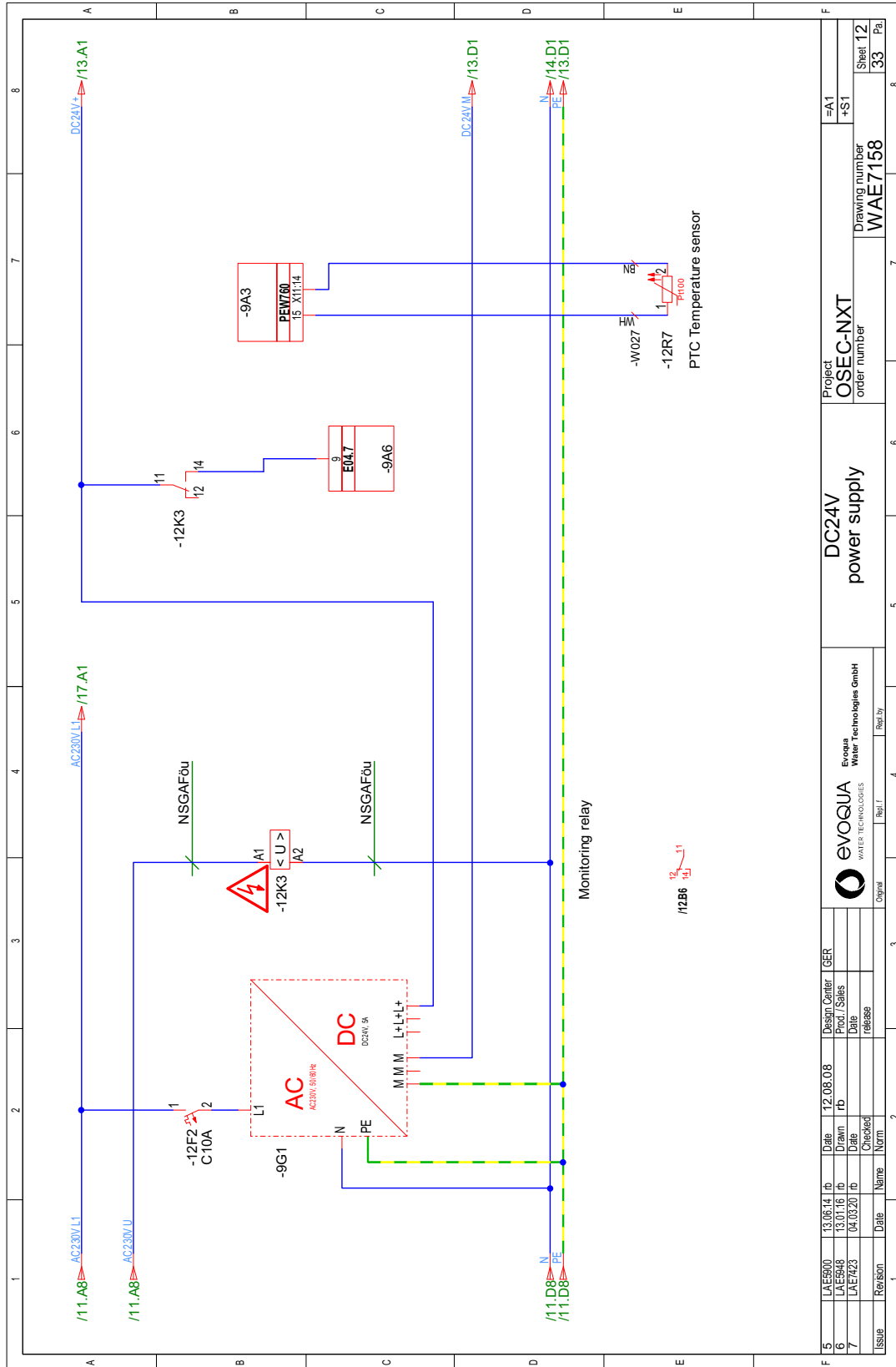

5	LAE800	13.06.14	ib	Date	12.08.08	GER	Design Center	Project	OSEC-NXT	order number	WAE7158	Sheet 12	33	Pa.
6	LAE848	13.01.16	ib	Drawn	rd		Prod./Sales	DC24V	power supply	Drawing number	WAE7158			
7	LAE7423	04.03.20	ib	Date			release							
	Revision	Date	Name	Norm	Checked									

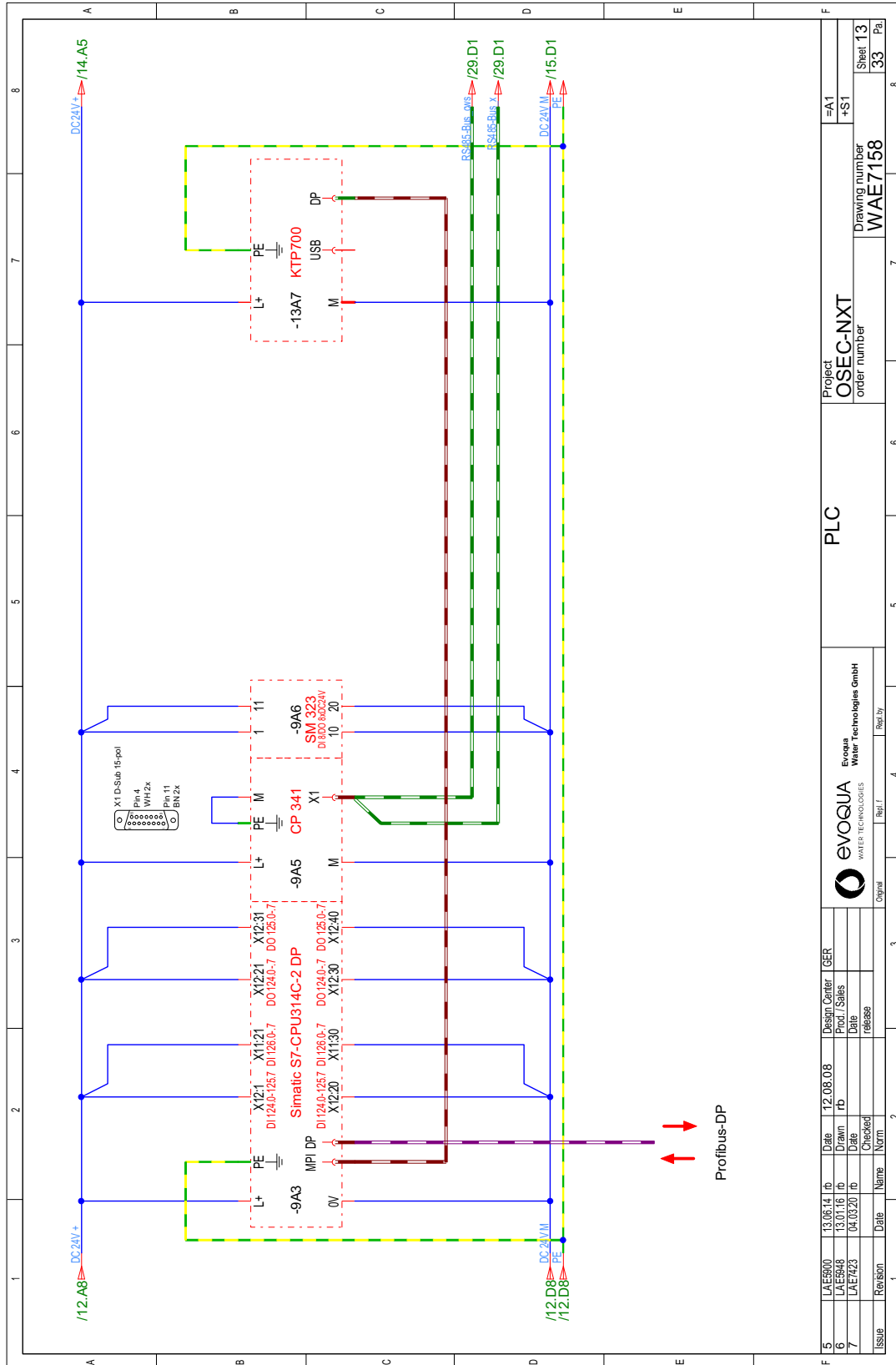

5	LAE800	13.06.14	ib	Date	12.08.08	GER	Design Center		Project	OSEC-NXT	order number		Sheet 13
6	LAE848	13.01.16	ib	Drawn	rd		Prod./Sales		PLC		Drawing number	WAE7158	33
7	LAE7423	04.03.20	ib	Date		release							Pa.
Issue	Revision	Date	Name	Norm			Original	Repl. I	Repl. J	Read by			
					2	3							6

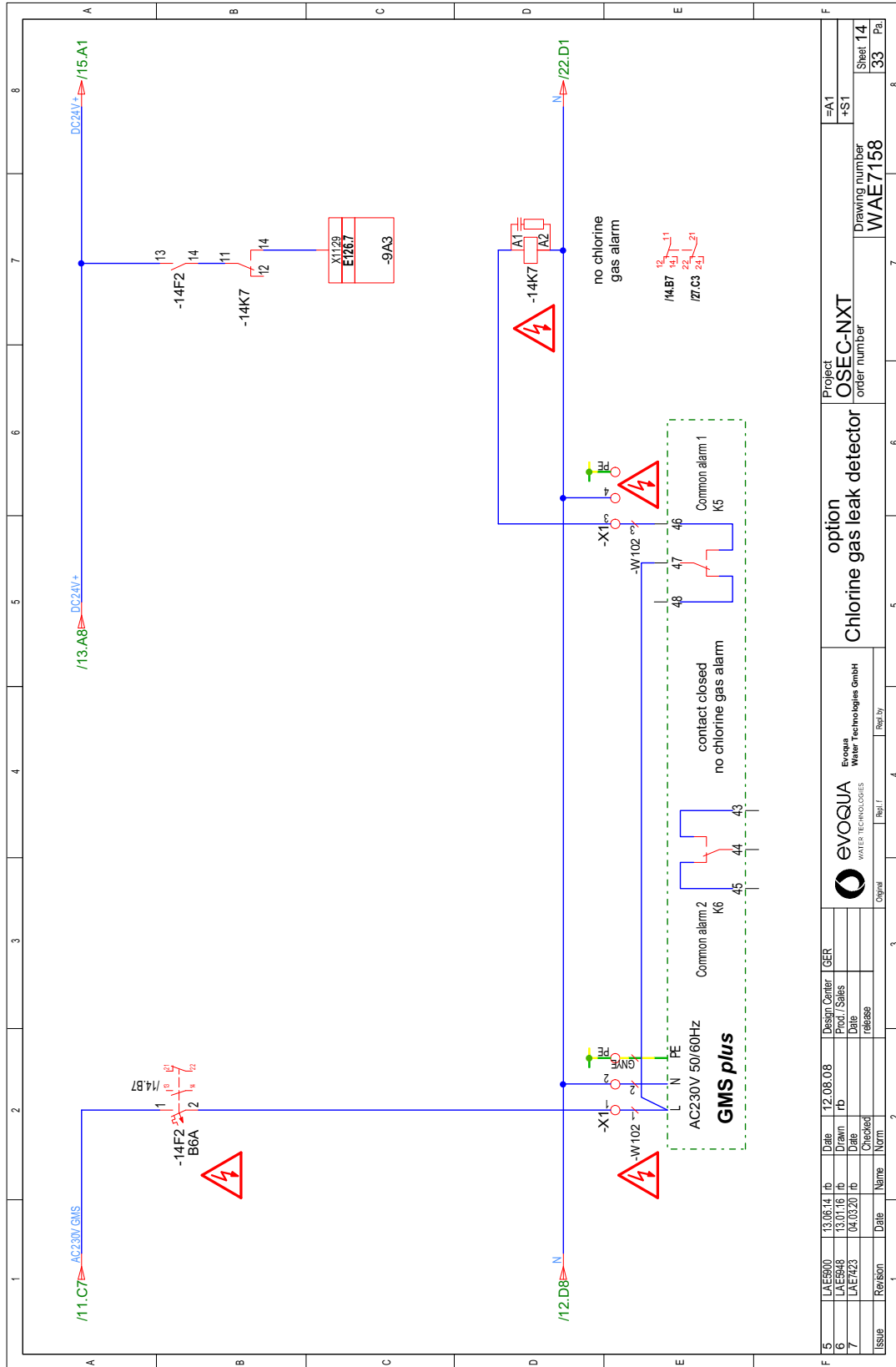

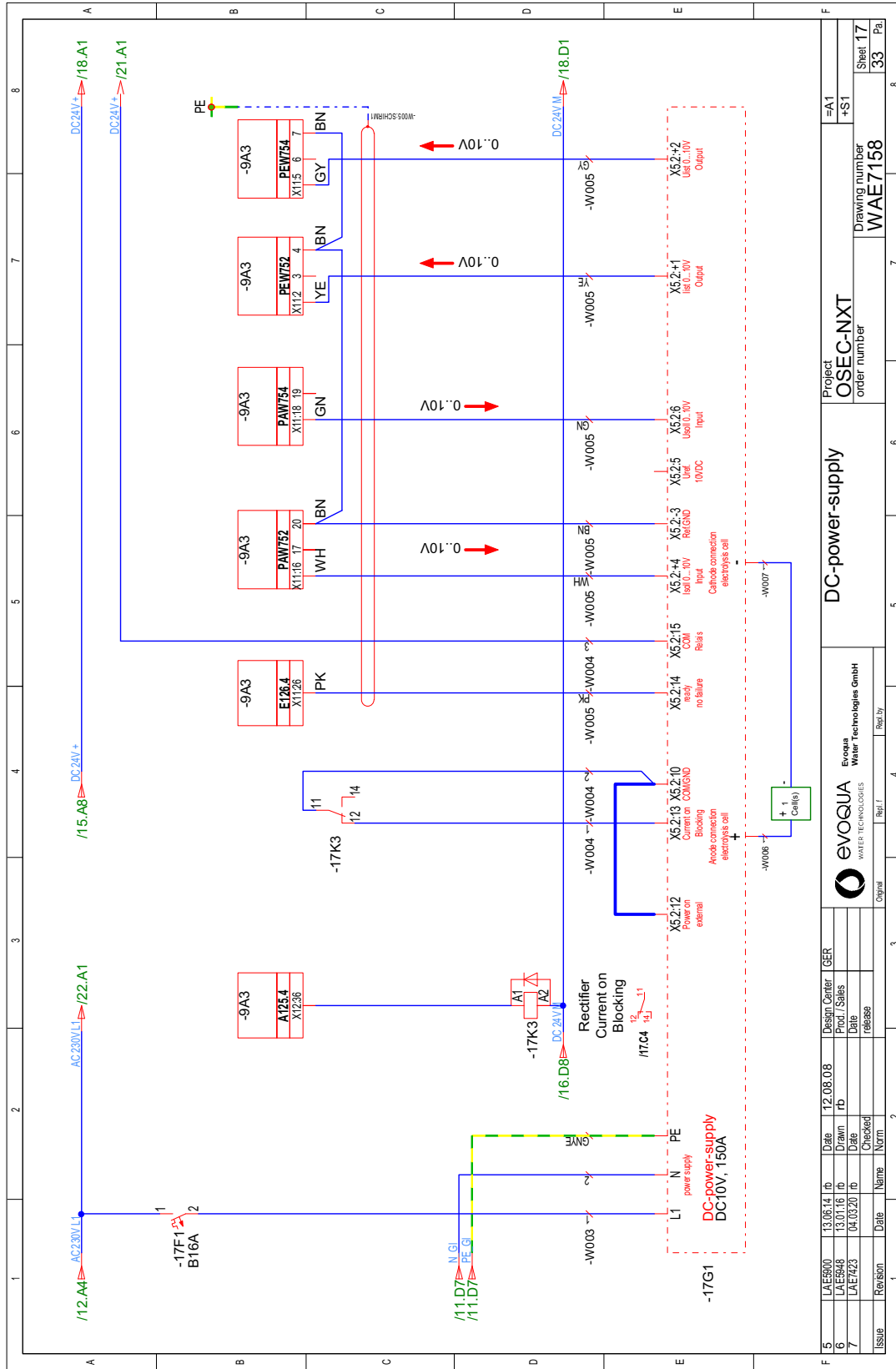

Issue	Revision	Date	Name	Norm	Checked	Date	Drawn	Date	Design Center	GER
5		13.06.14	fb						12.08.08	
6		13.01.16	fb							
7		04.03.20	fb							

Original	Repl. I	Repl. II	Repl. III
----------	---------	----------	-----------

		Evoqua Water Technologies GmbH	
DC-power-supply			
Project order number		WAE7158	
Drawing number		WAE7158	
Sheet 17		33	
Pa.		6	

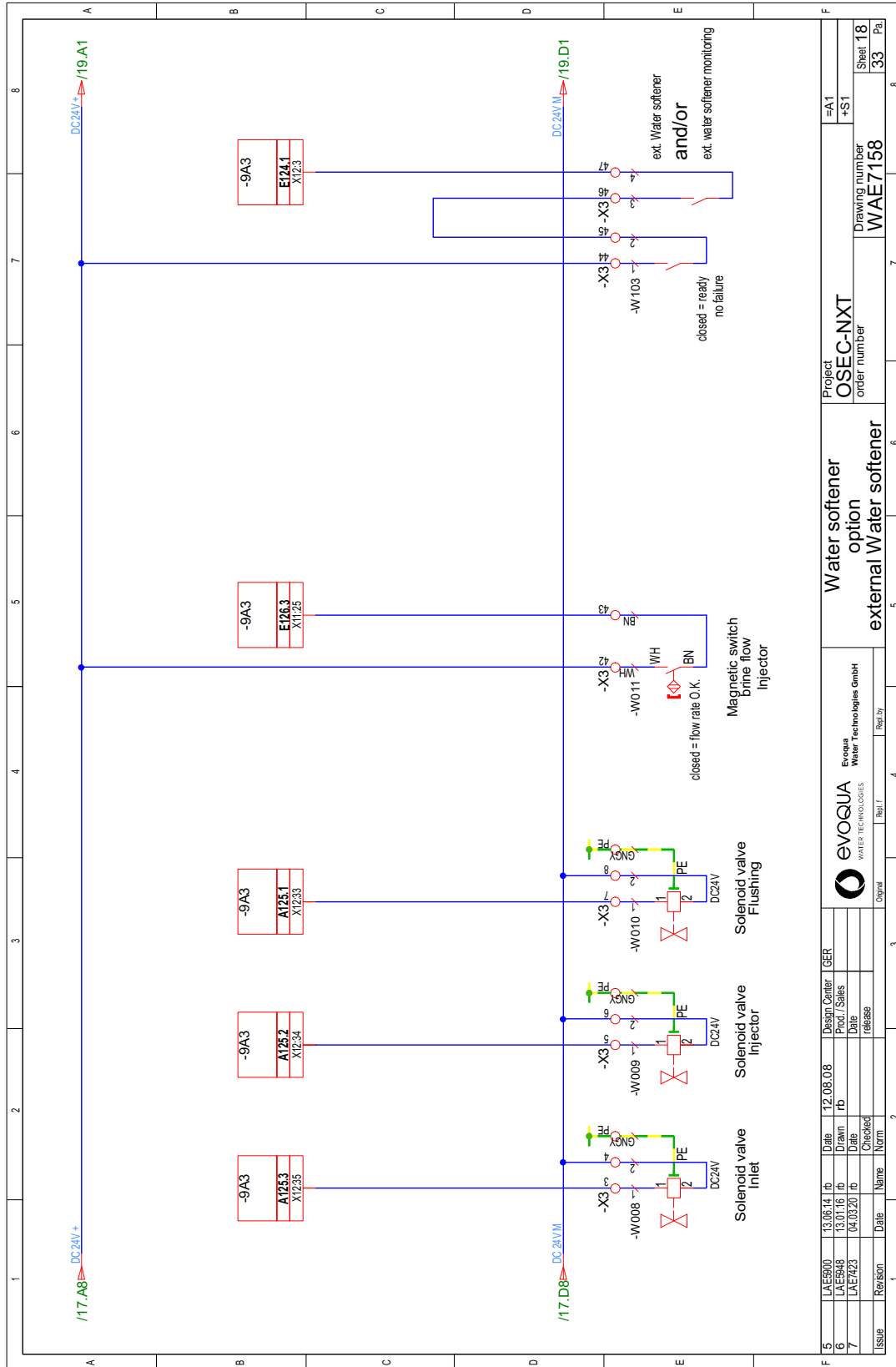

Issue		Revision		Date		Name		Norm		Checked		Date		Drawn		Date		Prod./States		Design Center		GER																							
5		LA/E800		13.06.14	rb																																								
6		LA/E848		13.01.16	rb																																								
7		LA/E7423		04.03.20	rb																																								
<table border="0" style="width:100%; border-collapse: collapse;"> <tr> <td style="width: 20%;"></td> <td style="width: 20%; text-align: center;">Original</td> <td style="width: 20%; text-align: center;">Repl. I</td> <td style="width: 20%; text-align: center;">Repl. II</td> <td style="width: 20%; text-align: center;">Repl. III</td> <td style="width: 20%; text-align: center;">Repl. IV</td> <td style="width: 20%; text-align: center;">Repl. V</td> <td style="width: 20%; text-align: center;">Repl. VI</td> <td style="width: 20%; text-align: center;">Repl. VII</td> <td style="width: 20%; text-align: center;">Repl. VIII</td> <td style="width: 20%; text-align: center;">Repl. IX</td> <td style="width: 20%; text-align: center;">Repl. X</td> <td style="width: 20%; text-align: center;">Repl. XI</td> <td style="width: 20%; text-align: center;">Repl. XII</td> <td style="width: 20%; text-align: center;">Repl. XIII</td> <td style="width: 20%; text-align: center;">Repl. XIV</td> <td style="width: 20%; text-align: center;">Repl. XV</td> <td style="width: 20%; text-align: center;">Repl. XVI</td> <td style="width: 20%; text-align: center;">Repl. XVII</td> <td style="width: 20%; text-align: center;">Repl. XVIII</td> <td style="width: 20%; text-align: center;">Repl. XIX</td> <td style="width: 20%; text-align: center;">Repl. XX</td> <td style="width: 20%; text-align: center;">Repl. XXI</td> <td style="width: 20%; text-align: center;">Repl. XXII</td> </tr> </table>																							Original	Repl. I	Repl. II	Repl. III	Repl. IV	Repl. V	Repl. VI	Repl. VII	Repl. VIII	Repl. IX	Repl. X	Repl. XI	Repl. XII	Repl. XIII	Repl. XIV	Repl. XV	Repl. XVI	Repl. XVII	Repl. XVIII	Repl. XIX	Repl. XX	Repl. XXI	Repl. XXII
	Original	Repl. I	Repl. II	Repl. III	Repl. IV	Repl. V	Repl. VI	Repl. VII	Repl. VIII	Repl. IX	Repl. X	Repl. XI	Repl. XII	Repl. XIII	Repl. XIV	Repl. XV	Repl. XVI	Repl. XVII	Repl. XVIII	Repl. XIX	Repl. XX	Repl. XXI	Repl. XXII																						
<table border="0" style="width:100%; border-collapse: collapse;"> <tr> <td style="width: 50%; text-align: center;"> evoQUA <small>WATER TECHNOLOGIES</small> </td> <td style="width: 50%; text-align: center;"> External <small>Water Technologies GmbH</small> </td> </tr> </table>												evoQUA <small>WATER TECHNOLOGIES</small>	External <small>Water Technologies GmbH</small>	<table border="0" style="width:100%; border-collapse: collapse;"> <tr> <td style="width: 50%; text-align: center;"> Water softener option </td> <td style="width: 50%; text-align: center;"> Project OSEC-NXT </td> </tr> <tr> <td style="width: 50%; text-align: center;"> external Water softener </td> <td style="width: 50%; text-align: center;"> order number WAE7158 </td> </tr> </table>												Water softener option	Project OSEC-NXT	external Water softener	order number WAE7158																
evoQUA <small>WATER TECHNOLOGIES</small>	External <small>Water Technologies GmbH</small>																																												
Water softener option	Project OSEC-NXT																																												
external Water softener	order number WAE7158																																												
												<table border="0" style="width:100%; border-collapse: collapse;"> <tr> <td style="width: 50%;"></td> <td style="width: 50%; text-align: center;"> Drawing number WAE7158 </td> </tr> <tr> <td style="width: 50%;"></td> <td style="width: 50%; text-align: center;"> Sheet 18 33 </td> </tr> </table>													Drawing number WAE7158		Sheet 18 33																		
	Drawing number WAE7158																																												
	Sheet 18 33																																												

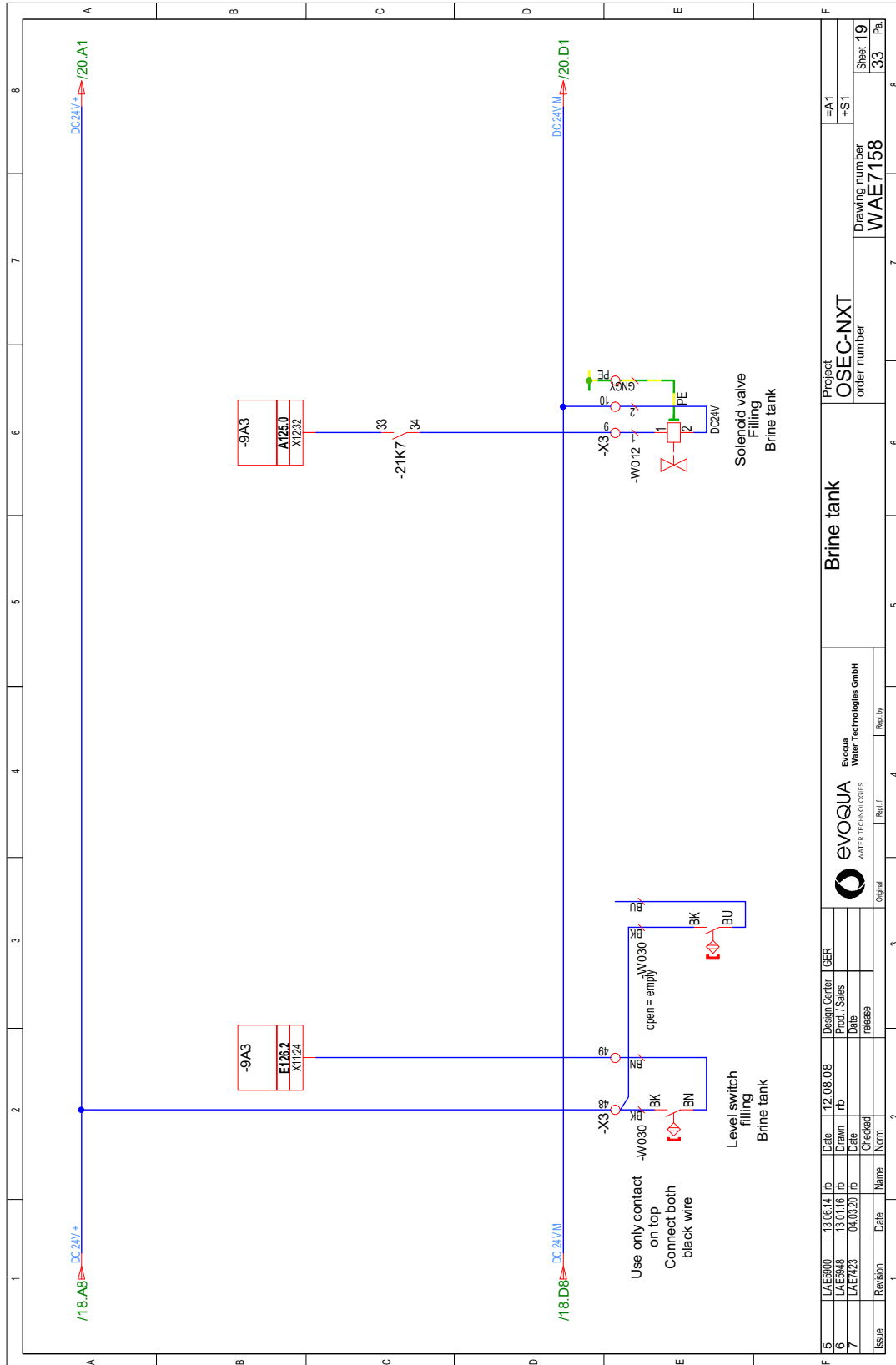

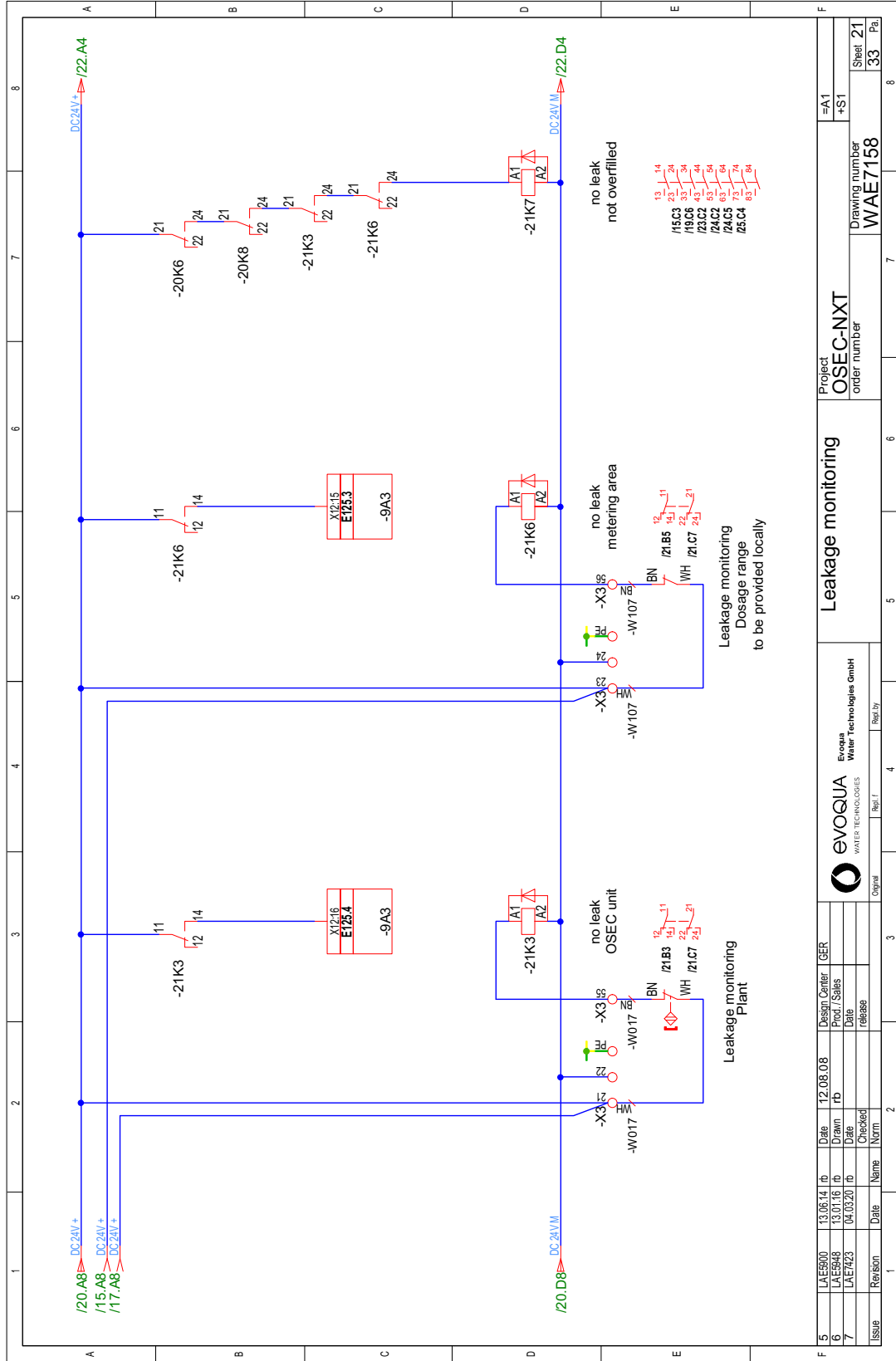

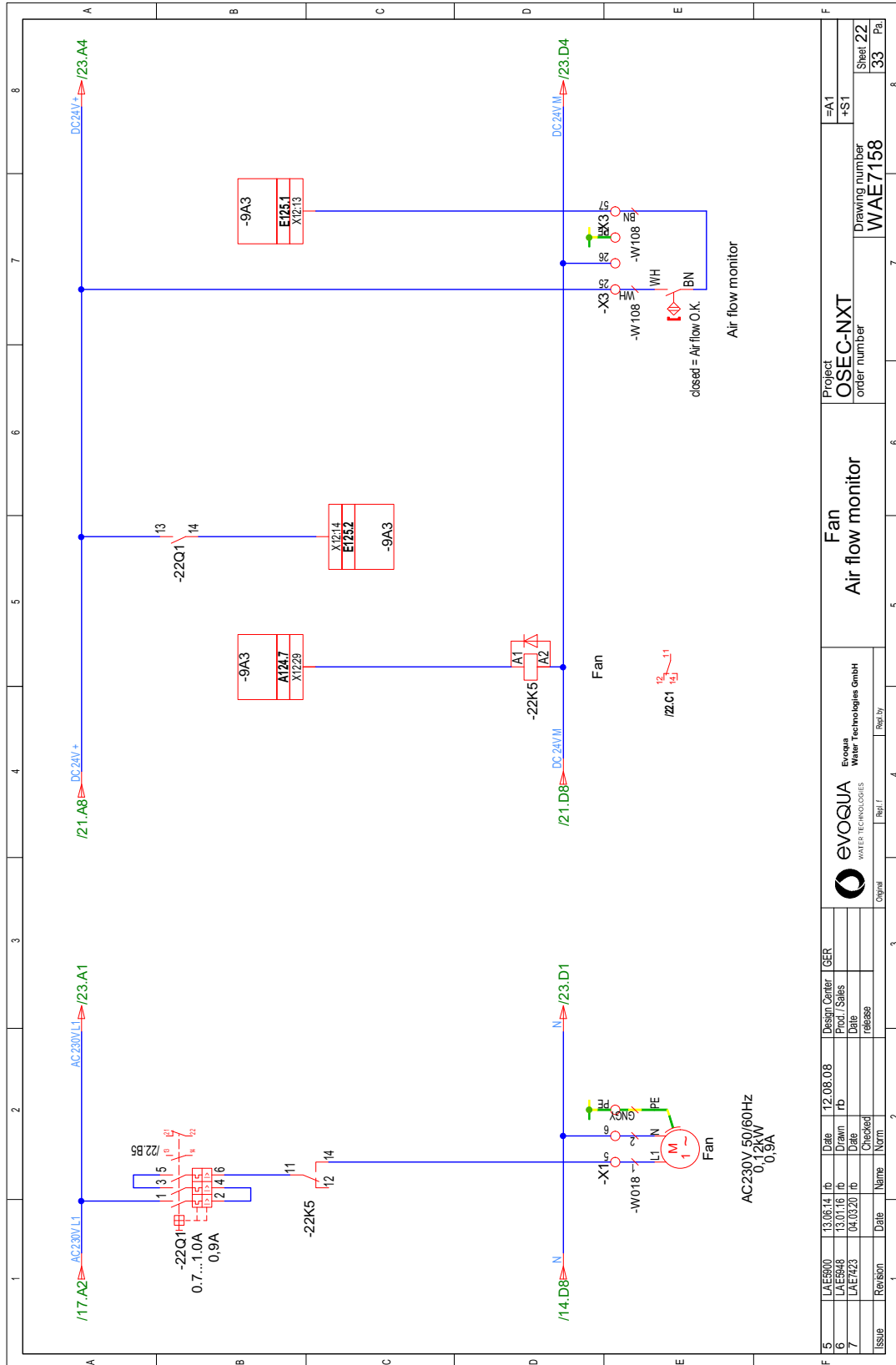

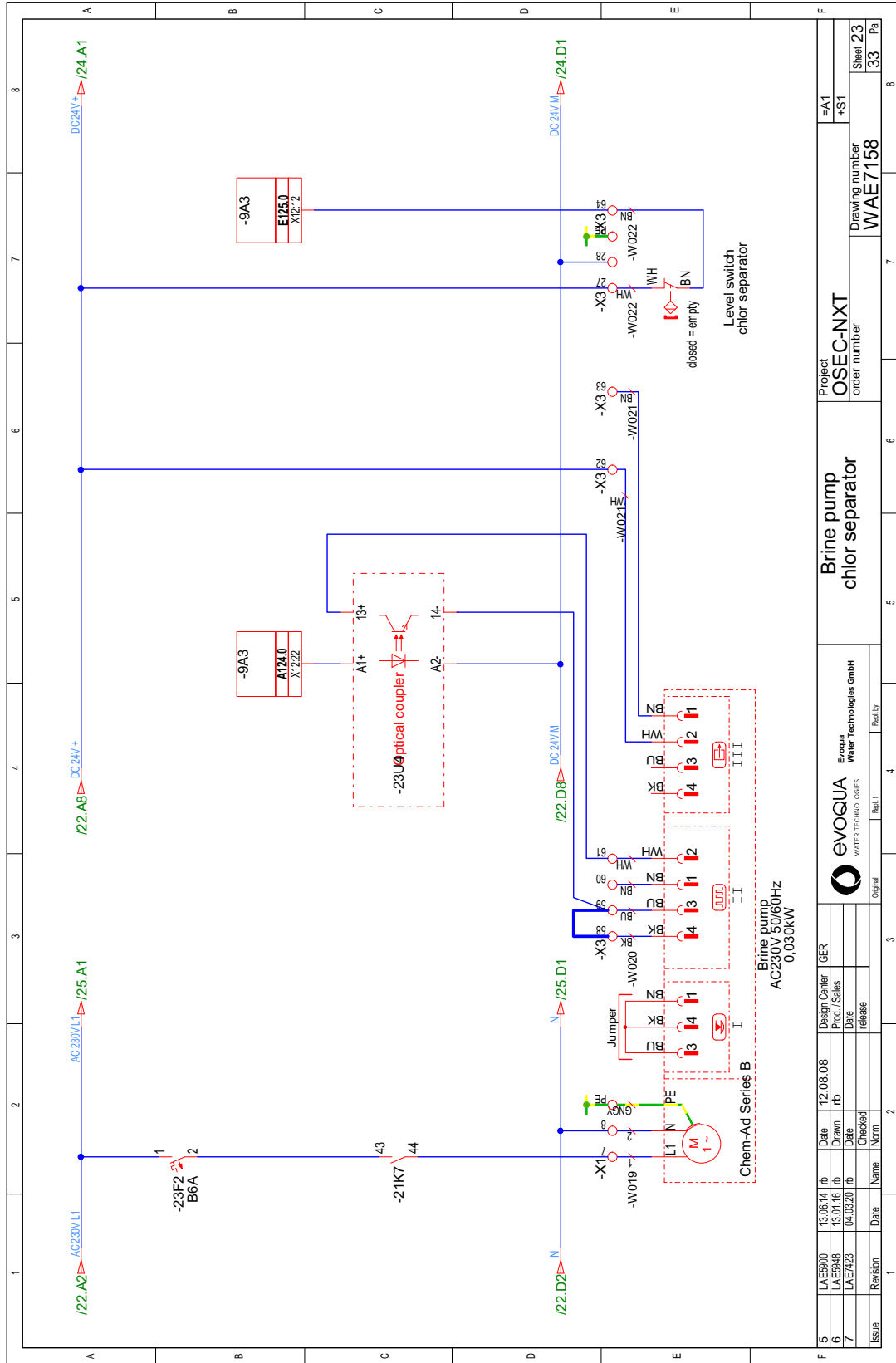

5	LAE800	13.06.14	fb	Date	12.08.08	GER	Design Center	Project	OSEC-NXT	Order number	WAE7158	Sheet 22
6	LAE848	13.01.16	fb	Drawn	rd			Fan				33
7	LAE7423	04.03.20	fb	Date	release			Air flow monitor				33
Issue	Revision	Date	Name	Norm								Pa

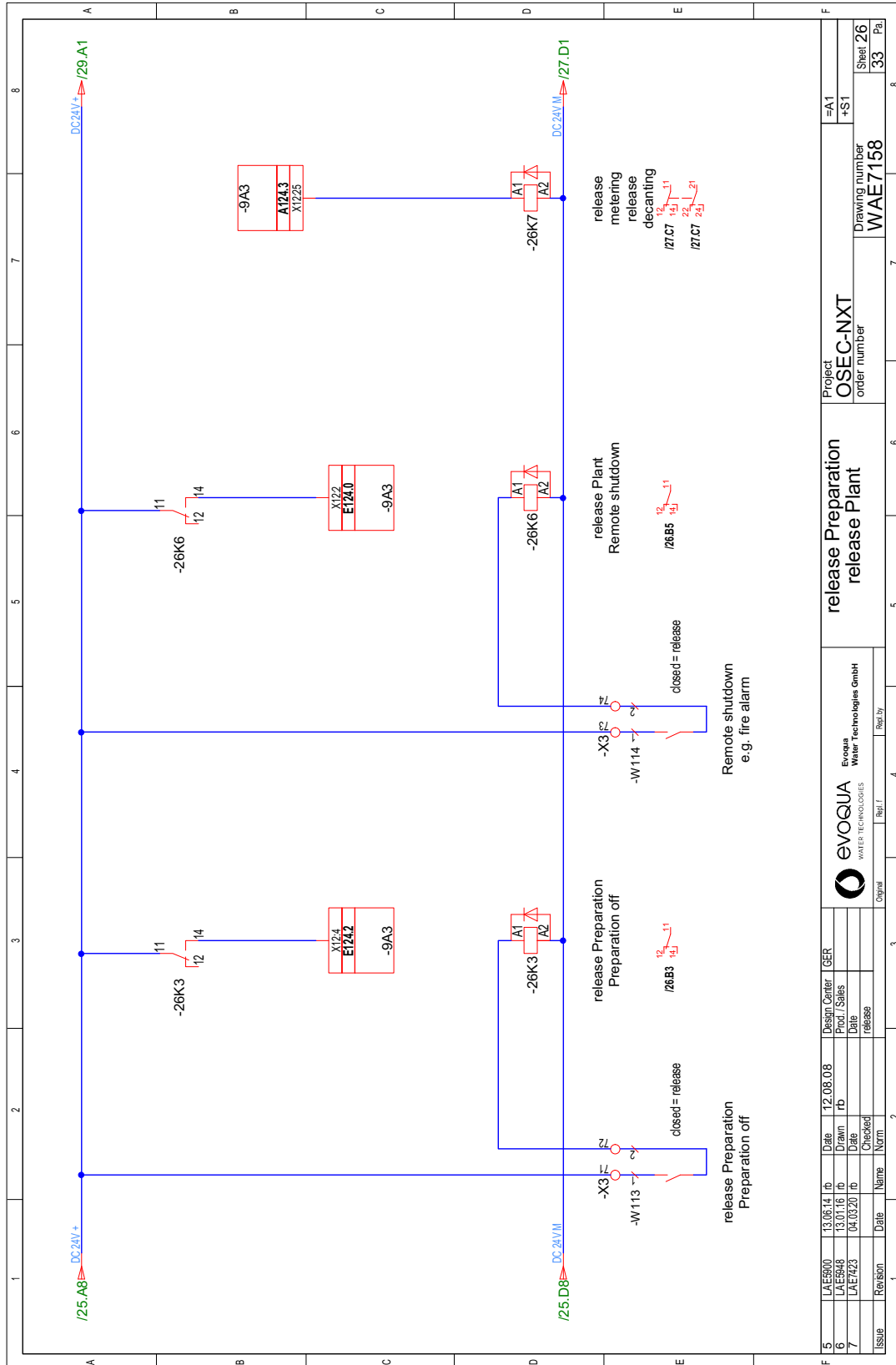



This page is left
free intentionally

1	2	3	4	5	6	7	8
A	B	C	D	E	F		
5	6	7			Project	=A1	8
LAE800	13.06.14	12.08.08	GER	free sheet		+S1	9
LAE848	13.01.16	rd	Design Center	OSEC-NXT		Drawing number	Sheet 28
LAE7423	04.03.20	rd	Prod./Sales	order number		WAE7158	33
Revision	Date	Name	release			Pa.	6
Issue	Date	Name	release			Pa.	6
			Original	Repl. I	Repl. II	Repl. III	Repl. IV
			 evoQUA WATER TECHNOLOGIES		Evoqua Water Technologies GmbH		

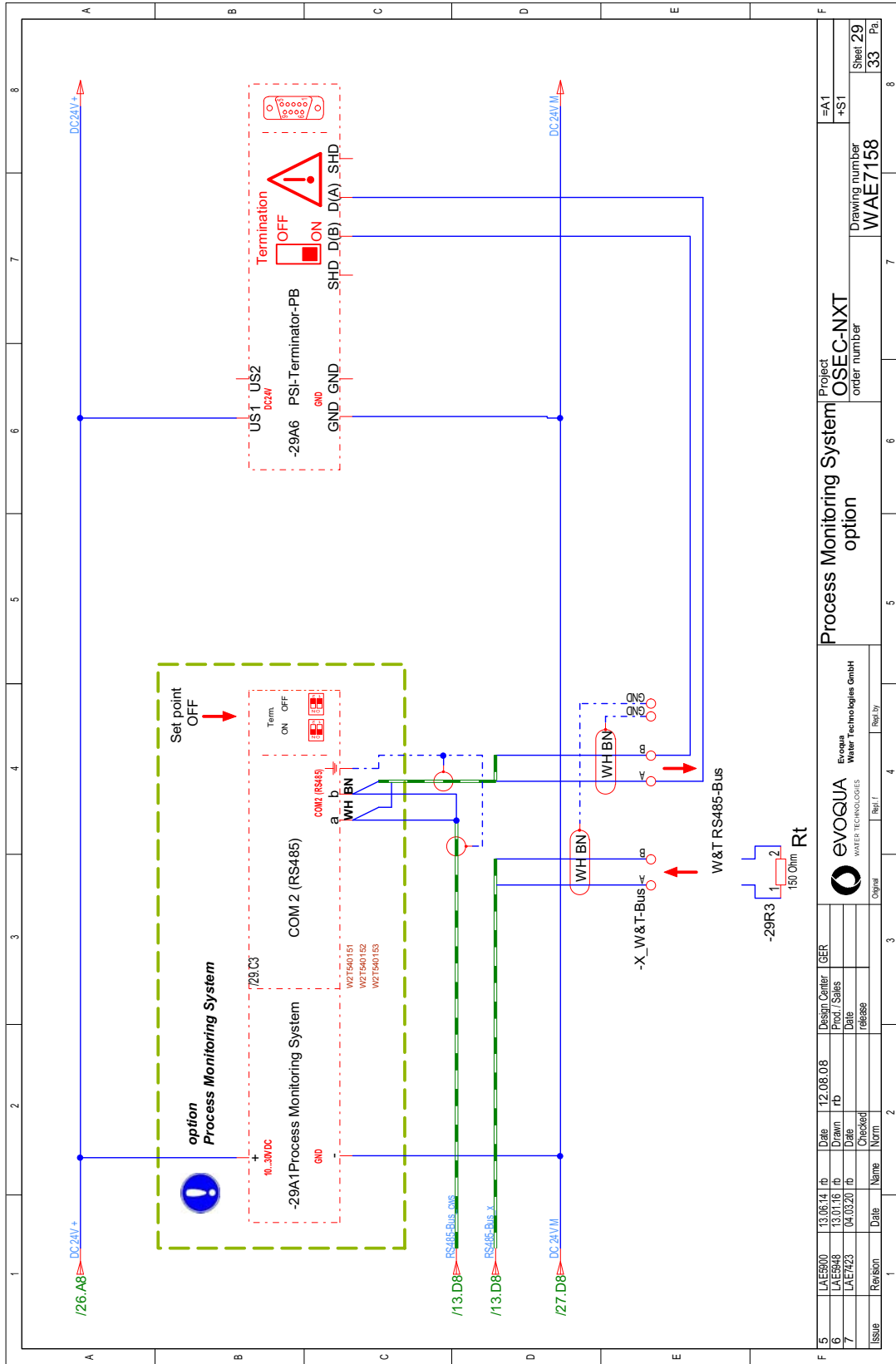

Issue	Revision	Date	Name	Norm	Checked	Date	Design Center	GER
5	LAE6900	13.06.14	rb			12.08.08		
6	LAE6448	13.01.16	rb					
7	LAE7423	04.03.20	rb					

Original	Repl. T	Repl. J	Repl. by

Project		=A1	
Process Monitoring System		+ST	
order number		WAE7158	
Drawing number		WAE7158	
Sheet 29		33	
Pa.		6	

1	2	3	4	5	6	7	8																																																																																																											
A	B	C	D	E	F																																																																																																													
<div style="display: flex; justify-content: space-between;"> <div style="width: 20%;"> <p>name plate</p> <table border="1" style="width: 100%; border-collapse: collapse;"> <tr> <td style="width: 50%;"></td> <td style="width: 50%;"></td> </tr> <tr> <td colspan="2" style="font-size: small;">Evoqua Water Technologies GmbH Alders Weg 10 89312 Günzburg</td> </tr> <tr> <td>order number : WAE7157.DE / WAE7158.EN / WAE7159.FR</td> <td></td> </tr> <tr> <td>wiring diagram no. : EAE1082</td> <td></td> </tr> <tr> <td>software : 1/N/PE AC 230V 50/60Hz</td> <td></td> </tr> <tr> <td>Main power supply : 2,4 kVA</td> <td></td> </tr> <tr> <td>power consumption : 1x20 A</td> <td></td> </tr> <tr> <td>Prefuse max : DC 24V, 120VA</td> <td></td> </tr> <tr> <td>control voltage : IP13</td> <td></td> </tr> <tr> <td>Protection : IP13</td> <td></td> </tr> <tr> <td>manufactured/tested as per : DIN EN 60204-1 / DIN EN 61439-1</td> <td></td> </tr> <tr> <td>id no./series no. :</td> <td></td> </tr> </table> </div> <div style="width: 20%;"> <p>control cabinet</p> <p>dimensions : 600 x 1200 x 300mm color : RAL7035 Protection : IP13 cable inlet : below door hinge : DIN left</p> </div> <div style="width: 20%;"> <p>wiring</p> <table border="1" style="width: 100%; border-collapse: collapse;"> <thead> <tr> <th>terminal</th> <th>description</th> <th>potential</th> <th>color</th> <th>cross section</th> </tr> </thead> <tbody> <tr> <td>X1</td> <td>Main power supply</td> <td>AC400/230V 50/60Hz</td> <td>BK/BU</td> <td>4mm²</td> </tr> <tr> <td>X2</td> <td>power</td> <td>AC400/230V 50/60Hz</td> <td>BK/BU</td> <td>2,5, 6mm²</td> </tr> <tr> <td>X3</td> <td>control</td> <td>AC230V 50/60Hz</td> <td>RD</td> <td>1mm²</td> </tr> <tr> <td>X4</td> <td>signal</td> <td>DC24V</td> <td>BU</td> <td>1mm²</td> </tr> <tr> <td>X5</td> <td>dry contact</td> <td>0/2..10V - 0/4..20mA</td> <td>L1YCY</td> <td>0,25mm²</td> </tr> <tr> <td>X10</td> <td>potential</td> <td>?</td> <td>OG</td> <td>1mm²</td> </tr> <tr> <td>X20</td> <td>potential</td> <td>AC400/230V 50/60Hz</td> <td>BK/BU</td> <td>2,5mm²</td> </tr> <tr> <td>X30</td> <td>potential</td> <td>AC230V 50/60Hz</td> <td>RD</td> <td>1mm²</td> </tr> <tr> <td>X40</td> <td>potential</td> <td>DC24V</td> <td>BU</td> <td>1mm²</td> </tr> <tr> <td></td> <td></td> <td>0/2..10V - 0/4..20mA</td> <td>L1YCY</td> <td>0,25mm²</td> </tr> </tbody> </table> </div> <div style="width: 20%;"> <p>color</p> <table border="1" style="width: 100%; border-collapse: collapse;"> <tr><td>BK</td><td>black</td></tr> <tr><td>BN</td><td>brown</td></tr> <tr><td>RD</td><td>red</td></tr> <tr><td>OG</td><td>orange</td></tr> <tr><td>YE</td><td>yellow</td></tr> <tr><td>GN</td><td>green</td></tr> <tr><td>BU</td><td>blue</td></tr> <tr><td>VT</td><td>violet</td></tr> <tr><td>GY</td><td>grey</td></tr> <tr><td>WH</td><td>white</td></tr> <tr><td>PK</td><td>pink</td></tr> <tr><td>GD</td><td>gold</td></tr> <tr><td>TQ</td><td>turquoise</td></tr> <tr><td>SR</td><td>silver</td></tr> </table> </div> </div>										Evoqua Water Technologies GmbH Alders Weg 10 89312 Günzburg		order number : WAE7157.DE / WAE7158.EN / WAE7159.FR		wiring diagram no. : EAE1082		software : 1/N/PE AC 230V 50/60Hz		Main power supply : 2,4 kVA		power consumption : 1x20 A		Prefuse max : DC 24V, 120VA		control voltage : IP13		Protection : IP13		manufactured/tested as per : DIN EN 60204-1 / DIN EN 61439-1		id no./series no. :		terminal	description	potential	color	cross section	X1	Main power supply	AC400/230V 50/60Hz	BK/BU	4mm ²	X2	power	AC400/230V 50/60Hz	BK/BU	2,5, 6mm ²	X3	control	AC230V 50/60Hz	RD	1mm ²	X4	signal	DC24V	BU	1mm ²	X5	dry contact	0/2..10V - 0/4..20mA	L1YCY	0,25mm ²	X10	potential	?	OG	1mm ²	X20	potential	AC400/230V 50/60Hz	BK/BU	2,5mm ²	X30	potential	AC230V 50/60Hz	RD	1mm ²	X40	potential	DC24V	BU	1mm ²			0/2..10V - 0/4..20mA	L1YCY	0,25mm ²	BK	black	BN	brown	RD	red	OG	orange	YE	yellow	GN	green	BU	blue	VT	violet	GY	grey	WH	white	PK	pink	GD	gold	TQ	turquoise	SR	silver
Evoqua Water Technologies GmbH Alders Weg 10 89312 Günzburg																																																																																																																		
order number : WAE7157.DE / WAE7158.EN / WAE7159.FR																																																																																																																		
wiring diagram no. : EAE1082																																																																																																																		
software : 1/N/PE AC 230V 50/60Hz																																																																																																																		
Main power supply : 2,4 kVA																																																																																																																		
power consumption : 1x20 A																																																																																																																		
Prefuse max : DC 24V, 120VA																																																																																																																		
control voltage : IP13																																																																																																																		
Protection : IP13																																																																																																																		
manufactured/tested as per : DIN EN 60204-1 / DIN EN 61439-1																																																																																																																		
id no./series no. :																																																																																																																		
terminal	description	potential	color	cross section																																																																																																														
X1	Main power supply	AC400/230V 50/60Hz	BK/BU	4mm ²																																																																																																														
X2	power	AC400/230V 50/60Hz	BK/BU	2,5, 6mm ²																																																																																																														
X3	control	AC230V 50/60Hz	RD	1mm ²																																																																																																														
X4	signal	DC24V	BU	1mm ²																																																																																																														
X5	dry contact	0/2..10V - 0/4..20mA	L1YCY	0,25mm ²																																																																																																														
X10	potential	?	OG	1mm ²																																																																																																														
X20	potential	AC400/230V 50/60Hz	BK/BU	2,5mm ²																																																																																																														
X30	potential	AC230V 50/60Hz	RD	1mm ²																																																																																																														
X40	potential	DC24V	BU	1mm ²																																																																																																														
		0/2..10V - 0/4..20mA	L1YCY	0,25mm ²																																																																																																														
BK	black																																																																																																																	
BN	brown																																																																																																																	
RD	red																																																																																																																	
OG	orange																																																																																																																	
YE	yellow																																																																																																																	
GN	green																																																																																																																	
BU	blue																																																																																																																	
VT	violet																																																																																																																	
GY	grey																																																																																																																	
WH	white																																																																																																																	
PK	pink																																																																																																																	
GD	gold																																																																																																																	
TQ	turquoise																																																																																																																	
SR	silver																																																																																																																	
<table border="1" style="width: 100%; border-collapse: collapse;"> <tr> <td style="width: 20%;"></td> <td style="width: 20%;"></td> <td style="width: 20%;"></td> <td style="width: 20%;"></td> <td style="width: 20%;"></td> <td style="width: 20%;"></td> <td style="width: 20%;"></td> <td style="width: 20%;"></td> </tr> <tr> <td>5</td> <td>LAE800</td> <td>13.06.14</td> <td>ib</td> <td>Date</td> <td>12.08.08</td> <td>GER</td> <td>Design Center</td> </tr> <tr> <td>6</td> <td>LAE848</td> <td>13.01.16</td> <td>ib</td> <td>Drawn</td> <td>rd</td> <td></td> <td>Prod./Sales</td> </tr> <tr> <td>7</td> <td>LAE7423</td> <td>04.03.20</td> <td>ib</td> <td>Date</td> <td></td> <td></td> <td>release</td> </tr> <tr> <td>Issue</td> <td>Revision</td> <td>Date</td> <td>Name</td> <td>Norm</td> <td>Checked</td> <td>Original</td> <td>Read by</td> </tr> <tr> <td></td> <td></td> <td></td> <td></td> <td></td> <td></td> <td></td> <td></td> </tr> </table>																5	LAE800	13.06.14	ib	Date	12.08.08	GER	Design Center	6	LAE848	13.01.16	ib	Drawn	rd		Prod./Sales	7	LAE7423	04.03.20	ib	Date			release	Issue	Revision	Date	Name	Norm	Checked	Original	Read by																																																																			
5	LAE800	13.06.14	ib	Date	12.08.08	GER	Design Center																																																																																																											
6	LAE848	13.01.16	ib	Drawn	rd		Prod./Sales																																																																																																											
7	LAE7423	04.03.20	ib	Date			release																																																																																																											
Issue	Revision	Date	Name	Norm	Checked	Original	Read by																																																																																																											
<table border="1" style="width: 100%; border-collapse: collapse;"> <tr> <td style="width: 20%;"></td> <td style="width: 20%;"></td> <td style="width: 20%;"></td> <td style="width: 20%;"></td> <td style="width: 20%;"></td> <td style="width: 20%;"></td> <td style="width: 20%;"></td> <td style="width: 20%;"></td> </tr> <tr> <td colspan="4"></td> <td colspan="2" style="text-align: center;"> </td> <td colspan="2"></td> </tr> <tr> <td colspan="4"></td> <td colspan="2" style="text-align: center;"> Evoqua Water Technologies GmbH </td> <td colspan="2"></td> </tr> <tr> <td colspan="4"></td> <td colspan="2" style="text-align: center;"> name plate wiring Accessories </td> <td colspan="2"></td> </tr> <tr> <td colspan="4"></td> <td colspan="2" style="text-align: center;"> Project OSEC-NXT order number </td> <td colspan="2"></td> </tr> <tr> <td colspan="4"></td> <td colspan="2" style="text-align: center;"> Drawing number WAE7158 </td> <td colspan="2"></td> </tr> <tr> <td colspan="4"></td> <td colspan="2" style="text-align: center;"> Sheet 30 33 </td> <td colspan="2"></td> </tr> <tr> <td colspan="4"></td> <td colspan="2" style="text-align: center;"> Pa. </td> <td colspan="2"></td> </tr> </table>																												Evoqua Water Technologies GmbH								name plate wiring Accessories								Project OSEC-NXT order number								Drawing number WAE7158								Sheet 30 33								Pa.																																														
				Evoqua Water Technologies GmbH																																																																																																														
				name plate wiring Accessories																																																																																																														
				Project OSEC-NXT order number																																																																																																														
				Drawing number WAE7158																																																																																																														
				Sheet 30 33																																																																																																														
				Pa.																																																																																																														
A	B	C	D	E	F																																																																																																													

bill of materials: W3T166861									
No.	Qty.	Equipment identifier	Part-no.	Description	Manufacturer	Order no.			
1	1	-29A6	W2T547861	Terminator active, RS485/PROFIBUS					
2	1	-21K7	W2T826187	Suppression diode S00					
3	1	-17G1	W3T349736	DC-power-supply DC10V 150A					
4	1	-11Q1	W2T504309	emergency stop switch 25A 3-p					
5	1	-21K7	W2T826713	auxiliary contactor DC24V, 40					
6	1	-21K7	W2T826716	auxiliary switch block 40					
7	5	-306.22	W2T503862	H07V-K 1x70mm² control cable					
8	2	-306.20	W2T504634	LIYCY 2x0,25mm² Control cable					
9	2	-306.21	W2T505957	LIYCY 8x0,25mm² Control cable					
10	1	-30A6	W3T360268	terminal OSEC-NXT 1 Zeile/Cell.					
11	7	-16K2 -20K6 -20K8 -21K3 -21K6 -25K4 -26K7	W2T504096	Switching relays DC24V, 2NONC					
12	5	-16K6 -17K3 -22K5 -26K3 -26K6	W2T504273	Switching relays DC24V, 1NONC					
13	1	-14K7	W2T504804	Switching relays AC230V, 2NONC					
14	1	-16K2	W2T505796	relay bridge 2NO/NC					
15	5	-16K6 -17K3 -22K5 -26K3 -26K6	W2T505627	Relays terminal					
16	1	-16K6	W2T506866	relay bridge 1NO/NC					
17	1	-22Q1	W2T825469	Auxiliary contact					
18	1	-22Q1	W2T825482	circuit breaker 0,7 ..1,0A					
19	3	-14F2 -23F2 -25F2	W2T504074	circuit breaker B6A, 1-p					
20	1	-17F1	W2T504077	circuit breaker B16A, 1-p					
21	1	-12F2	W2T504084	circuit breaker C10A, 1-p					
22	1	-14F2	W2T506237	auxiliary contact 1NO/1NC					
23	1	-12R7	W3T168604	Resistor Pt 100					
24	1	-15U7	W2T827016	isolator 24VUC					
25	1	-23U4	W2T505772	Optical coupler DC24V, 1 channel					

bill of materials									
Issue		Revision		Date		Name		Norm	
5	LAE800	13.06.14	fb	Date	12.08.08	Desim	Center	GER	
6	LAE848	13.01.16	fb	Drawn	rd	Prod./Sales			
7	LAE743	04.03.20	fb	Date		release			

Original	Repl. I	Repl. II	Repl. III
----------	---------	----------	-----------

Project order number	OSEC-NXT
Drawing number	WAE7158
Sheet	31
Page	33

bill of materials: W3T166861									
No.	Qty.	Equipment identifier	Part-no.	Description	Manufacturer	Order no.			
26	1	-A1	W3T368617	control cabinet 600x1200x300mm					
27	1	-0	W2T505826	label "attention"					
28	1	-116	W2T507237	label "attention"					
29	2	-307.5-308.3	W2T506084	Plain washer 8mm					
30	2	-308-307.2	W3T161582	Screw M8x20mm					
31	2	-307-307.1	W3T172418	Cable socket 70mm²/M8					
32	2	-307.4-308.2	W3T172730	Plain washer 8,4x17mm					
33	2	-307.3-308.1	W3T172818	hexagon nuts M8					
34	1	-13A7	W2T816358	Operator Panel KTP700 Basic color DP 2nd Gen.					
35	1	-9A3	W2T504304	Memory module 128kB					
36	1	-9A3	W2T504466	S7-300 CPU314C-2 DP					
37	1	-9A6	W2T504626	S7-300 SM323 8DI/8DO, DC24V					
38	1	-9A3	W2T504921	Plug 40 pin					
39	1	-9A6	W2T504927	Plug 20 pin					
40	1	-9A3	W2T504928	Plug 40 pin					
41	1	-9A5	W2T505096	Communications processor CP341					
42	1	-9A3	W2T506123	Sectional bar					
43	1	-9G1	W2T506697	Power supply					
44	1	-9A3	W3T162698	Connecting cable S7 AG - HMI 1,6m					
45	1	-9A5	W3T172486	Connecting cable S7-CP341-RS485-Bus					
46	1	-30WG.1	W3T164923	wiring set OSEC-NT 150-300					
47	1	-30WG	W3T172460	wiring bridge OSEC-NT 150-300					
48	1	-306	W2T504177	cable gland M12					
49	1	-306.1	W2T504178	cable gland M16					
50	1	-306.2	W2T504179	cable gland M20					
51	2	-306.3-306.4	W2T504180	cable gland M25					

bill of materials									
Issue	Revision	Date	Name	Norm	Checked	Date	Drawn	Date	Design Center
5	LAE800	13.06.14	rb			12.08.08	GER		
6	LAE848	13.01.16	rb						
7	LAE743	04.03.20	rb						

Original	Repl. I	Repl. II	Repl. III
----------	---------	----------	-----------

Project order number	OSEC-NXT
Drawing number	WAE7158
Sheet	32
Page	33

11.Certificate of Conformity



EG-Konformitätserklärung EC Declaration of Conformity Déclaration CE de conformité

No. MAE 1597

Ausgabe/issue/édition 02

Hersteller/Manufacturer/Constructeur:	Evoqua Water Technologies GmbH
Anschrift/Address/Adresse:	Auf der Weide 10, D-89312 Günzburg
Produktbezeichnung: Product description: Description du produit:	Chlor-Membranelektrolyse-Anlage OSEC-NXT 6 Chlorine Membrane Electrolysis System OSEC-NXT 6 Electrolyseur de chlore à membrane OSEC-NXT 6

Das bezeichnete Produkt stimmt in der von uns in Verkehr gebrachten Ausführung mit den Vorschriften folgender europäischer Richtlinien überein:

The product described above in the form as delivered is in conformity with the provisions of the following European Directives:

Le produit désigné est conforme, dans la version que nous avons mise en circulation, avec les prescriptions des directives européennes suivantes :

- | | |
|------------|--|
| 2006/42/EG | Richtlinie des Europäischen Parlaments und des Rates vom 17. Mai 2006 über Maschinen und zur Änderung der Richtlinie 95/16/EG (Neufassung).
<i>Directive of the European Parliament and of the Council of 17 May 2006 on machinery, and amending Directive 95/16/ED (recast).</i>
Directive du Parlement européen et du Conseil du 17 mai 2006 relative aux machines et modifiant la directive 95/16/CE (refonte). |
| 2014/30/EU | Richtlinie des Europäischen Parlaments und des Rates vom 26. Februar 2014 zur Harmonisierung der Rechtsvorschriften der Mitgliedstaaten über die elektromagnetische Verträglichkeit.
<i>Directive of the European Parliament and of the Council of 26 February 2014 on the approximation of the laws of the Member States relating to electromagnetic compatibility.</i>
Directive du Parlement européen et du Conseil du 26 février 2014 relative au rapprochement des législations des Etats membres concernant la compatibilité électromagnétique. |
| 2014/35/EU | Richtlinie des Europäischen Parlaments und des Rates vom 26. Februar 2014 zur Harmonisierung der Rechtsvorschriften der Mitgliedstaaten betreffend elektrische Betriebsmittel zur Verwendung innerhalb bestimmter Spannungsgrenzen.
<i>Directive of the European Parliament and of the Council of 26 February 2014 on the harmonisation of the laws of Member States relating to electrical equipment designed for use within certain voltage limits.</i>
Directive du Parlement européen et du Conseil du 26 février 2014 concernant le rapprochement des législations des Etats membres relatives au matériel électrique destiné à être employé dans certaines limites de tension.
CE-Kennzeichnung / CE marking / Marquage CE: 2016 |

Ersteller : SR
Ausgabe : 10.03.2016
Dokument: VD130-1_CE_Konformitätserklärung.doc

Evoqua Water Technologies GmbH
Auf der Weide 10
89312 Günzburg
Deutschland

Tel.: +49 (8221) 904-0
Fax: +49 (8221) 904-203
www.evoqua.com

Seite 1 von 2



Die Konformität mit den Richtlinien wird nachgewiesen durch die Einhaltung der in der Nachweisdokumentation aufgelisteten Normen.

Evidence of conformity to the Directives is assured through the application of the standards listed in the relevant documentation.

La conformité avec les directives est assurée par le respect des normes listés dans la documentation technique correspondante.

Benannte Person für technische Unterlagen:

Authorized person for the technical file:

Personne désignée pour la documentation technique:

Name / name / nom: Evoqua Water Technologies GmbH

Adresse / address / adresse: Auf der Weide 10, D-89312 Günzburg

Günzburg, den / the 20.09.2016

Evoqua Water Technologies GmbH

Klaus Andre
Leiter Entwicklung / Director Engineering

Unterschrift
signature / signature

Helmut Fischer
Leiter QM / Quality Manager

Unterschrift
signature / signature

Diese Erklärung bescheinigt die Übereinstimmung mit den genannten Richtlinien, ist jedoch keine Beschaffenheits- oder Haltbarkeitsgarantie nach §443 BGB. Die Sicherheitshinweise der mitgelieferten Produktdokumentation sind zu beachten.

This declaration certifies the conformity to the specified directives but does not imply any warranty for properties. The safety documentation accompanying the product shall be considered in detail.

La présente déclaration atteste de la concordance avec les directives citées, elle n'offre cependant pas de garantie quant à la nature ou la durabilité selon l'article 443 du code civil allemand. Les consignes de sécurité de la documentation du produit fournie sont à respecter.

12.Index

A

- Abbreviations 39, 47, 106, 149, 197
- Accessories 33
- Accident 18
- Activating
 - preparation manually 101
- Additional tools 165
- Adjust date/time 140
- Admission pressure
 - Operating water 37
- Air exchange 36
- Air flow monitor 33
 - Connect input 43
 - Fault 161
 - install 42
- Alarm horn 28
- Alarm light 28
- Alarm relay 44
- Alarm relay assignment 122
- Ambient conditions 11, 19, 36
- Analog inputs 133
- Analog outputs 133
- Anode 21, 25, 55
- Anode chamber 21
- Anolyte 15, 17, 21
- Anolyte circuit 176
- Answer frame 83
- Automatic mode 97, 156, 161
- Automatic stopcock 28, 49, 160
- Automatic stopcock will not open 160

B

- Brine 17, 21, 47, 55
- Brine flow
 - Fault 163
- Brine pump 19, 23, 24, 25, 27, 137
 - Errors 160
 - Fault 160
 - maintenance 182
 - Manual brine pump 143
- Brine tank filling connection 197
- Buttons 94

C

- calibrate
 - the electrolysis water 137
- Calibrate operator display 139
- Calibrating the display 139
- Cathode 21, 24
- Cell voltage 28
- Cell voltage too high 158
- Change display language 139
- Check byte 79
- Check operating water pressure 50
- Check the product concentration 173
- Checking and cleaning the filter 155
- Checking the product temperature 173
- Chemicals 14
- Chlorine gas 15, 17, 21, 25, 176
- Chlorine gas alarm 28, 162
- Chlorine separator 21, 24, 28
 - Fill level 56
- Chlorine separator level
 - Salt dissolving tank 48
- Clean display 138
- Clean the
 - injector 183
- Collecting basin 40
- Communication protocol 78
- Complete acceptance certificate 46
- Connect inputs 43
- Connect power supply 45
- Connecting outputs 44
- Connecting the interfaces 45
- Connections 39
 - Electrical 43
 - Electrolysis cell 24
 - Hose connections 197
 - Mechanical 41
- Control and display unit 93
- Control cabinet 13, 24, 26, 36
 - Electrical installation 43
 - Wiring diagram 199
- Control unit 24, 26
- Cooling water 27, 28

- Ball valve drain 197
- Drain 38, 41, 197
- MANUAL Cooling water 142
- Solenoid valve 197
- Cover 24
- Customer services 165

- D**
- Data check (DC) 80
- Data unit (DU) 80
- Description 21
- Description of the frame bytes 79
- Destination address (ZA) 79
- Detailed maintenance work 172
- Diagnostics 127
- Digital inputs 43, 131
- Digital outputs 44, 132
- Display 27, 93
- Display contrast 138
- Display unit 26
- Dosing ball valve
 - Operating water 50
- Dosing leak 161
- Dosing pump 22, 161
- Dosing pumps 22
- Drawings
 - Arrangement of components 195
 - Component Parts List 197
- Drinking water 21, 24, 37
- Drum pump 33, 48

- E**
- Electrical
 - Installation 43
- Electrical installation 43
- Electrical power rating
 - Nominal system performance 26
- Electrolysis 136
- Electrolysis cell 19, 21
 - Pro-Rata 20
- Electrolysis cells 23, 24
- Electrolysis current 27, 28
- Electrolysis current too low 158
- Electrolysis power 58, 107
- Electrolysis water 27, 28, 128, 142
 - check flow rate 114
- Errors 163
- Flow meter 163
- Set flow rate 50
- Solenoid valve 197
 - the electrolysis water 154
- Electrolysis water flow meter 197
- EMERGENCY STOP 28, 43, 162
- Empty
 - Anode chamber 176, 190
 - Cathode chamber 175
- Empty the anode chamber
 - 175, 176, 190
- Empty the cathode chamber 52
 - 175, 190
- End byte (EB) 80
- Error message 57
- Error message log 129
- Error messages 27, 118, 158, 161, 163
- Errors 156
- EU Safety Data Sheet 18
- External release 109
- External water softener 43, 159

- F**
- Fan 19, 22, 23
- Fan failure 162
- Fill level
 - Chlorine separator 106
 - Salt dissolving tank 51
 - Sodium hypochlorite storage tank 97
- Filling
 - Salt dissolving tank 51
- Filter 19, 148, 155
- Final tasks 58
- First aid 18
- Flow meter 197
 - the electrolysis water 154
- Frame check (FC) 80
- Functions 29

- H**
- Handling chemicals 14
- Heat emission 36
- Hinged feet 33, 35, 39
- Hose connections 39, 40, 197
- Hydrogen 15, 16, 21, 28
 - Vent pipe 41
- Hydrogen vent hose 19, 184
- Hydrogen vent pipe 36, 53, 147, 184
- Hydrogen vent pipe 37

I

Impeller flow meter 197
 Info 130
 Information signs 14, 33
 Installation 33

- Chlorine membrane electrolysis system 39
- Connecting to Profibus DP 60
- Mechanical 39
- Personnel 12, 19
- RS485 bus interface 75

 Installation of the connections 41
 Installation room 36
 Interface connection 76
 Interfaces 28

L

Leaks 15, 38, 149, 156
 Level probe

- Chlorine separator 23, 25
- Salt dissolving tank 174

 Level switch

- Sodium hypochlorite storage tank 54

 level switch

- Chlorine separator 143

 Level switch of the chlorine separator 19
 Liability for defects 19, 165
 Log in 95

M

Main menu

- Service 134
- System 138

 Main menus 121

- Diagnostics 127
- Manual functions 141
- Outputs 122

 Main screen 94
 Main switch 19, 26, 45, 49, 156
 Maintenance 11, 19, 39, 128, 135

Additional tools 38
 annual 112
 Checklist 166
 Customer services 165
 daily 147
 Level 1 147
 Level 2 147
 monthly 112, 148
 Operator 147
 Personnel 12
 Protective clothing 14
 Wear parts 19
 Maintenance contract 20
 Maintenance overview 147
 Maintenance part sets 165, 167

- 1 year 168, 170
- 2 years 169

 Maintenance work

- Replacing the rectifier 185
- Replacing wear parts 177

 MANUAL Cooling water 142
 MANUAL cooling water 110
 MANUAL Electrolysis water 142
 MANUAL electrolysis water 110
 Manual functions 110, 141
 Manual keys

- Brine pump 143
- Cooling water 142
- Electrolysis water 142

 MANUAL top-up brine 110
 Measure individual cell voltage 172
 Measure the

- the air flow rate 148

 Measure the air flow 58
 Measure the hardness of the operating water

- . 148

 Measure the hardness of the softened water 50, 51
 Measure the soft water hardness 148, 152
 Measure the water hardness 50, 51
 Measuring the cell current 172
 Mechanical installation 39
 Membrane 20, 175, 176
 Menu selection 121
 Menus 121

N

Negative confirmation 84
 Number byte (AB) 80

O

Opening 37
 Operating data 127
 Operating hours 127
 Operating journal 19, 163, 233
 Operating messages 27, 103
 Operating water 37, 147
 Connection 41
 Hose connection 197
 Pressure reducing valve 197
 Operating water hardness 51
 Operation 93
 Operator training 59
 Outlet hardness 148
 Outputs 44, 122
 Overfilled 28
 Overflow mechanism 40

P

Parameter reset 136
 Parameters 19
 Password
 password 95
 Password protection 95
 Password levels 29
 Password protection 95
 Perform annual maintenance 112
 Perform monthly maintenance 112
 Personnel 7, 12, 19, 147
 Plant leak 161
 Plausibility
 Flow meter 163
 plausibility
 level probes NaClO 159
 Water softener 163
 PLC controller 27
 Potentially isolated RS485 bus system 77
 Potentially non-isolated RS485 bus system 77
 Power failure 35
 Power off 116
 Power supply 35, 43, 44, 45, 190
 Preparation 106
 ext. locked! 109
 Preparation active 97, 106
 Preparation count 127
 Preparation off 104
 Preparation running 107
 Preparation run-out 107
 Preparation standby 105
 Preparation start up 106
 Pressure reducing valve

 Filter 155
 Operating water 50, 147
 Prevention of risks 18
 Process 21
 Description 21
 Diagram 23
 Process Monitoring System 28
 Profibus DP 28
 Configuring the Profibus DP master 62
 Connecting Profibus DP 45, 60
 Connecting to Profibus DP 60
 Data exchange table 66
 Data formats 72
 Setting the Profibus DP slave 74
 Technical data 32, 60
 Protective clothing 14, 15, 18
 Protective voltage 116, 120

R

Reactor 21, 23, 25
 Reading the
 cell voltage 120
 electrolysis current 120
 Rectifier 24, 28, 159
 Reduced brine 17, 21
 Release
 Dosing/decanting 44
 Preparation 43
 System EMERGENCY STOP 43, 162
 Remove the seal on the main switch 49
 Replace
 cells 187
 Components 13
 Electrolysis cell 20
 Replace the
 components 177
 electrolysis cells 187
 Replace the electrolysis cells
 187
 Replacing wear parts 177
 Replenish 148
 salt 150
 Replenishing the salt 150
 Replenishment
 Salt dissolving tank 27
 Request frame 81
 Rinse
 Anode chamber 176
 Cathode chamber 175
 Rinse the anode chamber
 190
 . 176
 Rinse the cathode chamber

- 175, 190
 - and rinse with acid 55
 - with acid 188
- RS485 Bus 45
- RS485 bus interface 28, 75
- Run time
 - Brine pump 160
- Run-up 58, 97, 106

- S**
- Safety 11
 - Chemicals 14
 - General safety instructions 12
 - Handling chemicals 12
 - Intended use 11
 - Personnel 12
 - Safety instructions 8, 12
- Salinometer 38, 48, 55, 165
- Salt 19, 25, 37, 48
- Salt dissolving tank 21, 23, 28, 134
 - Level probe 174
 - Max. filling time exceeded 159
 - Preparation 48
 - Replenishment 27
- Salt dissolving tank filling time 159
- Salt dissolving tank replenishment 28
- Salt pellets 19
- Sample tap 55, 148, 197
- Saturated brine 21, 25
- Scope of supply 33
- Separator 21
- Serial number 130
- Service 134, 165
 - Personnel 12
- Set the electrolysis water flow rate 50
- Set the language 49
- Setup 39
- Shut-down 35, 99, 163, 190
- Shutdown period 20, 35, 163, 190
- Signal contact 44
- Slave address (SA) 79
- Sodium hydroxide 15, 16, 21, 48
- Sodium hydroxide solution 16
- Sodium hypochlorite 15, 18, 22
 - manual request 101, 105
 - Preparation 97, 107
 - Waste disposal 40
- Sodium hypochlorite storage tank 22
- Sodium thiosulphate 176
- Softened water 21, 24, 148
- Software 130
 - version 130
- Solenoid valve 19
- Brine tank filling connection 197
- Cooling water 142, 197
- Electrolysis water 142, 197
- Softening flushing process 197
- Water softener injector 197
- Water softener water inlet 152, 197
- Spare parts 13, 187
- Special case 80
- Specification of the bus interface 78
- Spiral hose 41, 184
- Standby 103
 - Operating state 97
- Stands 33, 35, 39
- Start byte (SB) 79
- Start preparation 101
- Start up 47
 - Additional tools 38
 - Overview 48
 - Personnel 19
 - Prepare the salt dissolving tank 48
 - Tools 48
- Starting the system up again 192
- Start-up
 - Overview 166
 - Personnel 12
 - Procedure 48
 - Starting the system up again 192
- Stopping
 - preparation manually 102
- Storage tank 22
 - Level switch 54
- Storage tank empty 112
- Storage tank leak 161
- Storage tank overfilled 161
- Supply 34
- Synchronisation bytes 79
- System 138
- System configuration 24
- System Info 130

- T**
- Technical data 31
- Temperature drops 36
- Temporary parts 19, 20
- Test air flow monitor 53
- Test Flushing system 145
- Test Injector 146
- Test Inlet 145
- Test kit 33, 48, 50, 51, 152, 153
- Titration 38, 165, 173
- Touch Panel 27, 93
- Train and instruct operators 59
- Transmission medium 75

- Transport 34
- Transport and storage 34
- Transport plugs 40
- Transport rollers 39
- Turn on the chlorine membrane electrolysis system 49
- Turning off
 - automatic mode 99
- Turning on
 - automatic mode 99

- U
- Unpacking 34
- Using the
 - maintenance part sets 171

- W
- Warning message log 129
- Warning messages 27, 111
- Warranty 19, 165
- Waste disposal 13, 18
- Water hardness 148
 - Operating water 153
 - Soft water 152
- Water hardness of softened water 50, 148
- Water hardness test kit 33
- Water softener 21, 23, 24, 27, 28, 144
 - Check brine flow rate 115
 - Clean the injector 183
 - Electrical installation 43
 - Fault 159
 - regeneration 24, 28, 109
- Water softener regeneration 24, 28, 109
- Wear parts 19
- Wiring diagram 13, 199



Wallace & Tiernan[®] Products worldwide

Australia

+61 1300 661 809
info.au@evoqua.com

Canada

+1 905 944 2800
wtoc.can@evoqua.com

China

+86 21 5118 3777
sales.cn@evoqua.com

France

+33 1 41 15 92 20
wtfra@evoqua.com

Germany

+49 8221 9040
wtger@evoqua.com

Singapore

+65 6559 2600
sales.sg@evoqua.com

UK

+44 300 124 0500
info.uk@evoqua.com

USA

+1 800 524 6324
wt.us@evoqua.com



Wallace & Tiernan®
an EVOQUA brand



Auf der Weide 10, 89312 Günzburg, Germany

+49 (8221) 904-0 www.evoqua.com

DEPOLOX, OSEC, Barrier, Chem-Ad and Wallace & Tiernan are trademarks of Evoqua, its subsidiaries or affiliates, in some countries.

All rights, especially those to duplication and distribution as well as translation, are reserved. No part of this document may be reproduced in any form (printing, photocopying, microfilm or any other method) or saved, processed, duplicated or distributed by the use of electronic systems without the express written consent of Evoqua Water Technologies GmbH.

All information presented herein is believed reliable and in accordance with accepted engineering practices. Evoqua makes no warranties as to the completeness of this information. Users are responsible for evaluating individual product suitability for specific applications. Evoqua assumes no liability whatsoever for any special, indirect or consequential damages arising from the sale, resale or misuse of its products.

© 2020 Evoqua Water Technologies GmbH Subject to change without notice WT.085.130.000.DE.IM.0320
W3T163025 Issue 08-0320