



evoqua
WATER TECHNOLOGIES

Wallace & Tiernan® Instruction Manual V10k™ Gas Feeder

W3T292561 / WT.025.100.000.GE.IM.0914

Suite 3, 2nd Floor, One 60 London Road, Sevenoaks, TN13 1BT

Tel.: +44 1732 771777 Fax: +44 1732 771800 www.evoqua.com

Important Notice

Evoqua Water Technologies Instruction Manuals are the safety documents for their products. The information provided therein is in accordance with the best practices known at the time of issue and, if fully implemented, should enable the user to operate the plant in the safest possible manner. It is therefore most important that instructions be read and understood prior to the installation, operation or maintenance of the plant.

Notes

Where necessary, special instructions are provided and are quoted under the following headings:



WARNING: A warning is given in instances where failure to observe the instruction could result in injury to personnel.



CAUTION: Cautions are given where failure to observe the instruction may result in equipment damage, or pollution to an allied system.

NOTE: Notes are provided to give additional emphasis to particular points of detail.

The following recommendations are made to ensure safe and efficient operation:-

- 1 Only suitably qualified personnel should install, operate and maintain the equipment.
- 2 Only Evoqua Water Technologies manufactured or approved parts should be used.
- 3 The equipment should not be used for any purpose other than that for which it was supplied.
- 4 If equipment being supplied is being put into storage or not being commissioned immediately, or if the plant is being de-commissioned, Evoqua Water Technologies urge that they be contacted for detailed advice.

In an effort to make progressive improvements to products, changes in design may be incorporated from time to time, which may not be reflected immediately in the instruction manual. If in doubt, contact Evoqua Water Technologies quoting the equipment serial number; serial numbers are essential for effective communication and proper equipment identification.

The equipment described in this manual may be used with substances that themselves may be hazardous to personnel safety. It is essential that persons employed in the vicinity of such substances be aware of the appropriate safety practices and the location of suitable safety equipment. Provision of safety cards and codes of practice concerning hazardous substance should be made by the supplier of the substance.

Warranty

The equipment supplied is guaranteed against mechanical defect notified to the Seller within a period of 1 year from the date of delivery. For such guarantee to be valid the purchaser must notify the seller in writing immediately such defect becomes apparent. If the Seller so requires, the Purchaser shall return the defective equipment (at the Purchaser's expense) to the Seller. The Seller undertakes that it will, at its own option and its own expense, and by way of full discharge of its guarantee obligation hereunder, either repair, or supply a replacement for the defective equipment, or refund any purchase monies paid to it in respect of any such defective equipment, or portion thereof. If title to the defective equipment is at the time of such replacement or refund vested in the Purchaser, then title shall thereupon vest in the Seller. Replacement material situated outside the U.K. will be supplied F.O.B. U.K. Port. The guarantee given in this clause shall not be operative and enforceable if the equipment is not operated strictly in accordance with the seller's instruction, or in the respect of any defect arising from accident, deliberate act, misuse, neglect or from a breach from the terms of the following clause, or in respect of any defect arising through damage incurred while being transported after delivery of the equipment, or if the equipment has been altered or modified in any way by any person other than the seller, or in respect of any other cause whatsoever which lies beyond the Seller's control.

The Purchaser must comply with all user instructions and safety recommendations issued by the Seller, and must install, commission and maintain the equipment in accordance with good engineering practice, and under the supervision of suitably qualified personnel, and the Seller shall not be liable to the Purchaser for any loss suffered as a result of the Purchaser's breach of the terms of this clause.

Subject to this guarantee all conditions, warranties and representations, whether expressed or implied (by statute or otherwise) relating to the equipment, are hereby excluded in so far as they can be excluded without such exclusion being void or unenforceable at law.

Wallace & Tiernan, Barrier, Chem-Ad, DEPOLOX, OSEC, and V10k are trademarks of Evoqua, its subsidiaries or affiliates.

The designations used in this publication may be trademarks whose use by third parties for their own purposes could violate the rights of the owners. All rights, especially those to duplication and distribution as well as translation, are reserved. No part of this document may be reproduced in any form (printing, photocopying, microfilm or any other method) or saved, processed, duplicated or distributed by the use of electronic systems without the express written consent of Evoqua Water Technologies.



eVOQUA

WATER TECHNOLOGIES

International Contact Information

Area	Phone	email
Australia	+61 (0) 3 8720 6597	info.au@evoqua.com
Canada	+1 905 944 2800	canadainfo@evoqua.com
Germany	+49 8221 9040	wtger@evoqua.com
Singapore	+65 8630 7100	infosg@evoqua.com
U.S.A.	+1 856 507 9000	wtus@evoqua.com
U.K.	+44 (0) 1732 771777	info.uk@evoqua.com

INTRODUCTION

The Wallace & Tiernan Type V10k Gas Feeder described in this book, is designed for the precise metering of chlorine, sulphur dioxide, carbon dioxide or ammonia gas; to mix the gas with water and deliver the resultant solution to a point-of-application. The V10k is a manually operated unit with a automatic control option.

This manual has been produced to enable the user to obtain maximum service from the equipment and comprises installation, operating instructions, maintenance and spare parts information. Minor changes may be made to the equipment that are not immediately reflected in the manual - if such a change appears to have been made to your equipment, contact Evoqua Water Technologies for information.

Our guarantee is conditional upon the equipment being treated in accordance with the contents of this manual and its supplements. We invite particular attention to it and urge that its contents be thoroughly understood and rigidly followed.

Evoqua Water Technologies

CONTENTS

TITLE	SECTION
Warnings and notes on protective clothing	
Generic installation guidelines	
General description	1
Principle of operation	1.1
Gas feeder	1.2
Injectors	1.3
Vacuum demand valve	1.4
Vacuum switches	1.5
Technical data	1.6
Installation	2
Unpacking the equipment	2.1
Location requirements	2.2
Installing the gas feeder	2.3
Installing the injector	2.4
Point of application	2.5
Water supply and solution delivery pipelines	2.6
Installing the vacuum demand valve	2.7
Electrical connections	2.8

Operation	3
Preparation for initial operation	3.1
Operating procedures	3.2
Changing gas cylinders	3.3
Intermittent start/stop	3.4
Electronic controller	3.5
Maintenance	4
Cleaning the parts	4.1
Preventive maintenance kits	4.2
Maintenance of the Gas Feeder	4.3
Maintenance of the injector	4.4
Maintenance of the vacuum demand valve	4.5
Maintenance of aux. cylinder, drum and header valves	4.6
Adjusting the electric plug positioner	4.7
Fault finding	4.8

ILLUSTRATIONS

Typical V10k dosing system	Fig.1
V10k Gas Feeder	Fig.2
V10k flowmeters	Fig.2A
Vacuum differential valve	Fig.3
U.96273 injector	Fig.4
U.96274 injector	Fig.5
U.96275 injector	Fig.6
U.96276 injector	Fig.7
Single function vacuum switch	Fig.8
Double function vacuum switch	Fig.9
Universal yoke assembly	Fig.10
Chlorine Institute yoke assembly	Fig.11
Auxiliary cylinder valve	Fig.12
Auxiliary drum valve	Fig.13
Large header valve	Fig.14
Vacuum line connections	Fig.15
Header manifolds — multi-demand valve	Fig.16A
Header manifolds — multi-cylinder	Fig.16B
External connection diagram	Fig.17
Injector operating requirements	
Maintaining the suction demand valve	
Activated carbon filter UXA93889	

WARNINGS

1 HAZARDOUS CHEMICALS



All users of this gas feeder should be made aware of the problems associated with handling chlorine, sulphur dioxide and ammonia in either liquid or gaseous form and the effects of exposure to their fumes. Reference should be made to the literature available from the suppliers of these chemicals, paying particular attention to information and advice on protective clothing.

2 ELECTRICAL SAFETY



Mains voltage can kill. Before carrying out maintenance or repair, persons concerned must ensure that the equipment is isolated from the electrical supply and make tests to verify that isolation is complete.

If the supply cannot be isolated, functional testing, maintenance and repairs must be undertaken only by persons who are fully aware of the danger and who have taken adequate precautions.

3 GENERAL



To avoid possible severe personal injury or damage to plant this equipment should be installed, operated and serviced only by trained, qualified personnel who are thoroughly familiar with the entire contents of this instruction book.

The gas feeder and injector are designed to operate under vacuum only and, must under no circumstances be presented with gas above atmospheric pressure.





NOTES ON PROTECTIVE EQUIPMENT AND CLOTHING

The following warning is general in nature due to the variety of hazardous chemicals this equipment is capable of handling.



WARNING: When dealing with hazardous material it is the responsibility of the equipment user to obtain and follow all safety precautions recommended by the material manufacturer.

It is good general practice to make use of the following types of protective clothing when handling any hazardous liquid. IT IS RECOMMENDED THAT SUCH PROTECTIVE EQUIPMENT BE USED BY ALL PERSONS SERVICING THIS EQUIPMENT, ASSOCIATED PIPING, TUBING, VALVES, AND ACCESSORIES, WHEN THE EQUIPMENT IS HANDLING ANY HAZARDOUS LIQUID OR GAS.

- | | | |
|---|---|---|
| 1 | Goggles, flexible fitting, hooded ventilation (per BS EN 2092) |  |
| 2 | Face shield (BS EN 2092) |  |
| 3 | Chemical apron (BS EN 7184) |  |
| 4 | Chemical gloves (BS EN 7184) |  |
| 5 | Self contained, positive pressure breathing apparatus (BS 4667) |  |

NOTE : 1 BS EN 7028 “practice for occupational.....eye and face protection” recommends goggles (see 1 above) as the “preferred protection” when handling chemicals which present a hazard from splash, acid burns or fumes; for severe exposure, a face shield (see 2 above) over the goggles is recommended.

NOTE : 2 An eye flushing fountain and a deluge type shower may also be recommended.

GENERIC INSTALLATION GUIDELINES**FOR MAINTAINING EMC INTEGRITY****OF EQUIPMENT SUPPLIED BY EVOQUA WATER TECHNOLOGIES**

The Guidelines below are general in nature. They do not guarantee compliance with legislation. The Installers/Assemblers/End Users of equipment supplied by Evoqua Water Technologies should satisfy themselves as to the procedures required to ensure compliance. We recommend that Installers/Assemblers/End Users are familiar with the EMCD (Electromagnetic Compatibility Directive 89/336/EEC), the LVD (Low Voltage Directive 73/23/EEC) and the MSD (Machinery Safety Directive 86/392/EEC). The Guidelines below should not be taken as definitive and independent advice should be sought if in doubt.

The EMC Directive is applicable to “systems” it should be noted that some systems could be configured from apparatus supplied from different manufacturers. The onus is on the assembler of the system to meet the requirements of the directives.

The equipment you have been supplied with by Evoqua Water Technologies has been tested for compliance with the EMC Directive (Electromagnetic Compatibility Directive 89/336/EEC) and appropriately marked. It is important that the equipment is installed in a manner that will maintain the integrity of that EMC requirement, thus ensuring that complete system being installed/commissioned will comply. For this Purposes a “system” may be defined as a combination of electrical apparatus. The term apparatus can be defined as *Consisting of a product with an intrinsic function intended for the end user and is supplied or intended for supply or taken into service or intended to be taken into service as a single unit.*

Generic Guidelines

Having unpacked the equipment check all parts for obvious damage, If damage is apparent contact Evoqua Water Technologies immediately. If the system is not to be installed or commissioned immediately check the instruction manual for any special storage instructions.

The intended mounting of all equipment should be carefully planned in advance. The cable lengths should be accurately calculated so as to avoid unnecessary cable jointing.

Some of the equipment may have been supplied with special signal cables. Under no circumstances should any of these special cables be shortened or the connectors modified, changed or removed. If the cables supplied are too long then reference should be made to the relevant instruction manual or typical installation drawings (If supplied) to check

any recommendations made as to methods of excess cable storage. If the cables are too short contact Wallace & Tiernan for supply of correct cables (This would normally be advised at order time).

Any screened sensor cables should be run separately from all other cables and the screen should be earthed at the Control/Analyser equipment. Often this will be shown on the drawings.

All other cables should be run in ridged or flexible metal conduit or steel wire armoured cable securely bonded to earth.

Low Voltage signal cables such as those to relays should be routed separately to power cables.

All cable entries to metallic coated plastic or metal enclosures should be via metal glands secured inside the enclosure with unpainted metal retaining nuts and washers. In the case where plastic glands are supplied the signal cables should be passed through the gland and the screen should be connected and securely bonded as indicated on the drawing.

So as not to introduce conducted interference into some analysers and controllers consideration should be given to the possible filtering of the relay signal cables. This is very much dependant on usage. The type of switching that the relay is being asked to perform should be considered. In general if the relay signal is being fed to, and being processed by, another piece of Wallace & Tiernan equipment then external filtering will not be required.

In some instances you may find it necessary to supply connections into the Wallace & Tiernan equipment where glands are not provided. If this is required by your system configuration or the equipment supplied then care should be taken not to damage any RFI coating/screening applied to the inside of the enclosure. In order to minimise damage we would recommend that holes are drilled and not punched. This would also apply to existing gland “Knockouts”.

You are now advised to read the instruction manuals of the equipment supplied to find any additional information that may be relevant to the installation.

1 GENERAL DESCRIPTION

The Type V10k Gas Feeder is a V-notch type, vacuum operated, gas control unit designed to feed chlorine, sulphur dioxide, carbon dioxide or ammonia gas into a flow of water at dose rates up to 10 kg/hour (equivalent chlorine).

A V10k Gas Feeder system comprises the following three main items connected together by the injector suction pipeline:-

- 1 The gas control unit, which houses the flowmeter to give a visual indication of the gas feed rate; the V-notch plug unit used to control the gas feed rate and, a differential valve to maintain the vacuum differential across the V-notch plug.
- 2 The remote mounted aspirator type injector, which is connected into a suitable water supply and used to create the systems operating vacuum.
- 3 The vacuum demand valve, which fits to the gas cylinder or header valve and opens on demand (i.e. when a vacuum is applied to it) to allow gas into the injector suction pipeline.

Operation of the V10k is controlled by starting and stopping the flow of water through the injector. The gas feeder can be used in conjunction with either a standard injector or an anti-syphon injector.

Gas feed rate is controlled by varying the position of the V-notch plug. This is done either manually or automatically. Automatic control operates in conjunction with either a flow proportional signal, a measured residual signal or a flow and residual signal.

1.1 Principle of Operation (Fig.1)

When operating water flows through the V10k's injector a vacuum is created which fills the injector suction pipework. This vacuum pulls on the diaphragm of the vacuum demand valve causing the valve to open. Gas enters the suction pipework passing through the flowmeter - where the feed rate is indicated - and the V-notch variable orifice - where the feed rate is controlled - and into the injector. Here the gas mixes with the injector operating water and the solution passes into the delivery pipe line.

If the injector operating water is stopped, the vacuum breaks down, the demand valve closes and the flow of gas is shut-off.

During operation, if a leak develops in the vacuum pipeline between the injector and the vacuum demand valve, air is drawn into the pipeline preventing gas from escaping into the atmosphere.

A vacuum demand valve equipped with a pressure relief system is available. Should the demand valve fail to close when the injector is shut down, any gas pressure that builds up in the body of the valve will unseat the relief diaphragm and enter the vent line.



WARNING: The V10k gas feeder is designed to operate under vacuum only, and must, under no circumstances, be presented with gas above atmospheric pressure.

1.2 Gas Feeder (Fig.2)

The V10k Gas Feeder comprises a chemical resistant, one piece moulded headblock fitted with a differential regulating valve, a divergent tube flowmeter, a variable orifice V-notch plug assembly and a vacuum gauge. The assembly is fitted with a front cover.

Gas dosage is controlled by moving the V-notch plug in/out to varying the size of the orifice in which it fits. The vacuum across the V-notch orifice is kept constant by the differential valve. Movement of the V-notch plug to change the gas dose rate, is done either manually or automatically.

Manual Dosing Control:

Manual dosing is controlled by winding the control knob, on the underside of the gas feeder, anticlockwise (outwards) to increase the dosing rate or clockwise to decrease the dosing rate.

Start/Stop Dosing Control:

Start/Stop dosing is controlled by using either a solenoid operated water shut-off valve or a water booster pump to supply motive water to the injector.

Automatic Dosing Control:

Automatic dosing is controlled by varying the position of the V-notch plug in its orifice, using an electric reversing motor. The motor and its associated printed circuit card are housed in a separate enclosure and fitted, with the gas control unit, onto a wall mounted backplate. The signal from an electronic controller (supplied separately) is used to switch the reversing motor on/off in the appropriate direction to achieve the correct dosing requirement.

Three forms of control system are commonly used:-

FLOW CONTROL - in a flow control system a flow proportional signal (such as that provided by a W&T Signal Conditioning Unit (SCU)) is used to drive the plug positioner motor in the appropriate direction.

RESIDUAL CONTROL - in a residual control system a measured residual signal (such as that provided by a W&T Process Control Unit (PCU)) is used to drive the plug positioner motor in the appropriate direction for correct dosing.

FLOW AND RESIDUAL CONTROL (compound loop) - in a flow and residual control system a combination of the two signals described above (such as that provided by a W&T Process Control Unit), is used to drive the plug positioner motor in the appropriate direction.

The plug positioner drive is disengaged by pulling out the knob on the front panel of the positioner housing. Once the drive is disengaged the knob is turned manually for dosing control (e.g. in case of failure of the automatic control system). To return to automatic control push the knob back in, turning it slightly to allow it to engage the drive.

1.3 Injectors

Standard Injectors (Figs.4 and 6)

The standard injector used with the V10k Gas Feeder is a fixed throat, aspirator type unit which is available in two ranges; the 25mm Type U.96273 injector for gas capacities up to 15 kg/hour and the 19mm Type U.96275 injector for gas capacities up to 5 kg/hour. The injectors are fitted with check valves to prevent a back flow of water into the gas feeder if the injector is subject to positive back pressure when it is shut down or if the solution discharge line becomes blocked.

Anti-syphon Injectors (Figs.5 and 7)

The anti-syphon injector versions of both the 19mm and the 25mm injectors are basically as described above but are fitted with a second, spring loaded, diaphragm assembly to provide a positive shut-off against negative back pressure at the injector.

Both the standard and anti-syphon injectors are mounted remotely from the gas control unit.

1.4 Vacuum Demand Valve

The vacuum demand valve is to ensure that gas can only flow, from the storage cylinder or drum, into the gas supply pipelines when those pipelines are under the vacuum created at the injector.

Two versions of the vacuum demand valve are available. A non-switchover version for single cylinder operation and a switchover version for two cylinder operation.

The vacuum demand valve designed for automatic switchover is fitted with a mechanical detent. Moving the valve's control knob to the 'stand-by' position (see Section 1.4.1 below) sets the detent in its latched position. This version of the valve is used for dosing systems that are arranged for duty and stand-by operations.

When a duty and stand-by system is running the first vacuum demand valve feeds gas until its respective cylinder is depleted (at approximately 1 bar g) causing an increase in the vacuum to a higher than normal level. This provides sufficient force to unlatch the detent of the second unit. This valve then opens and takes over the gas supply function. The first cylinder can then be replaced and its vacuum demand valve reset for stand-by mode.

1.4.1 Valve Front Cover

The Front Cover of the demand valve houses the valve control mechanism and is provided with symbols which indicate the operating condition of the unit as follows:-

Non - switchover arrangement

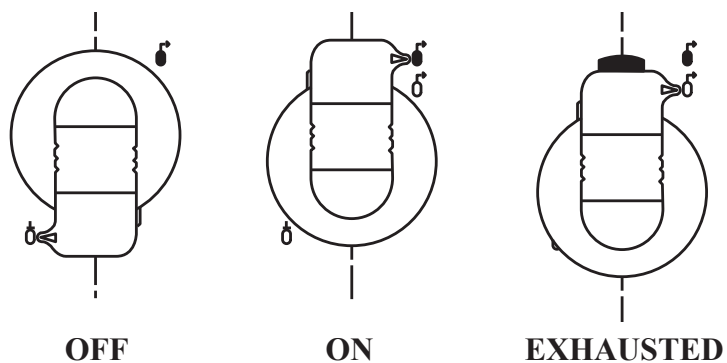

OFF (valve closed): indicated by an empty cylinder outline with a bar across its outlet pipeline to show that gas is prevented from flowing.

ON (valve open): indicated by a shaded-in cylinder outline with the bar removed to allow gas to flow through the supply pipeline.

EXHAUSTED (valve open but cylinder empty): indicated by an empty cylinder outline with bar removed but no flow of gas in the supply pipeline. In this position a red OUT OF GAS warning indicator, located immediately above the top of the knob, is also uncovered.

Switchover arrangement

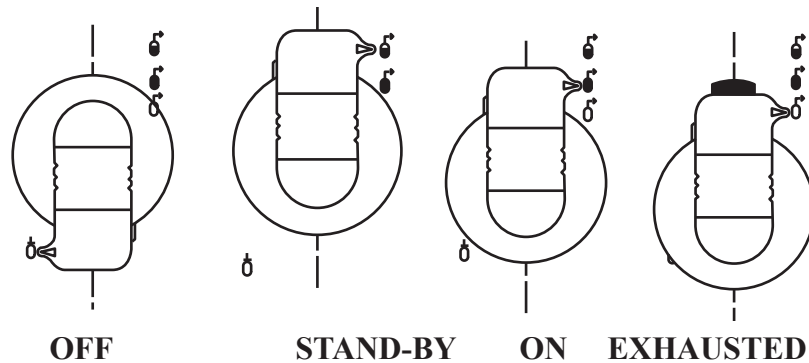

OFF (valve closed): indicated by an empty cylinder outline with a bar across its outlet pipeline to show that gas is prevented from flowing.

STAND-BY (supply available but valve still closed): indicated by a shaded-in cylinder outline with a bar across its neck and no gas in the supply pipeline. This shows gas is available but the outlet pipeline is closed until the gas pressure in the duty cylinder falls to the preset level causing the changeover mechanism to operate.

ON (valve open): indicated by a shaded-in cylinder outline with the bar removed to allow gas to flow through the supply pipeline.

EXHAUSTED (valve open but cylinder empty): indicated by an empty cylinder outline with bar removed but no flow of gas in the supply pipeline. In this position a red OUT OF GAS warning indicator, located above the knob, is also uncovered.

1.4.2 Front Housing

The front housing contains the diaphragm assembly and control mechanism. Fixed in the centre of the diaphragm is the operating shaft which connects at its top end, via the operating lever, to the control knob. As the control knob is moved to the required setting so the operating shaft positions the diaphragm for the corresponding operation. The operating shaft is also threaded which, when the control knob is manually turned clockwise or anticlockwise will move the diaphragm into its locked or unlocked position.

1.4.3 Back Housing

The back housing of the vacuum demand valve is fitted with two check valves, the first in a nipple which is screwed into the housing of the second check valve. When the operating vacuum is present the diaphragm is pulled away from its seat and gas is allowed to enter the vacuum

pipework. If the operating vacuum is lost for any reason, the diaphragm will retract under spring pressure and shut-off the gas.

1.4.4 Pressure Relief

The pressure relief valve fits into a recess in the back housing of the demand valve. The relief valve comprises a diaphragm, plunger and spring.

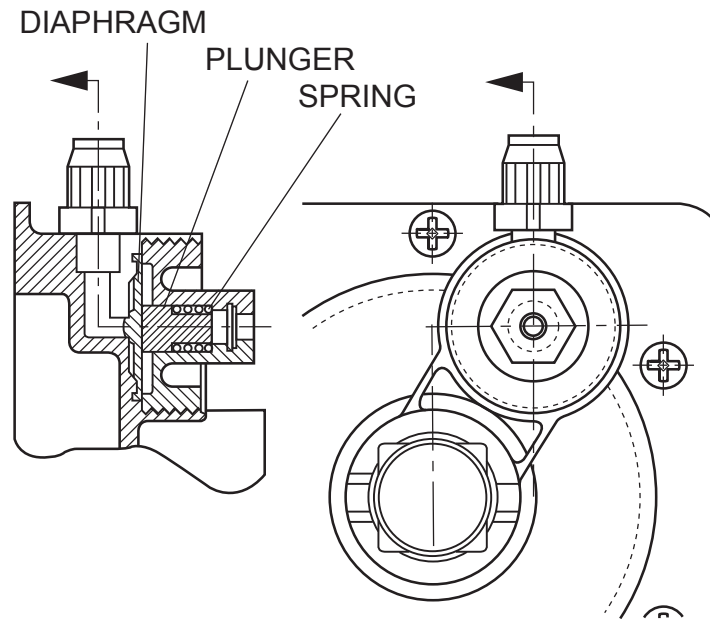

The face of the diaphragm is spring loaded against two openings, one opening connects into the main chamber of the valve and the other connects to the vent line.

Should the demand valve stems fail to seat when the operating vacuum is shut off, gas will pass into the main chamber of the valve where its pressure acts against the underside of relief valve diaphragm at the first opening. The relief valve diaphragm is forced against its spring until it unseats at which point gas is allowed to pass through the second opening and into the vent line.

1.4.5 Yoke Assembly (Fig.10 and 11)

The vacuum demand valve is supplied with a yoke assembly which enables the valve to be mounted directly onto a gas cylinder or a wall mounted header valve.

1.4.6 Heater (optional)

An optional, bolt on heater assembly is available for installations where reliquefaction of the gas within the valve is a problem due to low external temperatures. This unit comprises a small 110v or 230v, mains operated heater capsule which locates in a cavity in the main body of the valve.

The heater is temperature controlled by a thermostat clamped into a recess in the side of the valve body.

1.5 Vacuum Switch (optional)

As an optional fitting, the vacuum demand valve can be supplied with one of two types of vacuum alarm switch. A single function vacuum alarm switch fitted inside the valve or a dual function vacuum alarm switch which is mounted external to the valve.

1.5.1 Single function vacuum alarm switch (Fig.8)

The optional single function vacuum alarm switch, is fitted with a single volt free contact which is used to signal LOSS OF GAS when insufficient injector suction is detected.

The switch is located adjacent to, and operated by, the valves vacuum indicator. If the vacuum indicator goes to the red OUT OF GAS position, its volt free contact will make to initiate an external alarm or to control the operation of an associated item of equipment.

1.5.2 Dual function vacuum alarm switch (Fig.9)

The optional dual function vacuum alarm switch is mounted on a wall adjacent to the gas control unit (or a back plate if used with an automatic gas feeder) and connected to the gas control unit via a ptfе tube. It detects the level of vacuum being drawn through the V-notch plug and if this level increases to above – 60 in H₂O the volt free 'GAS FAILURE' contact will operate. If the level of vacuum drawn falls to below – 8 in H₂O then the volt free 'VACUUM FAILURE' contact will operate.

1.6 Technical Data

Accuracy of dosage	± 4% F.S.
Operating temperature	10° C to 50° C
Operating vacuum	40 - 200 mbar (green sector on manometer)
Operating water pressure at the injector	max. 21 bar at 20°C max. 13 bar at 30°C max. 10 bar at 40°C max. 5.9 bar at 50°C
Positioner details:	
Mains supply	230V 50 hz, 19 mA 115V 60 Hz, 46 mA
Time 0-100%	80 sec (50 Hz), 66 sec (60 Hz)
Potentiometer	1 kOhm ± 10%
Flowmeter capacities:-	0.06 - 15 kg/h (equivalent chlorine)

2 INSTALLATION



WARNING: To avoid possible severe personal injury or damage to plant this equipment should be installed, operated and serviced only by trained qualified personnel who are thoroughly familiar with the entire contents of this instruction book.

2.1 Unpacking the Equipment



CAUTION: Some equipment is despatched with temporary plugs fitted to the open ports/connections that come into contact with gas. These plugs prevent the ingress of moisture and must be left in place until the equipment is installed. Retain the plugs for use when the item is removed from service for maintenance purposes.

Unpack the equipment in a clean, dry area, preferably at the installation site. Open the packing only on the upper side. Take the accessories out of the cardboard pocket above the chlorinator. Holding the chlorinator at the mounting plate or at the positioner, NOT at the red valve shaft or the positioner rack, lift it out of the packing case.

To prevent damage during transport the glass tube flowmeter is packed separately. Handle this glass tube very carefully. Cracks make the glass tube useless. Check all items against the packing note to ensure that none is discarded with the packing materials.

2.2 Location Requirements



CAUTION: To avoid personal injury by chlorine gas, install the equipment so that in case of a fault, chlorine gas may escape within the storage room only. Those parts of the chlorine system subject to gas under pressure (such as tanks, reducing valves, relief valve, vent line) should be installed in the storage room only. Refer to the national or regional regulations.

When selecting a location for the V10k, attention should be paid to the following requirements, placing emphasis on personnel safety.

- 1 An adequate supply of clean water should be available to operate the injector which should be located as closely as possible to the gas feeder.
- 2 To avoid reliquefaction of the gas in the supply line, the ambient temperature around the gas feeder should be at least as warm as that around the gas containers. The area should also be clean and dry and interconnecting pipework should always be routed so that it is not subject to draughts which would cause lower temperatures at specific points.

- 3 Gas containers are heavy and the location should be chosen to give the shortest possible gas supply line, consistent with safe handling of the containers.
- 4 Ensure the location is such that unauthorised persons can be excluded from the installation.
- 5 Adequate access should be available to permit ease of operation and maintenance of all plant items.

2.3 Installing the Gas Feeder

The Gas Feeder should be installed on a vertical surface, wall, etc. with the dowels and screws supplied loose. The flowmeter should be at a height suitable for easy reading and for easy removal from the front cover.

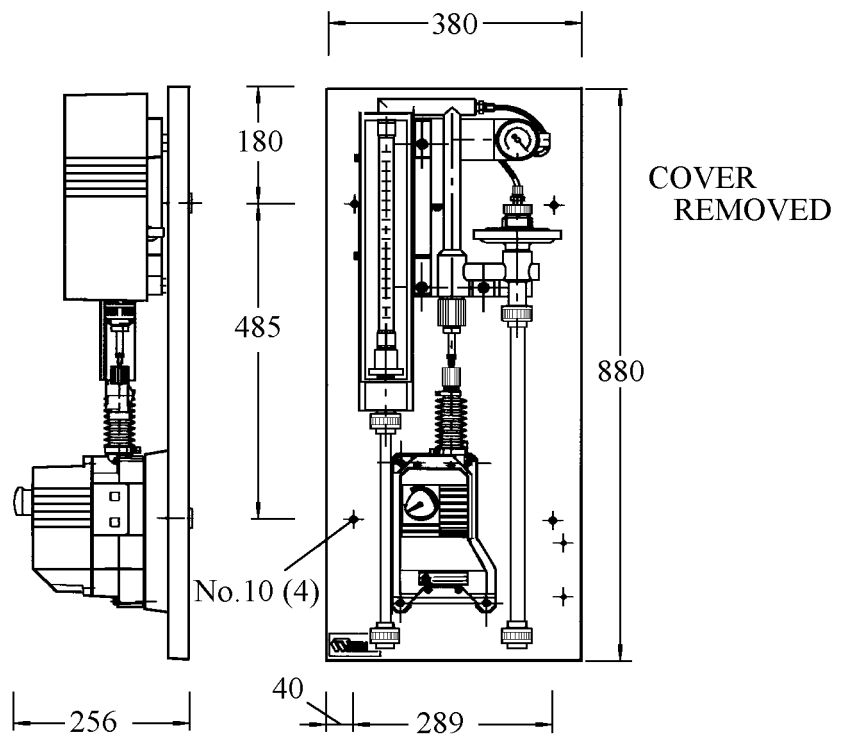

BZ 1277

The cover is removed by placing the thumb of the right hand on the manometer and pulling the cover at both sides at the same time. After mounting, slide the cover over the T - shaped rails of the body, then push evenly on the right and left hand sides until the cover is flush with the manometer and locked in position.

The preceding sketch shows the back plate dimensions for the automatic version of the V10k (other back plates 432mm and 580mm wide allow, respectively, the fitting of an injector and the fitting of a Signal Conditioning Unit to the backplate). Make sure the unit is level and doesn't distort when tightening the nuts.

2.3.1 Installing the flowmeter (Fig.2A)

NOTE: The flowmeter should only be fitted immediately prior to commissioning to avoid damage to the glass tube.

Apply some silicone grease to the two 'O' rings and place them into the grooves. Place the flowmeter tube onto the lower O-ring, the high values of the scale at the top, press down the lower seat with two fingers, if necessary press down the lower O-ring with the flowmeter tube, position the tube into the upper seat and slowly release the lower seat. Turn the tube until the scale is at the front.

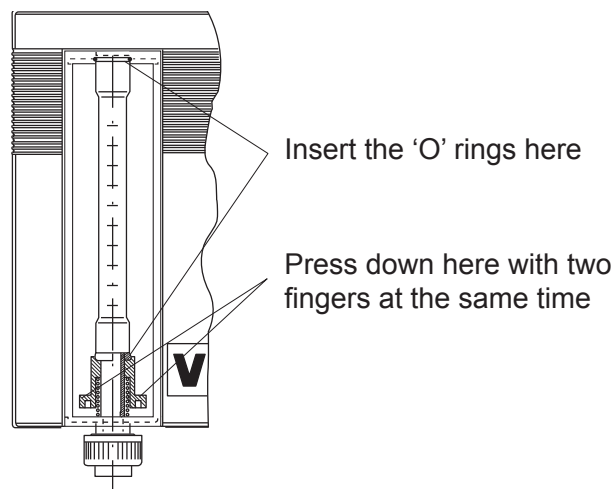

2.3.2 Adjusting the electric plug positioner

The electric plug positioner is tested and adjusted in the factory before despatch and should be ready to operate when installation and external wiring are complete. However, if the plug positioner needs adjusting turn to Section 4.7 of this manual for details.

2.4 Installing the Injector



CAUTION: DO NOT CUT OFF ANY PORTION OF THE TAILWAY, If rigid PVC pipe is used, the distance between the centre of the injector and the first downstream bend or component should be at least 1.0m for the injector to operate at maximum efficiency. This is known as the 'recovery length'.

When installed with rigid pipework the injector may not need additional support. However, if the injector is installed with flexible pipework the pipelines will need additional support and should be fixed according to the details shown in Fig 1.

The injector is installed in the operating water pipework in either the vertical or the horizontal position (if not already fitted to a mounting

plate). The nozzle (with stamped NUMBER) and tailway (with stamped LETTER) are supplied loose. Place the O-rings on both parts and apply some silicone grease.

When fitting nozzle and tailway to the injector body pay attention to the flow direction (see arrows on the body). **HAND TIGHTEN ONLY.** For measuring the injector vacuum a 1/4" connection is provided.

2.4.1 Injector U.96275 (Fig. 6)

Injector U.96275 is the standard unit for gas feeders that has a maximum capacity of 5 kg/hour. The vacuum connection accepts various sized flexible and rigid tubing (refer to Fig.16 for details).

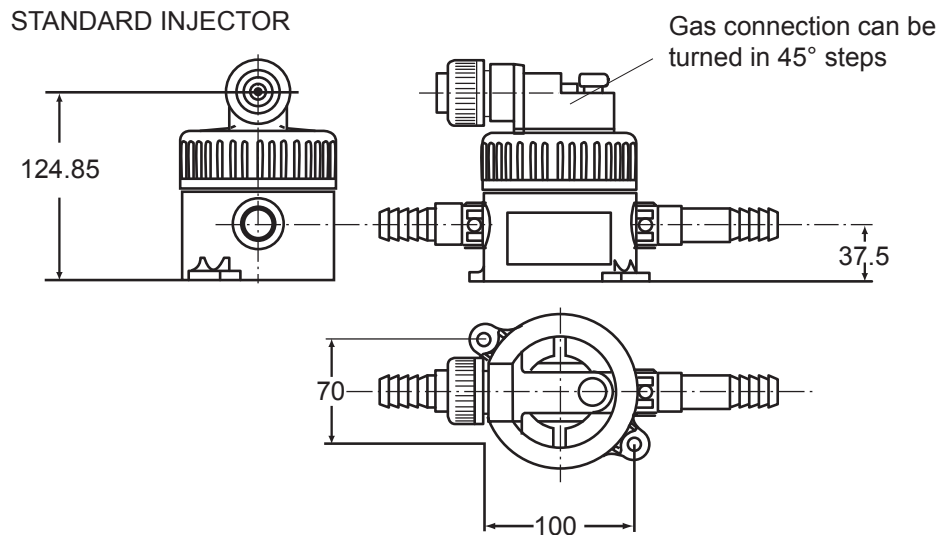

If 20mm rigid tubing is used, that part of the nozzle used for flexible tube is removed. The mounting holes are drilled to suit 6mm (1/4") fixings.

The gas connection can be turned in 45° steps to better match the direction of the vacuum pipeline. This is done by loosening the union nut until the connection can be moved but the notches at 45° spacing can just be felt. Turn the connection until it clicks into the desired position and, ensuring that it mates correctly, tightening the union nut. Tighten only by hand.

2.4.2 Injector U-96273 (Fig.4)

Injector U.96273 is the standard 25mm (1") injector supplied with gas feeders that have a capacity ranging from 5 kg/h to 15 kg/hour.



CAUTION: DO NOT CUT OFF ANY PORTION OF THE TAILWAY, otherwise the flow in the pressure-recovery zone will be interrupted and prevent normal performance.

The gas connection for the 15 kg/hour injector can be turned in 60° steps to provide, if required, a more suitable angle of connection to the vacuum pipeline. This is done by removing the 6 bolts in the top cover and turning it until it mates with the notch in the injector body that is closest to the desired position. With the cover correctly positioned, evenly tighten the 6 bolts. The mounting holes are suitable for 6mm (1/4") fixings.

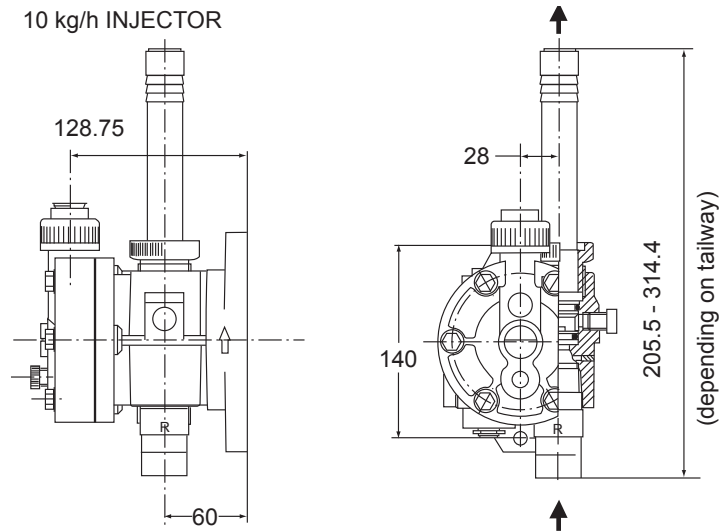

2.4.3 Anti-syphon Injectors (Figs.5 and 7)

NOTE: An anti-syphon injector is used where the solution delivery pipeline is subject to the syphoning effect caused by negative head conditions at the point of application. Both the 19mm and the 25mm injectors described above are supplied in anti - syphon versions. Refer to the illustrations at the back of the manual for their part numbers.

2.5 Point-of-application

If the point-of-application is a pressurized main or is higher than the injector, a suitable pipe tapping is required. The solution line should incorporate a check valve and terminate in a solution injection tube and corporation cock assembly.

Beyond the point-of-application a pipe length of at least 10 to 15 x the pipe diameter is necessary for homogenous mixing of the solution with the main water. Beyond this point, samples can be taken for residual control purposes etc.

If the point-of-application is into a basin, channel etc. with negligible pressure, the line need only be supported so that its free end is adequately submerged (a minimum 150mm) and located in a non-stagnant area. This type of installation may require an anti-syphon injector (see Section 2.4.2).

2.6 Water Supply and Solution Delivery Pipelines



WARNING: It is recommended that all solution delivery lines be fitted with a suitable valve and drain pipe to enable any pressure build up to be safely released prior to maintenance work commencing.

Each installation is designed to suit the particular site operating water characteristics, details of which are considered at the quotation stage. If the operating water conditions change, it may be necessary to change the existing nozzle/injector throat and/or tailway to obtain optimum efficiency. If this is thought to be the case, we recommend that reference be made to Evoqua Water Technologies.

The water line should include a suitable shut-off valve and a strainer.

Care must be taken to ensure that the type of hoses, pipes and the method of securing them are compatible with the pressure concerned.

2.7 Installing the Vacuum Demand Valve



WARNING: When the equipment described in this manual is used with carbon dioxide then, pressure regulators, reducing valves, pressure relief valves and all related pipework and fittings between the gas supply and the vacuum demand valve, must be obtained from the gas supplier; they must be installed in accordance with his recommendations. (Drawings and text in this book are not applicable to carbon dioxide systems). Gas supply pressure must be reduced to between 1.4 and 15 bar g to prevent over-pressurization of the vacuum demand valve. A pressure relief device, set at a maximum of 15.8 bar g should be installed between the pressure reducing valve and the vacuum demand valve.

Piping for chlorine (or sulphur dioxide) gas supply, where the chlorine (or sulphur dioxide) is under pressure, should conform to the recommendations of ICI, the Chlorine Institute (or Compressed Gas Association) and the Health and Safety Executive. Plastic tubing and pipe are not recommended and should not be used.

When threaded joints are used, take extreme care to obtain clean, sharp threads. Use Loctite, or proprietary jointing compounds, for permanent joints.

2.7.1 Cylinder mounting (Figs.10 & 11)

When mounted on a gas supply cylinder, the vacuum demand valve is connected to the cylinder valve by a yoke arrangement. The cylinder must be vertical with the cylinder valve on top.



WARNING: To avoid gas leakage and severe personal injury or equipment damage, always use a new lead gasket when installing a vacuum demand valve and every time a supply cylinder is changed.

If the system is composed of only one vacuum demand valve, when its associated cylinder is depleted, a full cylinder is put in place and the unit is reconnected.

In the following sketch a duty and standby gas supply system is illustrated. Two demand valves, arranged for automatic switchover, are employed. The duty valve will feed gas on demand until its cylinder is depleted (at approximately 1 bar). As the gas pressure falls the vacuum suction increases until it unlatches a mechanical detent in the second valve causing it to open. The full stand-by cylinder then comes into service. The depleted cylinder is replaced (see Section 3.3). Upon depletion of the second cylinder the switchover cycle is repeated.

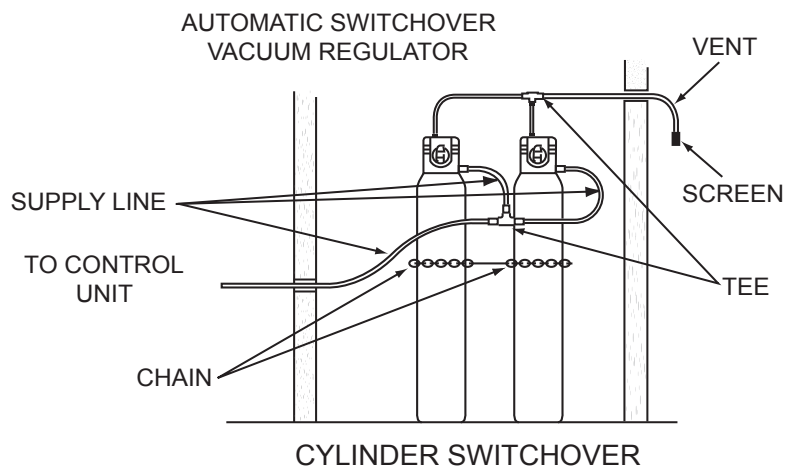

2.7.2 Header mounting (Fig.16A & 16B)



CAUTION: When a vacuum demand valve is connected to a gas header manifold, the manifold pipework must run at a level below that of the demand valve in order to prevent re-liquifying gas from settling in the valve. If necessary install a drip leg or similar trap.

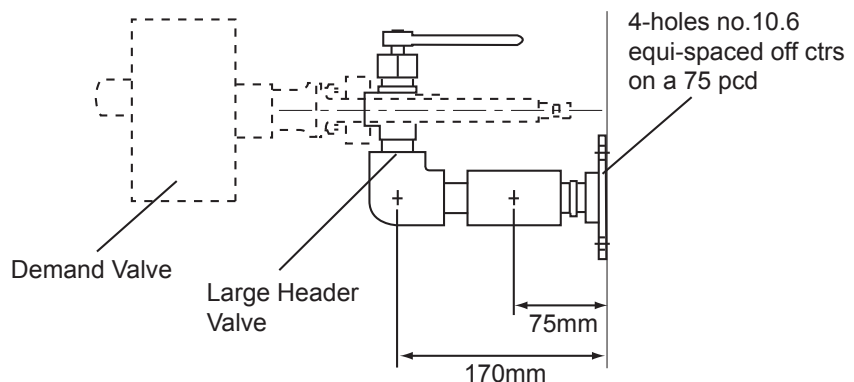

Typical Header Wall Fitting

The above sketch shows a wall mounted unit for a single demand valve, but as many as eight demand valves can be fitted to a single prefabricated manifold connected to a single gas cylinder. Alternatively six cylinders

can be connected to a manifold fitted with a single demand valve. Any single valve wall unit or multi-valved manifold can be supplied fitted with a gas pressure gauge. See Fig.17 for further information.

2.7.3 Safety vent line

As a matter of policy Evoqua Water Technologies recommend that wherever practicable the safety vent line should be run to a gas tight room, preferably containing an automatic shut off system. The vent lines should be terminated in an absorbing carbon filter. The contents of the carbon absorber should be replaced, as a matter of routine maintenance, every six months during normal operation and immediately after a major venting incident.

If it is not possible to vent into the room then the following recommendations are made:



WARNING: The vent lines should be terminated in a designated safe area. Do not terminate the safety vent line in areas frequented by personnel - external work areas, footpaths etc., or adjacent to windows or ventilation system intakes. The line must be run on a continuous down gradient, without low traps, to a point outside the building, and not exceed 10 metres in length. Where traps are unavoidable or a down gradient is not possible, provision for condensate removal (i.e. drip leg) must be installed at low points. See Section 4.5 for vent line disconnection.

The vent line should be supported over its entire length. The free end must be turned down to prevent the ingress of moisture and dust and a wire screen placed over the end to prevent the entry of insects and the possible blockage of the line. It is recommended that a suitable warning notice be affixed adjacent to the vent outlet, e.g. '**WARNING - CHLORINE FUMES**'.

2.7.4 Suction pipeline from vacuum demand valve to gas feeder (Fig.15)



WARNING: The gas feeder must only be connected to a vacuum pipeline. Do not open the cylinder or drum valve until the system has been fully installed and the pre-start checks in Section 3.1 are being carried out.



CAUTION: Polythene pipe lines become brittle under the influence of chlorine and they should not be installed in narrow, badly vented protection pipes or in the ground as this action could hasten the process.

The following table shows the maximum length of pipe run, in metres, that can be used between its supply cylinder and a chlorinator for a given chlorine feed rate.

TYPE V10k GAS FEEDER

Flowrate: 200 400 1000 2000 3000 4000 6000 8000 10000 g/h

Flexible plastic tube 3/8" x 1/2" (RP.68-4484):	>300	>300	100	25	10	6	-	-	-	m
Flexible plastic tube 1/2" x 5/8" RP.68-4502:	>300	>300	>300	130	110	38	18	11	7	m
1/2" nb rigid pvc:	>300	>300	>300	>300	250	110	50	31	21	m
3/4" rigid pvc :	>300	>300	>300	>300	>300	>300	162	96	64	m

2.7.5 Suction pipeline from gas feeder to injector (see Fig.15)

The following table shows the maximum length of pipe run, in metres, that can be used between a chlorinator and its injector for a given chlorine gas feed rate.

Flowrate: 200 400 1000 2000 3000 4000 6000 8000 10000 g/h

Flexible plastic tube 3/8" x 1/2" (RP.68-4484):	>300	>300	200	50	20	12	-	-	-	m
1/2" nb rigid pvc tube:	>300	>300	>300	>300	300	200	100	-	-	m

2.8 Electrical Connections



WARNING: Mains voltage can kill. To avoid personal injury by electrical shock only authorized and qualified electricians may carry out work on electrical parts of the system. Before removing covers to the stroke positioner, vacuum switch or electronic control unit, ensure the mains supply to the unit is switched off.

The automatic V10k Gas Feeder is fitted with an electric plug positioner for use with the Wallace & Tiernan Signal Conditioning Unit (flow proportional control) or the Process Control Unit (residual or compound loop control).

2.8.1 Mains supply

The plug positioner will require either a 120V ± 10% (200mA) or a 230V, ± 10% (100mA), 50/60 Hz, single phase supply which is fed, via its printed circuit card, to the reversing motor and is switched on/off from a remote mounted electronic controller.

The increase/decrease connections are made to the following terminals:-

INCREASE	-	L1 MAX
DECREASE	-	L1 MIN
EARTH	-	L2 N

Refer to the wiring diagram 30-E-7662 shown at Fig.18.

To gain access to the plug positioner remove the control knob (2mm Allen key), lift the lateral brackets and pull the cover away.

Make sure that the gear case of the positioner is safely connected to the earth stud.

In order to isolate the positioner from the mains supply during service or repair, install a 2 pole switch between the electronic controller and the positioner not far from the positioner.

Movement direction:	ZU/DEC	connecting rod moves out, chlorinator flow decreases,
	AUF/INC	connecting rod moves in, chlorinator flow increases.

2.8.2 Single and dual function vacuum alarm switches (Figs. 8 and 9)

The single function vacuum alarm switch is fitted with flying leads when supplied, to enable its volt free alarm contacts to be connected to the associated alarm system.

For use with a manual gas control unit the dual function vacuum alarm switch is supplied as a loose item and should be mounted on a wall as close to the gas control unit as possible. The centres of the four locating holes being 80 mm horizontally and 70 mm vertically. The switch should be located as close as possible to the gas control unit and connected to it with a length of the correct diameter tubing.

The leads from the remote alarm system are connected to the switches terminals with access to the terminals gained by removing the switch cover (refer to the wiring diagram shown on the following page).

NOTE: With the standard vacuum switch arrangement the micro switches, rated at 5 amps, 240V/1ph/50Hz supply, are wired so that with a healthy vacuum present the 'VACUUM FAILURE' contact is Normally Open (N/O) and the 'GAS FAILURE' contact is Normally Closed (N/C).

TYPE V10k GAS FEEDER

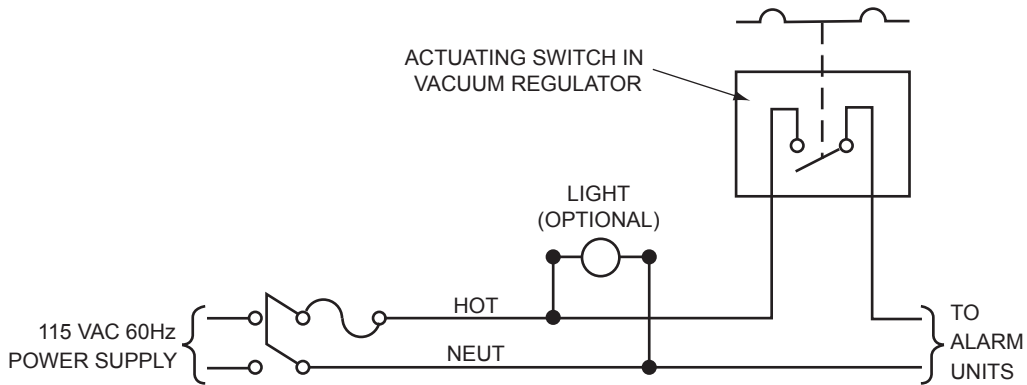
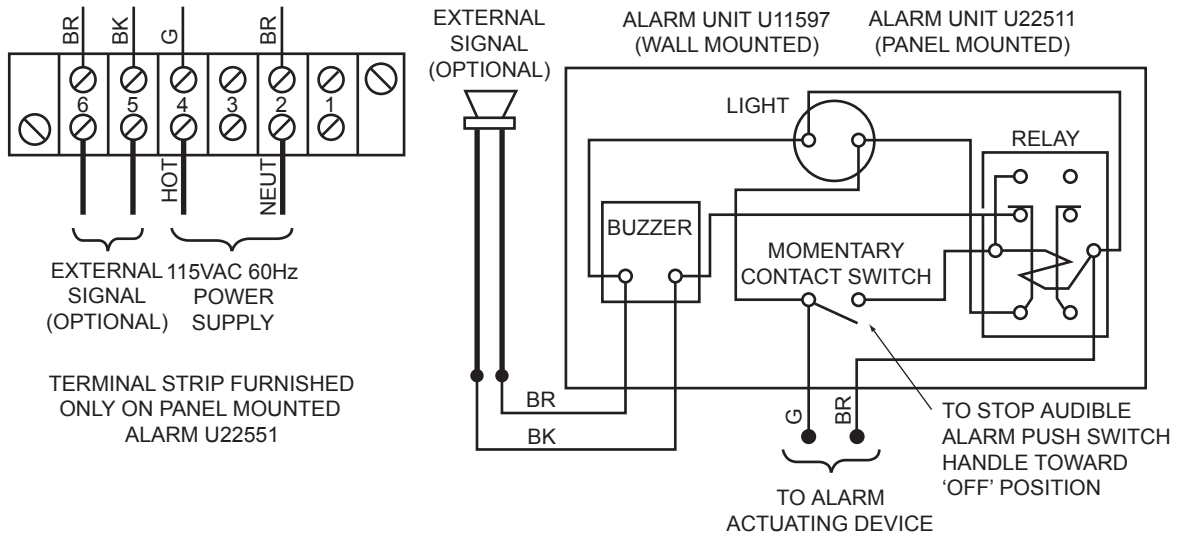

NOTE: Wiring by W&T
 Field wiring (not W&T) must conform to local electrical codes

3 OPERATION

3.1 Preparation for Initial Operation

When all the connections in Section 2 have been made, the following pre-start checks must be carried out before the plant is placed in service.

3.1.1 Physical check

- 1 Ensure the gas supply lines from the cylinders or drums are securely connected and that all valves in the system are closed.
- 2 Check that the water inlet line from the source of supply to the injector is securely connected.
- 3 Ensure the safety vent line is securely connected to the vacuum demand valve and that it terminates correctly outside the building.
- 4 Ensure the injector gas suction line is correctly fitted to the feeder gas outlet and to the injector.
- 5 Check the solution line from the injector to the point-of-application. If the point-of-application is into a main through a corporation cock, the cock must be opened and the tube pushed in as far as possible and secured on the bayonet fitting.
- 6 Check the installation of any accessories fitted. Ensure the check valve is fitted correctly (the arrow indicates the direction of flow); ensure a drain line is fitted to the anti-siphon valve, terminating above a suitable drain.

3.1.2 Injector vacuum leak check

- 1 Keep the valves on the chlorine tanks closed. Open the valves in the water supply line to the injector and at the point-of-application. Check for leaks.
- 2 Check the flowmeter. Any movement of the float off its stop indicates an ingress of air at one of the following locations:
 - through the safety relief valve
 - through the 'O' ring on the bottom of the flowmeter
 - through cracks in the flowmeter
 - through the O-rings at the pipe connections
 - through incorrectly made pipework joints or slack unions

3.1.3 Gas supply leak check



WARNING: In the following procedure, chlorine gas is introduced into the system and all pressure joints are tested for leaks. It is recommended that breathing apparatus should be worn during the procedure!

NOTE: Testing for leaks of chlorine or sulphur dioxide gas is accomplished by introducing ammonia fumes to the area under test. A puffer bottle (W&T Part No.U86151), containing a 10% ammonia solution is used. Any escaping gas will combine with the ammonia to form dense white clouds of ammonium chloride.



WARNING: Before commencing this procedure, ensure that the injector associated with the gas control unit is operational, i.e. that the injector is operating correctly and can be started immediately a gas leak is detected. On automatically controlled units select the manual mode of operation. If a leak of gas is detected, close the storage cylinder or header valves and start-up the injector immediately. Open all other valves in the gas supply line, including the vacuum demand valve, to evacuate any gas from the system. Rectify the leak and re-start the procedure.

If the V10k is fitted with auto dosing control, pull out the knob on the front panel of the electric positioner housing to disengage the automatic drive. (When the gas leak test is completed and it is safe to do so, push the control knob back in and re-engage the drive).

- 1 Activate the gas warning device.
- 2 Ensure the vacuum demand valve is 'OFF' (slide knob down and turn clockwise) and all valves in the gas supply system are closed.
- 3 Ensure the auxiliary cylinder/drum valve is closed and crack open the cylinder/drum main valve. Test for leaks around the valve assembly as detailed in the NOTE above. If there are no leaks, open the cylinder/drum main valve one turn.
- 4 Open the auxiliary cylinder/drum valve and then close it again and test for leaks to the next valve in the system. If there are no leaks, fully open the auxiliary cylinder/drum valve.

3.2 Operating Procedures

3.2.1 To start

- 1 Open the point-of-application and the operating water valves. The V10k manometer needle should move into the green.
- 2 Open the gas supply valves.
- 3 On manual units unscrew the control knob until the flowmeter indicates the required gas feed rate.

- 4 On automatic units pull the control knob out, manually set the feed rate then push the control knob back into position.
- 5 Check that the dosage rate at the Electronic Controller (SCU, PCU etc.) corresponds to the indicated feed rate at the flowmeter. For further information see the instruction manual of the Controller.

If the chlorinator is installed and adjusted correctly, only the following measures are necessary during operation:

- Checking and adjustment of the dosage rate
- Daily check of the tightness of pipework connections
- Function check of the gas warning device
- Change the gas cylinders
- Clean the strainer in the operating water line.

3.2.2 To stop for short periods

Select 0% dosage rate at the Electronic Controller or pull out the knob on the positioner and turn it to '0' or shut down the injector operating water supply.

3.2.3 To stop for extended periods, for maintenance or repair



WARNING: In the following procedure, which must be carried out before any gas feeder servicing is undertaken, a gas line is to be disconnected with a possible release of gas. It is recommended that breathing apparatus should be worn during the procedure.

- 1 Isolate the vacuum demand valve from its gas supply (i.e. shut the main cylinder valve or the appropriate header valve for a multiple valve arrangement). Allow the gas feeder to continue to operate until the flowmeter float remains static on the bottom stop.
- 2 Slacken the connection between the vacuum demand valve and its gas isolating valve. Air is now drawn through the valve and into the system to purge any remaining gas.
- 3 After at least three minutes re-tighten the connection, shut off the vacuum demand valve and turn off the water supply to the injector. The manometer pointer should come down to 0.
- 4 Release any pressure build up in the solution delivery line (refer to WARNING in Section 2.6). If need be protect against frost by draining the water supply and solution delivery pipelines.

3.3 Changing Gas Cylinders



WARNING: To avoid possible severe personal injury or equipment damage, before changing cylinders personnel must be completely familiar with the appropriate gas manual and your local plant operating and emergency procedures. Gas cylinders must be secured (e.g. chained) to prevent their being knocked over.

When a cylinder is depleted, as shown by the red coloured 'OUT OF GAS' indicator on the front of the vacuum demand valve or by a scale showing depletion of contents, place a full cylinder ready for service. If the gas feeder is operating, the injector need not be shut off. If the system has two vacuum demand valves for automatic switchover, the in-use unit need not be shut off. Proceed as follows:

- 1 Bring a full cylinder to the point of use.
- 2 At the exhausted cylinder shut the main cylinder valve.
- 3 Turn the vacuum demand valve knob all the way to 'OFF'.



CAUTION: When any connection is broken even for a short time, immediately plug the resultant openings with a rubber stopper or equivalent to prevent the entrance of moisture.

- 4 Disconnect the empty cylinder from the supply line. If the vacuum demand valve is mounted directly on the cylinder, loosen the yoke screw and remove the valve from the empty cylinder. Rest the valve on any support surface or hang from a hook through the yoke.



CAUTION: Do not permit its weight to hang by the tubing. Unsupported, it may loosen or damage the tubing at the connectors.

- 5 Release the chain and move the depleted cylinder aside.
- 6 Move the full cylinder into place and secure the restraining chain. Check that the cylinder valve packing nut is tight.
- 7 From the supply line connection or vacuum demand valve inlet nipple remove and replace the lead gasket.

NOTE: Every three months, during a cylinder change, replace the mesh screen (Fig.11 (8)) and filter (10) fitted into the spring retainer (9) of the cylinder yoke nipple (7).



CAUTION: The mesh screen (8) must be inserted into the spring retainer (9) before the ptfе filter (10). If these items are placed in the wrong order the filter may be pulled into the valve by the vacuum.

- 8 Position the vacuum demand valve on the cylinder valve and tighten the yoke screw securely.
- 9 Check for leaks as detailed in Section 3.1.3.
- 10 Check the gasket joint and packing nut for leaks. Correct as indicated.



WARNING: To avoid possible severe personal injury or equipment damage, do not tolerate leaks. Leaks always get progressively worse and must be corrected promptly.

- 11 Open the cylinder valve approximately one turn.
- 12 After correcting any leaks, turn the vacuum demand valve to 'ON'.
- 13 Replace the depleted cylinder valve cap and hood, tear the tag (designating an empty cylinder) and move the cylinder to the storage area for empty cylinders.

3.4 Intermittent Start/Stop Operation

The gas feeder may be operated automatically in the start-stop mode by controlling the injector water supply with an electrically operated solenoid valve in the injector water supply line and connecting it so the valve is open when the booster pump is running and closed when the booster pump is shut down.

3.5 Electronic Controller

Instructions for the electronic controller (Process Control Unit or Signal Conditioning Unit) can be found in a separate instruction book supplied with the controller.

4 MAINTENANCE

Maintenance of the gas feeder is simplified if the following general precautions are taken. These are easily followed and will reduce costly maintenance and repairs by providing good operating conditions.

CHECK ALL CONNECTIONS DAILY - for signs of leaks. Every leak must be rectified as soon as it is discovered. Chlorine and sulphur dioxide gas, when moist, are extremely corrosive. All metal parts which normally come into contact with moist gas are made from materials which will withstand the corrosive action; common metals are used only where the part is exposed to dry gas.

The presence of a leak of chlorine or sulphur dioxide will be indicated by odour and/or fume detection equipment, if supplied. The exact location may be determined by ammonia vapour. Dense white clouds of ammonium chloride form near the leak in the presence of ammonia.

When a connection is broken, if only for a short time, the opening should be plugged immediately to prevent the ingress of moisture which should be excluded from any part of the equipment normally exposed only to dry gas.

Water leaks must not be tolerated and should be rectified as soon as they are discovered.

Whenever threaded plastic parts are assembled, silicone type grease should be used to prevent the parts locking together. In general, tools should not be used to make up plastic connections, this type of connection should be made up by hand only.

If the flowmeter tube, float, V-notch plug or any valve seat becomes contaminated with impurities sometimes found in gases, it should be removed and cleaned.

4.1 Cleaning the Parts



WARNING: All cleaning should be carried out in an open area or in a well ventilated room.

Most of the residue that accumulates can be removed with warm water and a detergent, rubber parts should be cleaned only with warm water and a detergent, followed by methylated spirits (if necessary).



WARNING: Carbon tetrachloride is a satisfactory cleaning agent however, The use of it is not recommend because of the possible toxic effect of exposure to its fumes. Do not use wood alcohol, ether, petrol or petroleum distillates.

All traces of solvent and moisture must be removed from parts which come in contact with the gas before they are returned to service. Do not use heat on plastic or hard rubber parts.

4.2 Preventive Maintenance Kits

Parts that have to be replaced are supplied in preventive maintenance kits. There is a standard kit for the following items (the gaskets are supplied in separate sets):-

Maintenance kits

Equipment	Set of gaskets	Recommended spares (1 year)
Chlorinator V10k	- W3T159881 (U.96362)	W3T292468 (U.96363)
Injector W3T171367 (U.96273)	- W3T167500 (U.96370)	W3T167501 (U.96371)
Injector W3T171367 (U.96274)	- W3T***** (U.96372)	W3T167502 (U.96373)
Injector W3T292467 (U.96275)	- W3T167496 (U.96366)	W3T292469 (U.96367)
Injector W3T171370 (U.96276)	- W3T167498 (U.96368)	W3T292470 (U.96369)

NOTE: Parts included in the kits can be replaced by competent personnel referring to the maintenance and safety instructions. Repairs going further may only be carried out by personnel specially instructed by Evoqua Water Technologies

Only use original Evoqua Water Technologies spare parts.

4.3 Maintenance of the Gas Feeder (Fig.2)

EVERY 12 MONTHS - the following maintenance procedures should be carried out at least once.

When removing O-rings: don't damage the faces they butt against. Apply a thin coat of silicone grease to O-rings and threads. Key numbers (shown in brackets) refer to the illustration at Fig.2.

- 1 Shut down the gas feeder as described in Section 3.2.3.
- 2 Remove the cover (see Section 2.3.1), and the flowmeter. Clean with warm water and detergent and soft cloth. Dry completely.
- 3 Replace O-rings (7). Remove base (12), replace the spring (13).
- 4 Undo the clamping nut (21), and use the control knob to drive the connecting rod downwards. Unscrew the V-notch plug assembly. Renew the extension chamber (17) O-ring.



CAUTION: If the V-notch plug is pulled outwards through the orifice the identification marks on the bottom of the plug will damage the orifice. The orifice should always be moved by sliding it over the top end of the V-notch plug.

- 5 Remove the seal clamping screw (18), unscrew the plug stem (19) from the V-notch plug.
- 6 Renew the shaft seal and the O-ring.
- 7 Remove the V-notch plug (15), orifice (16) and washer and clean. After 5 years renew the V-notch plug and the washer.
- 8 Where the plug assembly fits into the V10k body, the bore should be cleaned with warm water, detergent and a soft cloth. Dry completely.
- 9 Insert plug stem (19) with its O-ring, shaft seal, clamping screw and coupling into the extension chamber (17).
- 10 Hand tighten the seal clamping screw.
- 11 Place the washer onto the stud at the end of the plug stem (19) and screw on the V-notch plug.
- 12 Replace the orifice with the ring groove on the lower side.
- 13 Refit the plug assembly to the V10k body and reconnect the drive.
- 14 At the vacuum differential valve (see Fig.3 (1)), disconnect the vacuum tube, unscrew the plug (2) and replace its gasket.
- 15 Remove the valve body assembly (5). This should be renewed after 2 years.
- 16 Renew gasket (7) and spring (6).
- 17 Press out stem assembly (4) from above. Renew O-ring (3). Replace stem every 2 years.
- 18 Clean bore in the diaphragm with soft cloth.
- 19 Press stem back into its position.
- 20 Refit the valve body assembly (5); hand tighten only.
- 21 Replace the plug (2) and connect the tube to the manometer.
- 22 Renew the O-rings in the gas inlet (Fig.2 (14)) and gas outlet connections.
- 23 Reassemble all parts and check for tightness.

NOTE: The electric plug positioner is maintenance-free but some adjustment is obtainable - see Section 4.8.

4.4 Maintenance of the Injector

ONCE IN EVERY 12 MONTH PERIOD - the injector, whatever type is used, should be subject to the following maintenance procedure:-

The 'O' rings can be removed by using a needle and taking care not to damage the surfaces of the corresponding part! Apply some acid-free grease (silicon or vacuum grease or vaseline) to the new 'O' rings and to the threaded parts.

4.4.1. Standard 25mm injector U-96273 (Fig.4)

- 1 Shut down the gas feeder as detailed in Section 3.2.3 noting the WARNING in that Section.
- 2 Disconnect the vacuum tube from the injector and remove the solution delivery pipework as far as necessary for removing the tailway from the injector.
- 3 Unscrew the tailway (marked with a letter) and renew both of the 'O' rings. Refit and tighten again.
- 4 Loosen the 6 bolts (10). Remove the upper body (18) and put aside, the bolts still in the holes.
- 5 Remove diaphragm (19) with clamping nut (24), valve seat (17), O-rings (16 & 21) and spring (22).
- 6 Unscrew the clamping nut from the valve seat (17).
- 7 Renew the diaphragm, spring and O-rings (16 and 21). Every two years renew the valve seat (17), every 5 years renew the clamping nut (24).
- 8 Assemble diaphragm, valve seat and clamping nut, refit spring.
- 9 Renew O-ring (20). Refit the ball headed valve stem (14) and O-ring (13). Take care not to damage the ball head.
- 10 Place the diaphragm assembly with spring over the bolts of the upper body and press down into the lower body (23). Turn the gas inlet to face the desired direction and line up the bolt holes.
- 11 Insert the bolts and tighten equally.
- 12 Unscrew the plug (5) and renew the 'O' ring (6).

- 13 Remove the valve stem (11), renew spring (10) and O-ring (7). Every 2 years renew the valve stem (11).
- 14 Remove the plug (29) with large screw driver, renew 'O' ring (28).
- 15 Press out the valve seat (9) and fit a new one together with a new 'O' ring (8). Press home (to the stop) the new seat and 'O' ring using a square ended rod or plastic tube (16 mm dia). Take note that the seating is on the side of the plug (29)
- 16 Place the stem into the plug and screw the plug home. Check the stem for freedom of movement.
- 17 Screw in the plug (29) with its 'O' ring (28).
- 18 Renew the 'O' ring in the gas inlet.
- 19 Screw in the tailway and reconnect the solution delivery pipeline and the gas suction pipeline; check for tightness and function.

4.4.2 Anti-syphon 25mm injector U.96274 (Fig.5)

- 1 Shut down the gas feeder as detailed in Section 3.2.3.
- 2 Carry out Steps 1 - 11 as described in Section 4.4.1.
- 3 Unscrew the clamping nut (11) with the its connected parts.
- 4 Remove the valve stem (2), renew its 'O' ring. (Renew the valve stem itself every 2 years).
- 5 Remove the securing clip (13), clamping screw (11) and spring (12).
- 6 Remove the clamping disc (15) and renew 'O' ring (7).
- 7 Renew diaphragm assembly (4), and reassemble with clamping nut (11), spring (12) and secure with clip (13).
- 8 Remove plug (1) and renew its 'O' ring.
- 9 Remove the clamping nut (11) and press out the valve seat (Fig.4 (9)), taking note of the way it faces. Fit a new seat together with a new 'O' ring, pressing it home to the stop, using a square ended rod or plastic tube (16 mm dia).
- 10 Place the stem (2) into its guide and refit the complete diaphragm assembly into the valve body and secure with the clip (11).
- 11 Screw in the top plug (1).

- 12 Renew the 'O' ring in the gas inlet.
- 13 Refit the tailway and reconnect the suction and delivery pipelines.
- 14 Check for tightness and function.

4.4.3 Standard 19mm Injector U-96275 (Fig.6)

- 1 Shut down the gas feeder as detailed in Section 3.2.3.
- 2 Referring to Fig.6 disconnect the gas inlet, the water inlet and the solution outlet pipework as far as necessary for removing the tailway and nozzle from the injector.
- 3 Remove the tailway and nozzle and renew their 'O' rings.
- 4 Remove the inlet screw (3) and valve stem (7), renew O-ring (5) and spring (6). Every two years renew the valve stem (7).
- 5 Unscrew union nut (21), if necessary use a strap wrench, and remove the upper body (9).
- 6 Remove and discard valve stem (10). Fit new part ensuring the ball head is not damaged.
- 7 Remove diaphragm assembly (12, 18, 19)

NOTE: Two diaphragms are fitted to the injector, one made of Viton and one made of ptfe. It is important to ensure that they are fitted in the correct order with the Viton (AAA.4325) diaphragm on top (dry side) and the ptfe (P.97063) on the bottom (wet side).

- 8 Unscrew clamping nut (18) from the valve seat (12). Renew the diaphragm (19), 'O' rings (11 and 13) and spring (14). Reassemble the parts. Tighten very slightly.
- 9 Renew 'O' ring (20)
- 10 Place spring (14) on the clamping nut (18) and place together with the diaphragm assembly into the lower body (17).
- 11 Refit upper body (9) and union nut (21). Tighten very slightly.
- 12 Turn the upper body (9) until the gas inlet is positioned to line-up with the vacuum pipeline and tighten the union nut.
- 13 Refit the valve stem with its spring and O-ring , place O-ring (4) in position and refit the inlet screw (3).

- 14 Refit the nozzle (black with number) and tailway (white with letter). Ensure correct flow direction!
- 15 Renew the O-ring in the gas inlet union (2).
- 16 Reconnect the gas inlet line, the water supply and solution delivery pipelines and check for tightness and function.

4.4.4 Anti-syphon 19mm injector U-96276 (Fig. 7)

- 1 Shut down the gas feeder as detailed in Section 3.2.3 noting the WARNING in that Section.
- 2 Disconnect the gas inlet, water inlet and solution outlet pipework as far as necessary for removing tailway and nozzle from the injector.
- 3 The upper section of the anti-syphon injector is identical to the standard unit so carry out Steps 3 - 13 as described in Section 4.4.3.
- 4 Referring to Fig.7 unscrew the lower union nut (5), if necessary use a strap wrench.
- 5 Remove bottom cover (13) and spring (9).
- 6 Pull out the diaphragm assembly with guide pins (2), if necessary apply an even pressure equally on both pins from the opposite side of the valve body.
- 7 Renew O-rings (15).
- 8 Unscrew lower clamping nut (11) from the disk (3).
- 9 Renew the two diaphragms (7) and O-ring (6)
- 10 Assemble diaphragms with O-ring, disk and clamping nut. Every 5 years or when worn or stiff renew the pins (2). Remove the screws (14), place new washers (4), do not grease but apply some Loctite 242 to the thread. Tighten the screws, then slacken $\frac{3}{4}$ of a turn.
- 11 Renew O-ring (6).
- 12 Fit the spring (Fig.6 (14)) on its clamping nut and place together with the diaphragm assembly into the body (Fig.7 (1)).
- 13 Position upper body (Fig.6 (9)) and union nut (21). Tighten slightly.
- 14 Turn upper body until the gas inlet faces the desired direction, lock and tighten the union nut by hand..

- 15 Put together the valve stem and spring (Fig.6 (7 and 6)), position O-ring (5) and refit the inlet screw (3).
- 16 Fit the diaphragm assembly (Fig.7 (7, 9 and 11), disk (3) and pins (2) into the body (1).
- 17 Position spring (9) and bottom cover (13) and screw on lower union nut (5) by hand.
- 18 Screw in the nozzle (black with number) and tailway (white with letter), pay particular attention to the direction of flow!
- 19 Renew the O-ring in the gas inlet seat.
- 21 Reconnect the gas inlet, water inlet and solution delivery pipelines, check for tightness and function.

4.5 Maintenance of the Vacuum Demand Valve

Maintenance of this equipment must be restricted to trained, qualified personnel who are completely familiar with these instructions.

General precautions simplify maintenance and help to prevent equipment failure. These precautions are easy to accomplish and will minimise repairs by providing good operating conditions.

NOTE: If the gas feeder is used seasonally (long term shutdown) then the cleaning procedure should be performed prior to start-up.

Recommended Cleaning Interval for S10k Demand Valve:-

Operating experience is generally the best guide to when preventative maintenance operations should be carried out. The actual frequency will depend on calendar time, the feed rate and amount of gas fed, the care exercised in cylinder changing, the source of gas, and the quality of the operating water. In general Wallace & Tiernan recommend the following:-

Where the S10k is in continuous operation it should be serviced annually.

Where operation of the S10k is on a start/stop basis and is mounted on a cylinder it should be serviced every 6 months.

Evoqua Water Technologies recognise that servicing of the S10k is not, generally speaking, within the responsibility of the plant operator. To cover this we offer two options:-

- 1 Where customers prefer to carry out their own maintenance - training of personnel to a level whereby Evoqua Water Technologies will provide certification of their ability.

- 2 Where customers prefer to use manufactures personnel - a Evoqua Water Technologies Service Engineer can carry out the service.

NOTE: Reference should be made to either the separate S10k demand valve manual or the supplement at the back of this manual.



WARNING: To avoid possible severe personal injury or equipment damage, shut the gas supply container valve; evacuate all gas from the system and release any pressure in the solution discharge line as detailed in Section 3.2.4.

VALVE REMOVAL



WARNING: Any vertical section of the vent tube may contain chlorine gas/condensate.

- 1 Pinch the vent tube at its lowest point and then disconnect it from the demand valve.
- 2 Remove and plug the open end. If necessary clear the vent tube by blowing through it using an inert gas, or allow tube to drain/vent into room under controlled conditions.
- 3 Loosen the union nut and disconnect the vacuum tubing from the demand valve. Plug the tube with a rubber stopper to prevent the entrance of air and moisture while the demand valve is being cleaned.
- 4 Loosen the yoke screw and remove the entire vacuum demand valve to a location where the work is to be done. Cap the gas supply container valve outlet while not in use.

VALVE FITTING

- 1 Fit the vacuum demand valve to the gas supply container valve on which it is to be used. Use a new lead gasket on the inlet nipple and tighten the yoke screw securely.
- 2 Remove any temporary plugs and refit the gas vacuum line and the vent line to their respective connections.

4.6 Maintenance of Auxiliary Cylinder, Drum and Header Valves

The auxiliary cylinder, drum and small header valves are subject to rigid pressure testing at the time of manufacture but, as the ptfe packing in the valves is subject to 'cold flow', it is possible for valves held in stock for a long period to leak around the packing. If fitting a new valve, therefore, the tightness of the packing nut should be checked before the valve is placed in service.



CAUTION: The packing nut has a left-hand thread which means that the packing is tightened by turning the nut counter-clockwise. The length of the wrench used should not exceed 150 mm.



WARNING: Do not remove the packing nut whilst the valve is under pressure.

If necessary, the packing should be replaced as detailed below:-

AUX. CYLINDER & SMALL HEADER VALVES (Figs.12 & 16B)

- 1 Close the main cylinder valve and purge the gas line as detailed in the gas control unit instruction manual.
- 2 Remove the valve handle (1) (right-hand thread) from the valve stem (3) and valve body (5).
- 3 Remove the packing nut (Fig.12 (2)) and withdraw the stem and the packing (4).
- 4 Insert a new packing, replace the stem and lightly tighten the nut.
- 5 Engage the handle with the stem and valve body. The stem must seat before the handle covers all the threads on the valve body. Adjust the stem/handle arrangement so that only one thread on the valve body is visible when the valve is closed.
- 6 Tighten the packing nut.

AUX. DRUM AND LARGE HEADER VALVES (Figs.13 & 14)

- 1 Close the main drum valve and purge the gas line as detailed in the gas control unit instruction manual.
- 2 Remove the packing nut (9) and packing gland (2) from the valve body.
- 3 Using the wrench (1), remove the valve stem (7), packing ring (8) and packing (3) from the valve body.
- 4 Fit a new packing to the stem, insert the stem in the valve body, replace the packing gland and secure with the packing nut.



CAUTION: Do not over tighten the packing nut or it may be difficult to operate the valve.

4.6.1 Flexible connections

EVERY MONTH: check the flexible connections. Deterioration exists if a salmon pink colour develops on the end fittings (de-zincification due to a minute leak), if dents or kinks are present (which weaken the tubing) or if the tubing "squeaks" when it is handled (a sure sign of internal stress corrosion).

Your attention is directed to the Chlorine Institute's recommendation that:-

Flexible metal tubing connections used to connect supply cylinders to piping systems "**Should be replaced whenever there is a sign of deterioration but, in any event, at intervals no greater than annually**". Similar recommendations apply for other gases

This recommendation recognises the potential for mechanical damage to these connections in normal use as well as the possibility of reduced mechanical strength resulting from the corrosive effects of damp air entering the tubing during the process of changing cylinders.

Either of the above conditions can be difficult to detect and carries the potential for breakage and resultant chlorine (or other gas) leakage. A timely replacement programme can minimise this potential.

4.7 Adjusting the Electric Plug Positioner



WARNING: Mains voltage can kill! It is essential that the utmost care is taken when work is carried out on an open chassis where mains voltage is present. It is recommended that mains supplies are switched off whenever possible.

4.7.1 Checking the Positioner Motor

- Check the motor winding with an ohmmeter:
- Remove knob and screws, lift the cover
- Disconnect terminals 4/5/6
- Measure winding resistance (tolerance $\pm 10\%$ - if exceeded replace the motor)

Terminals	4-6	5-6	4-5
230-V-Motor	8500 Ω	8500 Ω	17000 Ω
115-V-Motor	1960 Ω	1960 Ω	3920 Ω

4.7.2 Replacing the rack

- 1 Isolate the plug positioner unit from the mains and disconnect rack coupling by undoing clamp nut (Key 1 on following sketch).

TYPE V10k GAS FEEDER

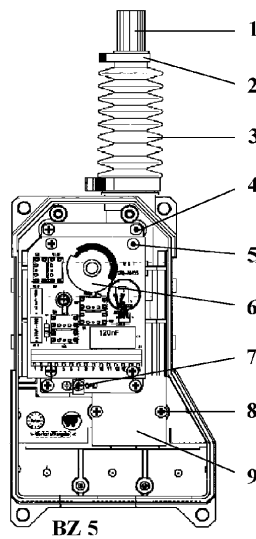

- 2 Remove the control knob and the positioner cover.
- 3 Remove all connectors at the board and disconnect the earth (7) from the gear.
- 4 Remove the 4 screws (5) and remove the motor-gear assembly including circuit board.
- 5 Remove the two screws (8) and remove the cover (9).
- 6 Remove the two clamps (2) and bellows (3).
- 7 Remove the Seeger circlip ring.
- 8 Pull out the rack, apply a plastic compatible grease to the new rack and refit it into the housing.
- 9 Replace the Seeger circlip ring on the rack and replace the cover.
- 10 Mount motor-gear-assembly with board, ensure the toothed wheel mates with the rack. Pull bellows over the rack and fix the clamps.
- 11 Select manual control by pulling out the control knob to disengage the drive and pull the rack down.
- 12 Fit the coupling to the chlorinator.
- 13 Connect the cables on the board and the gear to earth (4).
- 14 Adjust the limit switches and the potentiometer.
- 15 Close the cover and check for function.

4.7.3 Replacing circuit board

- 1 Disconnect the positioner from the mains.
- 2 Remove the control knob and the cover.
- 3 Remove all connectors from the board.
- 4 Remove cam wheel (6) use 1.5 mm Allan key.
- 5 Remove all 4 screws (5).
- 6 Remove the board with transparent cover.
- 7 Remove the toothed wheel from the potentiometer shaft.
- 8 Place the transparent cover onto the new board
- 9 Place the toothed wheel onto the potentiometer shaft, push to the stop and fix.
- 10 Fix the new board with the wheels matching
- 11 Replace the cam wheel.
- 12 Replace the connectors, adjust the limit switches and the potentiometer (Section 4.7.5), close the cover.
- 13 Check for function.

4.7.4 Replacing the motor gear assembly

- 1 Disconnect the positioner from the mains.
- 2 Remove the control knob and the cover.
- 3 Remove all connectors from the board and the ground
- 4 Remove screws (3)
- 5 Remove the motor-gear-assembly.
- 6 Remove the printed circuit board and fit the new motor gear assembly
- 7 Mount motor gear assembly ensuring the toothed wheel mates with the rack.
- 8 Refit the connectors, adjust the limit switches and the potentiometer, (Section 4.7.5), close the cover.

- 9 Check for function.

4.7.5 Adjusting the plug positioner

The electric plug positioner is tested and adjusted in the factory before despatch and should be ready to operate when installation and external wiring are complete. However, before starting the system after a major overhaul it is recommended that the following procedure is carried out to establish correct dose rates:-



WARNING: Mains voltage can kill! It is essential that the utmost care is taken when work is carried out on an open chassis where mains voltage is present. It is recommended the mains supply is switched off whenever possible.

Preparation

- 1 Switch off the mains supply to the positioner and to the limit switches and check to ensure that electrical isolation is complete.
- 2 Disengage the motor by pulling out the control knob.
- 3 Remove the knob (2 mm Allan key), unfasten the screws holding the cover, lift the side clips and remove the cover. Replace the knob or turn the knob shaft with a screw driver.
- 4 Remove the Allan key from inside of the cover for further use.

Adjusting the MINIMUM limit switch

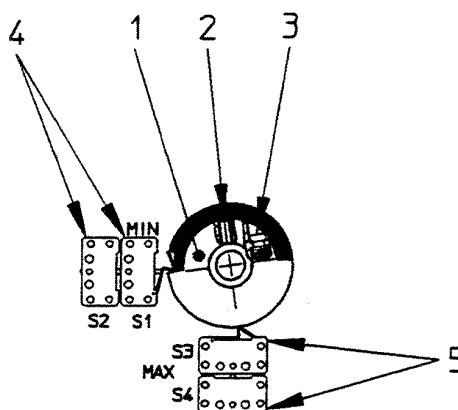

- 1 Move the connecting rod fully down and then 2 mm back.
- 2 Loosen the set screw (2) of the cam wheel (3).
- 3 Turn the yellow cam wheel until both MIN-limit switches (4) are switching.

- 4 Press the cam wheel to the stop and tighten the setscrew without turning the cam wheel.

Adjusting the MAXIMUM limit switch

- 1 Referring to the following sketch move the connecting rod fully in and then 2 mm back.

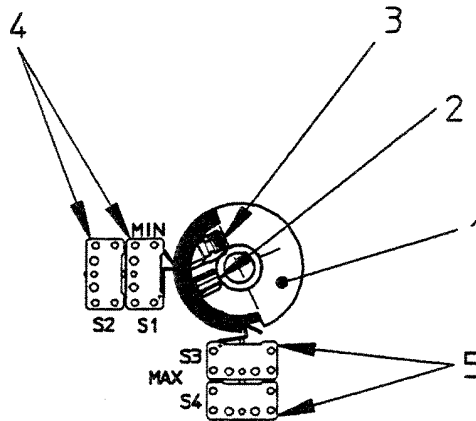

- 2 Turn the black cam wheel by turning the set screw (2) so far that both MAX switches (5) are switching. DO NOT LOOSEN or turn the whole cam wheel.
- 3 Check by moving the connecting rod.

Adjusting the feedback potentiometer

Adjustment is necessary, when a new board is mounted in the positioner or the motor gear unit has been removed or changed.

- 1 Open the cover (see preparation).
- 2 Disconnect terminals 13, 14, 15 (see wiring diagram Fig.18).
- 3 Move the connecting rod fully out to the stop.
- 4 Connect an ohmmeter to the terminals 13 and 14 on the board.
- 5 Loosen the great output tooth wheel on the shaft below the cam wheel.
- 6 Turn the tooth wheel until the ohmmeter displays between 10 and 30 ohm.
- 7 Lock the tooth wheel in position without turning it.
- 8 Move the connecting rod fully in to the stop.
- 9 Ohmmeter must display resistance smaller than the total resistance of 1kohm \pm 10%.

- 10 Check both adjustments by moving the connecting rod.
- 11 Remove the ohmmeter and reconnect terminals 13,14 and 15.
- 12 Remove the control knob, if mounted and replace the cover without damaging the shaft sealing.
- 13 Move the connecting rod fully out.
- 14 Refit the control knob and turn it so that the arrow points to the minimum setting and fix in position.
- 15 Re-engage automatic drive ensuring tooth wheels mesh.
- 16 Switch on and check for function.

4.7.6 Zeroing the V-notch plug for automatic dosing control (Fig.2)

To zero the V-notch plug for automatic dosing control first adjust the Electronic Controller until its output signal registers zero. Then:-

- 1 Shut down the dosing system, evacuate all gas from the vacuum pipework and release any pressure in the injector discharge line (see Section 3.2.3).
- 2 Pull out the control knob on the plug positioner (23) to disengage the drive and turn the knob to manually lower the drive shaft as far as possible.
- 3 Disconnect the drive clamping nut (21).
- 4 Unscrew the extension chamber (17) with the V-notch plug and keep the V-notch plug (15), stem (19) and orifice in position in the extension chamber.
- 5 Slide the plug in or out until the scribed line on the bottom end of the plug is level with the bottom of the orifice as viewed through the holes in the extension chamber.
- 6 Draw a pencil line, level with the bottom of the seal clamping screw (18), all around the plug stem.
- 7 When the parts are reassembled, this line may be used as a zero reference when the linkage is adjusted to match the zero of the electric actuator.

4.8 Fault Finding



WARNING: Before undertaking any fault finding operation which involves dismantling equipment, the system must be cleared of gas. Follow the procedure described in Section 3.2.3.

4.8.1 Gas feeder will not feed gas

CAUSE	REMEDY
Gas supply exhausted	Change gas cylinder
Gas supply turned off	Open valves
Solution tube clogged at poa	Open or clean both corporation cock and solution tube
Leakage in pipelines	Check if flow indicator goes to zero when gas supply is turned off. Check pipelines for leaks.
Insufficient injector vacuum	Check operating water pressure. Check pressure at poa (point of application)
Clogged injector	Clean injector parts
Clogged strainer in water supply line	Clean strainer insert
V-notch orifice clogged or worn	Clean or replace orifice
V-notch stem worn	Replace stem

4.8.2 Chlorine residual too low in spite of sufficient feed rate indicated

CAUSE	REMEDY
Air is pulled into the gas stream	Check for leaks upstream of the flowmeter including pressure relief valve.
Change and grease 'O' rings in flowmeter	
Increased chlorine demand	Check chlorine demand

4.8.3 Gas feeder will not run up to full capacity

CAUSE	REMEDY
Insufficient injector vacuum	See Section 4.8.1.
Injector does not meet requirements	Change injector parts

4.8.4 Flowmeter float moves erratically

CAUSE	REMEDY
Deposits on flowmeter parts	Clean flowmeter

4.8.5 Smell of chlorine in chlorinator room or vicinity

CAUSE	REMEDY
Pressure relief valve blown	Clean relief valve or replace unit

4.8.6 Water in flowmeter

CAUSE	REMEDY
Defective check valve in injector	Clean and check injector

4.8.7 Air is pulled through vent line

CAUSE	REMEDY
Pressure relief valve leaks	Replace valve
Valve stem does not close	Clean or replace valve stem
Spring in valve is defective	Replace spring

4.8.8 Rack does not move although positioner receives signals from control

CAUSE	REMEDY
Control knob pulled out (rack disengaged)	Push control knob in to engage rack
Mains supply failed	Check mains supply, switches and fuses
Rack is blocked	Check load (max. 135 N)
Limit switch in the positioner has switched	Check the limits, adjust if needed
Defective motor	Check the wire resistance
Defective gear (chattering sound)	Replace motor and gear
Defective circuit board	Replace circuit board

4.8.9 Rack does not move although control knob turns

CAUSE	REMEDY
Defective rack (wear)	Replace rack
Defective tooth wheel	Check teeth and clamping of wheel, replace motor gear if necessary

4.8.10 Rack moves in wrong direction

CAUSE	REMEDY
Motor wired wrongly	Check the terminal connections (swap 2 & 3 if appropriate)

4.8.11 Rack moves to the stop

CAUSE	REMEDY
Limit switch wrongly set or defective	Adjust positioner

4.8.12 Feedback signal will not align

CAUSE	REMEDY
Potentiometer wrongly set	Check potentiometer adjustment
Defective potentiometer (1kOhm ±10%)	Replace board (standard pot. only - for special pot. refer to Evoqua Water Technologies)
Defective wiring or terminals	Check terminals and wiring to the board
Toothed wheels or potentiometer shaft loose	Adjust pot. , clamp toothed wheels

4.8.13 Positioner moves without finding correct position

CAUSE	REMEDY
Positioner defective or loose	Move the rack by hand, check resistance of potentiometer, replace if necessary
Cable to control unit loose	Check cables
Defective capacitor	Replace circuit board

4.8.14 Positioner moves backwards and forwards

CAUSE	REMEDY
Positioner not correctly fixed to mounting	Check mounting plate or potentiometer loose

4.8.15 Positioner moves too slowly

CAUSE	REMEDY
Load too great, e.g. bad alignment load,	Check load, check positioner without check alignment

TYPE V10k GAS FEEDER

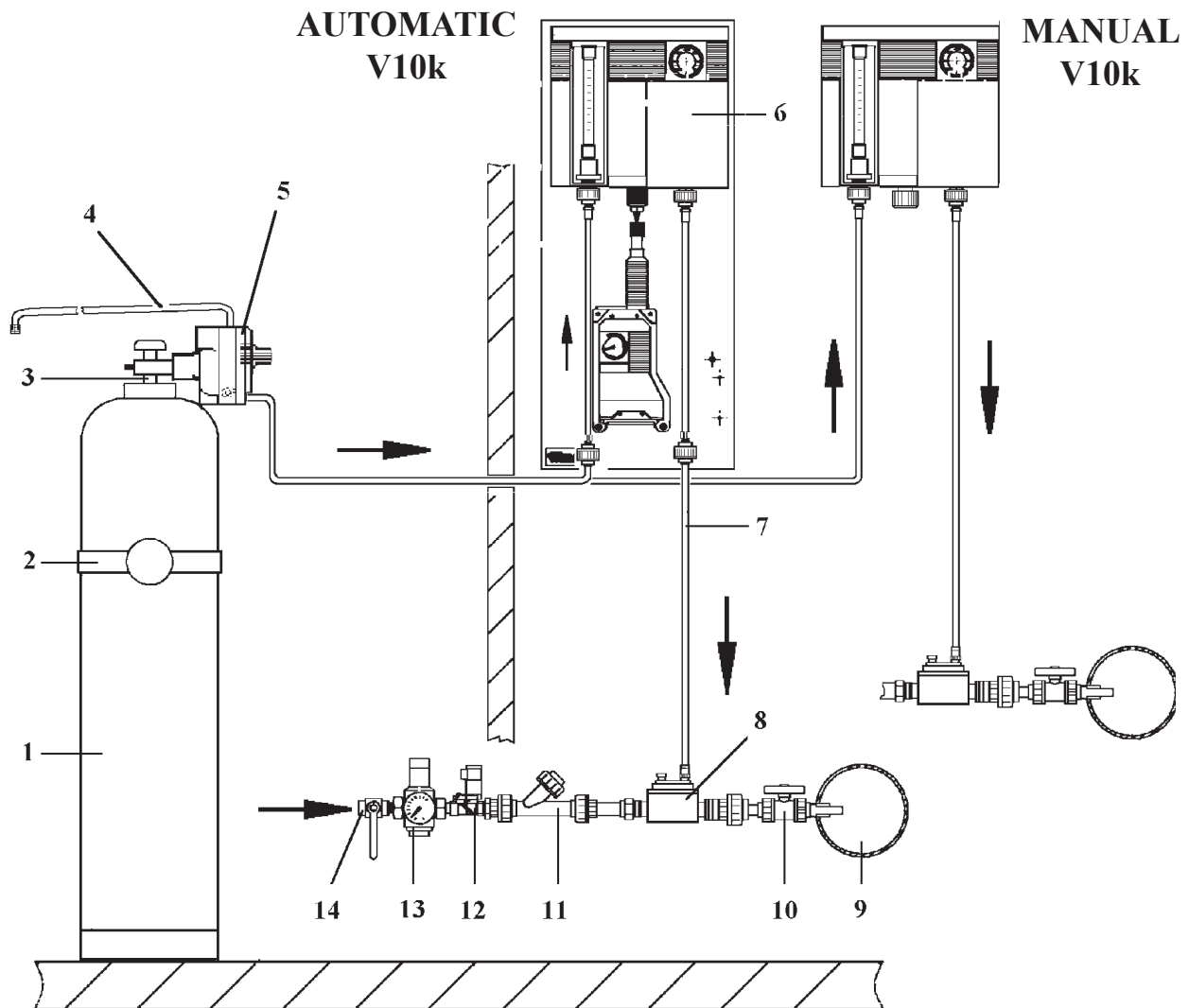

BZ 1276

TYPICAL V10k DOSING SYSTEM

- 1 Gas cylinder
- 2 Cylinder retainer
- 3 Main cylinder valve
- 4 Vent line
- 5 Vacuum demand valve
- 6 V10k Gas Feeder (see Fig.2)
- 7 Gas suction tube (see Fig.16)
- 8 Injector (see Figs.4 to 7)
- 9 Treatment main
- 10 Mains injection fitting
- 11 Non return valve
- 12 Solenoid valve
- 13 Pressure reducing valve
- 14 Isolating valve

FIG.1 TYPICAL V10k DOSING SYSTEM

TYPE V10k GAS FEEDER

KEY	PART No.		QTY	DESCRIPTION
	OLD	NEW		
1	U.26664	—	1	Differential vacuum valve (see Fig.3)
2	AAC8947	W3T168305	1	Manometer
	AAC8950	W3T166236	1	Nut
	P.97102	W2T503950	1	Hose connector
3	P.96974	W3T161473	2	Hose connector
	P.97105	W3T171125	2	PTFE Hose
4	PXF.96220	W2T505771	3	Oval head screw
	PXF.92139	W3T165423	3	Plain washer
5	PXB.95211	W2T504780	4	Anchor bolt
	P.100729	—	8	Plain washer
	PXD.100890	W2T507594	4	Dowel
	P.90659	—	4	Nut
	P.100388	—	4	Cap nut
6	-	—	1	SCU Module
	PXG.96220	W2T505721	4	Mounting screw
	AQC3797	W2T634677	4	Plain washer
7	P.44121	W2T161151	2	Gasket
8	Variable	—	1	Flowmeter (see Table at Fig2A)
9	P.95408	—	1	Name plate
10	PXA.97066	W3T172956	1	Panel
11	P.97018	W3T161478	1	V10K label
12	P.96960	W3T169050	1	Base
13	P.37880	W2T19769	1	Spring
14	-	-	-	See Fig.16
15	Variable	—	1	V-Notch (see Table 1)
	P.36861	W2T17711	1	Washer
	P.40153	W3T163275	1	Stud
16	P.37657B	W2T635542	1	Orifice
17	AAB1240	W3T169844	1	Extension chamber
	P.44045	W3T168909	1	'O' ring
18	AAB1246	W3T169846	1	Seal clamping screw
	PXA.26482	W2T11775	1	'O' ring
	P.34530B	W2T635517	1	Shaft seal
19	P.40139B	W2T635560	1	Plug stem
20	P.97027	W3T163456	1	Coupling
	P.97166	W3T167268	1	Hexagon nut
21	P.97026	W3T171121	1	Clamp.nut
	P.97028	W3T171122	1	Guiding washer
22	PXM.96220	—	4	Screw
	AQC3797	W2T634677	4	Plain washer
23	UXA.96285	W3T292482	1	Plug positioner, 230V
	UXD.96285	W3T292504	1	Plug positioner, 115V
24	UXD.95656	—	3	Cable gland (PG13.5)
	PXD.93767	—	3	Nut
	PXC.101189	—	2	Plug screw

IMPORTANT: When ordering spares quote machine serial number with full description and part number.

FIG.2 V10k GAS CONTROL UNIT

TYPE V10k GAS FEEDER

TABLE 1 V-NOTCH PLUGS								
Range (Cl ₂ /SO ₂)	V-notch plug (automatic)	New Part No.	V-notch plug (manual)	New Part No.	Seat	New Part No.	Spring (automatic only)	New Part No.
60 g/h	PXA.97057	—	P.88495	W2T635885	U.17641B	W3T292329	P.88701	W2T635907
200g/h	PXB.97057	W3T171215	P38071B	W2T14863	U17641B	W3T292329	—	—
400 g/h	PXC.97057	W3T171231	—	—	U.17641B	W3T292329	—	—
600 g/h	PXD.97057	W3T171242	—	—	U.17641B	W3T292329	—	—
1000 g/h	PXE.97057	W3T171251	—	—	U.17641B	W3T292329	—	—
1500 g/h	PXF.97057	W3T171254	—	—	U.17641B	W3T292329	—	—
2000 g/h	PXG.97057	W3T171260	P.38071B	W2T14863	U.17641B	W3T292329	—	—
3kg/h	PXH.97057	W3T171266	—	—	—	—	—	—
4 kg/h	PXI.97057	W3T171270	—	—	—	—	—	—
5 kg/h	PXJ.97057	W3T171272	—	—	—	—	—	—
6 kg/h	PXK.97057	W3T171275	—	—	—	—	—	—
8 kg/h	PXL.97057	W3T171277	—	—	—	—	—	—
10 kg/h	PXM.97057	W3T171279	P.48127	W3T159427	U.18075B (manual)	W2T636567	—	—
12 kg/h	PXN.97057	—	—	—	—	—	—	—
15 kg/h	PXO.97057	W3T171281	—	—	—	—	—	—

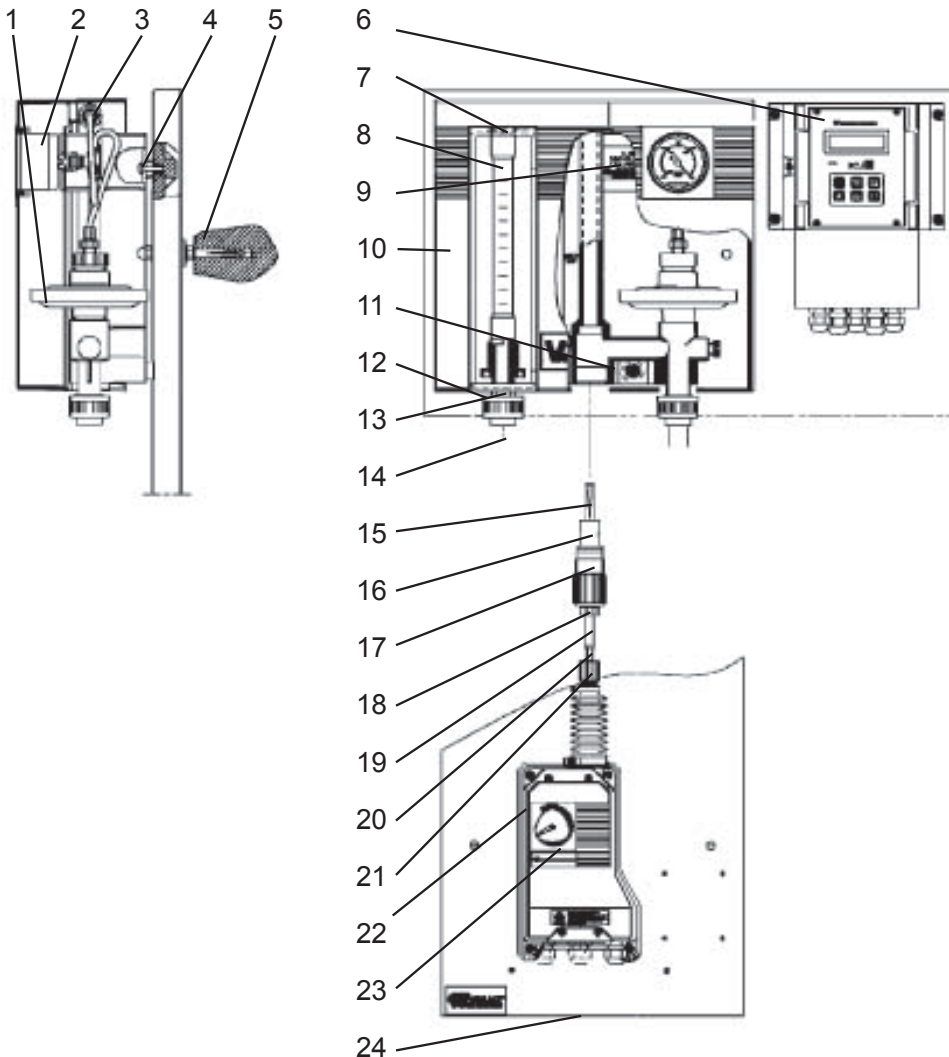

FIG.2 V10k GAS CONTROL UNIT

TYPE V10k GAS FEEDER

125mm (5") scale Flowmeters for Chlorine and Sulphur Dioxide		
Capacity	Part No. (old)	Part No. (new)
60 g/h	AAA.4105	W2T633089
200	AAA.4108	W2T633091
400	AAA.4111	W2T633092
600	AAA.4114	W2T633093
1000	AAA.4117	W2T633094
1.5 kg/h	AAA.4120	W2T633095
2	AAA.4123	W2T633096
3	AAA.4126	W2T633098
4	AAA.4129	W2T633099
5	AAA.4132	W2T633101
6	AAA.4135	W2T633102
8	AAA.4138	W2T633103
10	AAA.4141	W2T633104
12	AAB3600	W2T633708
15	AAB1401	W2T633576

125mm (5") scale Flowmeters for Carbon Dioxide		
Capacity	Part No. (old)	Part No. (new)
48 g/h	AAA.4183	-
160	AAA.4186	-
320	AAA.4189	-
480	AAA.4192	-
800	AAA.4195	-
1.2 kg/h	AAA.4198	-
1.6	AAA.4201	-
2.4	AAA.4204	-
3.2	AAA.4207	-
4	AAA.4210	-
4.8	AAA.4213	
6.4	AAA.4216	
8	AAA.4219	

125mm (5") scale Flowmeters for Ammonia					
Capacity	Part no. (old)	Part No. (new)	Capacity	Part no. (old)	Part No. (new)
1.5 - 30 g/h	AAA4144	W2T633105	0.75 - 1.5 kg/h	AAA.4165	W2T633111
5 - 100	AAA4147	-	0.1 - 2.0	AAA.4168	W2T633112
10 - 200	AAA4150	W2T633106	0.125 - 2.2	AAA.4171	-
15 - 300	AAA4153	W2T633107	0.15 - 3.0	AAA.4174	-
25 - 500	AAA4156	W2T633108	0.2 - 4.0	AAA.4177	-
37 - 740	AAA4159	W2T633109	0.25 - 5.0	AAA.4180	-
20 - 1000	AAA4162	W2T633109			

FIG.2A V10k FLOWMETERS

TYPE V10k GAS FEEDER

KEY	PART No.		QTY	DESCRIPTION
	OLD	NEW		
1	P.96974	W3T161473	2	Hose connector
2	P.97141	W3T169056	1	Plug
	P.37660	W2T635543	2	Gasket
3	P.38405	W2T635553	1	'O' ring
4	P.37656B	W2T635541	1	Stem holder
	P.38409	W2T635555	1	Stem
	P.37655	W3T161291	1	Pin
5	U.26664	W3T165515	1	Valve body assembly
6	P.48661B	W2T635577	1	Spring
	P.88701	W2T635907	1	Spring (60 g/hr capacity)
7	P.37660	W2T635543	2	Gasket
8	P.31295	W3T168893	1	Plug
9	U.17641B	W3T292329	1	Seat assembly (60 g/hr to 2kg/hr capacity)
	U.18075B	W2T636567	1	Seat assembly (3 to 10 kg/hr capacity)
	P.37661	W2T16446	1	Gasket
10	U.96294	W3T169313	1	Body (5")
	U.96295	W3T169314	1	Body (10")
11	AAA2502	W2T10203	2	Union nut
	AAA2553	W2T692923	1	Union end
	AAA3479	W2T10192	2	'O' ring

IMPORTANT: When ordering spare parts quote machine serial number with the full description and part number.

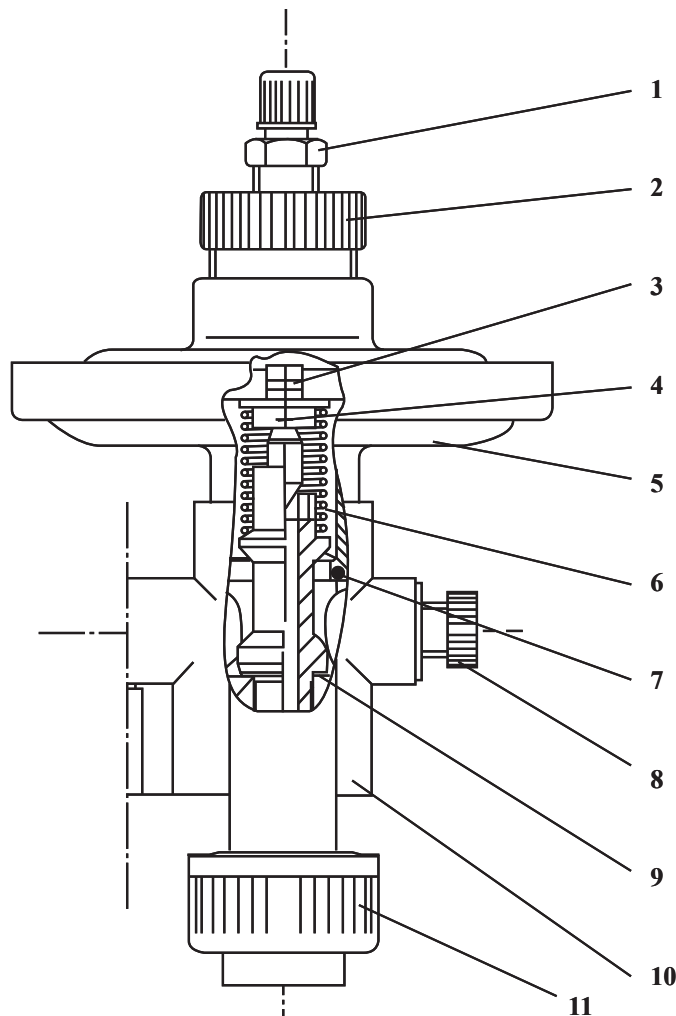

FIG.3 VACUUM DIFFERENTIAL VALVE

TYPE V10k GAS FEEDER

KEY	PART No.		QTY	DESCRIPTION
	OLD	NEW		
1	P.31295	W3T168893	1	Plug
2	P.37747	W3T161296	1	Plug
3	P.100363	—	1	Union nut
4	P.100355	—	1	Union end
	P.100457	W3T172724	1	O-ring
	P.100371	W3T172719	1	O-ring (NH3)
5	P.97050	W3T159666	1	Plug
6	P.97044	W3T172899	1	O-ring
	AAA5549	W3T160358	1	O-ring (NH3)
7	P.95279	W3T161434	1	O-ring
	PXC95968	W3T172997	1	O-ring (NH3)
8	P.97041	W3T161480	1	O-ring
	AAA5537	W3T160357	1	O-ring (NH3)
9	P.97040	W3T159661	1	Seat
10	P.48655	W2T376099	1	Spring
11	P.97032	W3T159656	1	Valve stem
12	P.97047	W3T172901	6	Screw
	P.97046	W3T172900	6	Washer
13	P.91485	W3T172882	1	O-ring
	P.100370	W3T172718	1	O-ring (NH3)
14	P.97048	W3T159664	1	Valve stem
15	P.31295	W3T168893	1	Plug
16	P.97342	W3T172921	1	O-ring
	P.97343	W2T507579	1	O-ring (NH3)
17	AAD2584	W3T170187	1	Valve seat
18	P.96971	W3T171119	1	Upper body
19	P.97062	W3T172902	1	Diaphragm
20	P.50524	W2T15514	1	O-ring
	AAA5582	W3T160359	1	O-ring (NH3)
21	P.91485	W3T172882	1	O-ring
	P.100370	W3T172718	1	O-ring (NH3)
22	ANM4147	W2T11157	1	Spring
23	P.97042	W3T171124	1	Lower body
24	P.97045	W3T159663	1	Clamping nut
25	P.85337	W2T635741	1	O-ring
26	P.85338	W2T635742	1	O-ring
27	P.38273B	—	1	Clamping nut
28	P.100448	W3T168867	1	O-ring
	AAA5555	W3T164205	1	O-ring (NH3)
29	P97049	W3T159665	1	Guide plug
30	P.83967	W2T635707	1	Inlet nipple

NOTE 1: For throat/tailway Part Nos. refer to Hydraulic Data which is found towards the rear of this manual.

IMPORTANT: When ordering spare parts quote machine serial number with the full description and part number.

FIG.4 U.96273 - 25mm INJECTOR

TYPE V10k GAS FEEDER

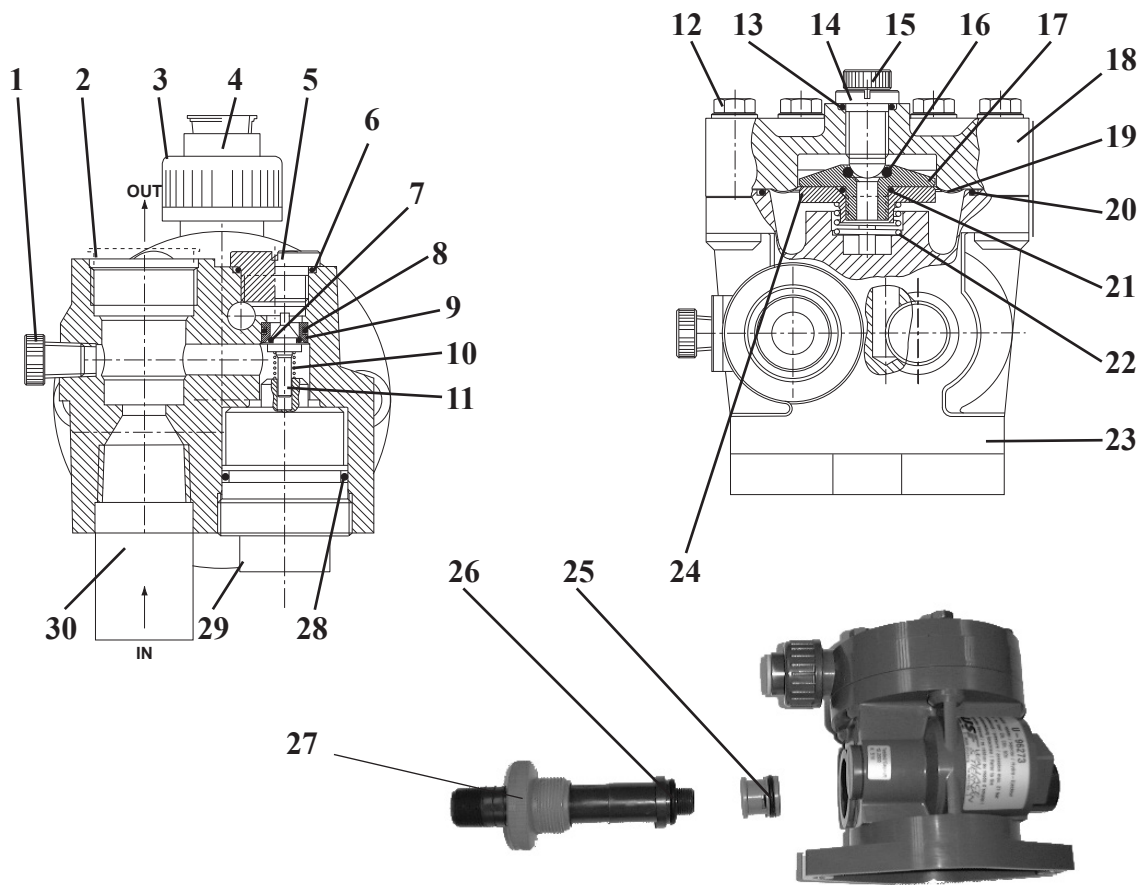

FIG.4 U.96273 - 25mm INJECTOR

TYPE V10k GAS FEEDER

KEY	PART No.	QTY	DESCRIPTION
	OLD	NEW	
1	P.97050	W3T159666	1 Plug
	P.97044	W3T172889	1 O-ring
	AAA5549	W3T160358	1 O-ring (NH3)
2	P.97032	W3T159656	1 Valve stem
	P.95279	W3T161434	1 O-ring
	PXC95968	W3T172997	1 O-ring (NH3)
3	P.97054	—	1 Guide bushing
4	P.97061	W3T159674	2 Diaphragm
	AAA5788	—	2 Diaphragm (NH3)
5	P.97053	—	1 Collet
6	P.97052	—	1 Spacer
7	P.100448	W3T168867	1 O-ring
	AAA5555	W3T164205	1 O-ring (NH3)
8	P.85337	W2T635741	1 O-ring
9	P.85338	W2T635742	1 O-ring
10	P.96970	—	1 Body
	P.95408	—	1 Name plate
11	P.97051	W3T159667	1 Clamping nut
12	P.97064	W3T172903	1 Spring
13	PXG.95967	W3T173063	1 Securing clip
14	P.97056	W3T159672	1 Diaphragm holder
15	P.97055	W3T159671	1 Clamping disc
16	P.83967	W2T635707	1 Barrel Nipple

NOTE 1:For throat/tailway Part Nos. refer to Hydraulic Data which is found towards the rear of this manual.

NOTE 2:The parts that form the top section of the injector are identical to the standard injector at Fig.4

IMPORTANT: When ordering spare parts quote machine serial number with the full description and part number.

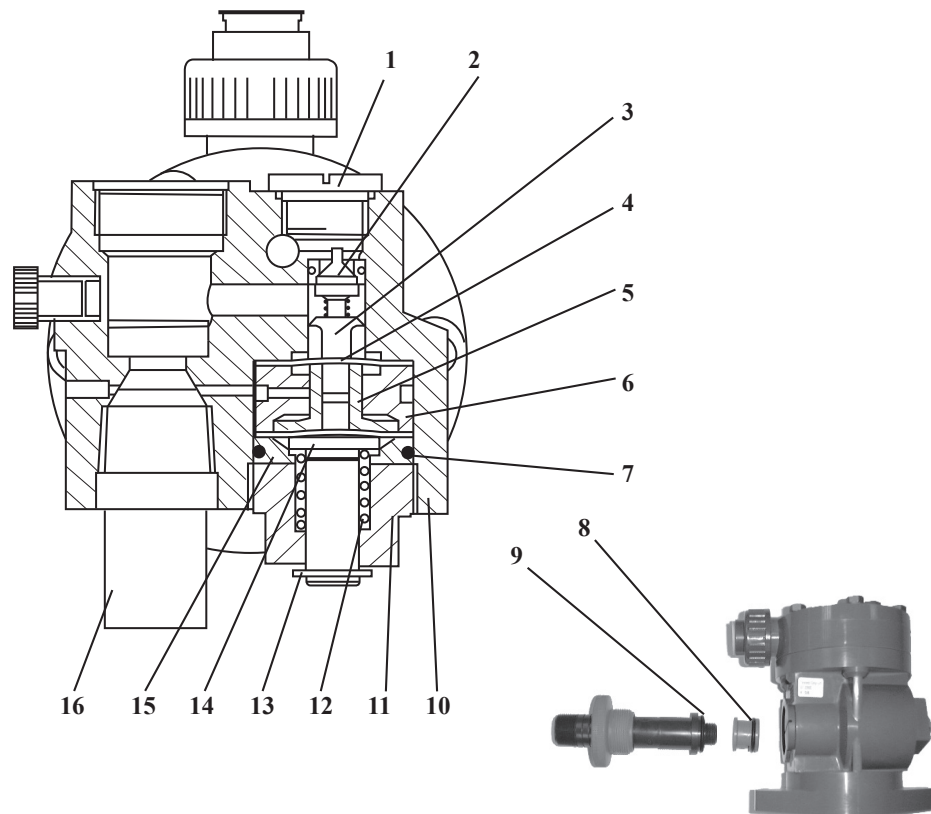

FIG.5 U.96274 - 25mm ANTI - SYPHON INJECTOR

TYPE V10k GAS FEEDER

KEY	PART No.		QTY	DESCRIPTION
	OLD	NEW		
1	P.34374	W2T12043	1	Plug
2	P.100363	—	1	Union nut
	P.100355	—	1	Union end
	P.100457	W3T172724	1	O-ring
	P100371	W3T172724	1	O-ring
3	P.97031	W3T159655	1	Inlet screw
4	P.100440	W3T168861	1	O-ring
	AAA5546	W3T164203	1	O-ring (NH3)
5	P.95279	W3T161434	1	O-ring
	PXC95968	W3T172997	1	O-ring (NH3)
6	P.48655	W2T376099	1	Spring
7	P.97032	W3T159656	1	Valve stem
8	P.31295	W3T168893	1	Plug
9	P.96973	W3T171120	1	Upper Body
10	P.97034	W3T159657	1	Valve stem
11	P.97342	W3T172921	1	O-ring
	P97343	W2T507579	1	O-ring
12	AAB.1489	—	1	Valve seat
13	PXA.26345	W2T17826	1	O-ring
	P100369	W3T168853	1	O-ring (NH3)
14	P.48976	W2T11964	1	Spring
15	APQ.3604	W2T634623	2	O-ring
16	P.95408	—	1	Name plate
17	P.96972	W3T159654	1	Lower Body
18	AAB.1495	—	1	Clamping nut
19	AAA.4325*	W3T171695	1	Upper diaphragm, Viton
	P.97063*	W3T161483	1	Lower diaphragm, ptfe
	AAA5785*	W3T164208	1	Diaphragm (NH3)
20	P.94729	W3T168988	1	O-ring
	AAA5543	W3T164202	1	O-ring (NH3)
21	P.91805	—	1	Union nut

* Ptfе diaphragm is placed nearest injector water.

NOTE 1:For throat/tailway Part Nos. refer to Hydraulic Data which is found towards the rear of this manual.

IMPORTANT: When ordering spares quote machine serial number with the full description and part number.

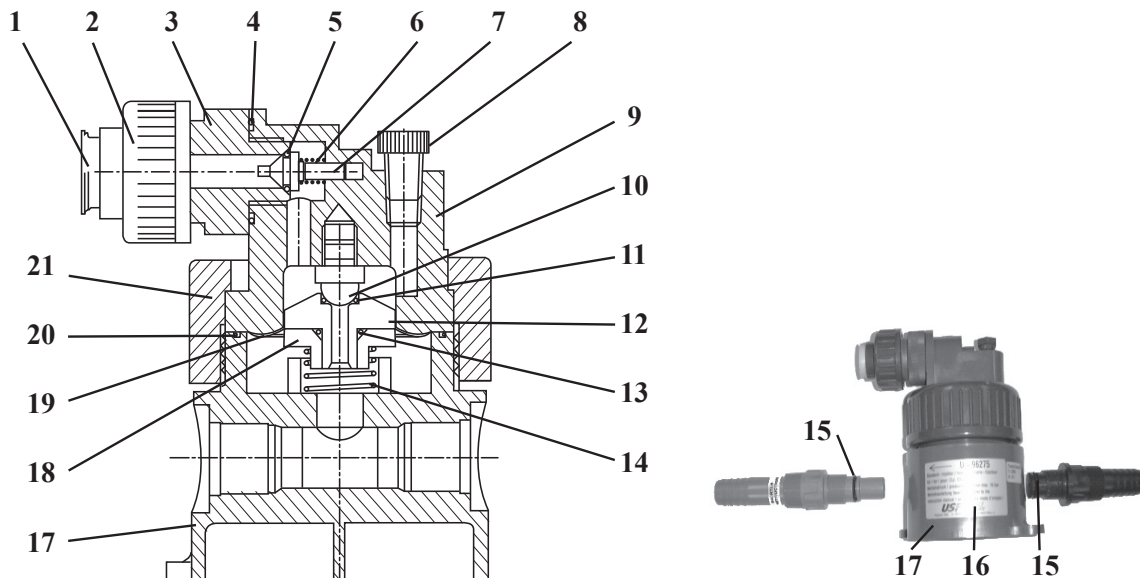

FIG.6 U.96275 - 19mm INJECTOR

TYPE V10k GAS FEEDER

KEY	PART No.	QTY	DESCRIPTION
	OLD	NEW	
1	P.97058	—	1 Body
	P.95408	—	1 Name plate
2	P.97035	—	2 Guide pin
3	P.97037	—	1 Disk
4	P.100440	W3T168861	2 Washer
5	P.91805	—	1 Union nut
6	P.94729	W3T168988	1 O-ring
7	P.97063	W3T161483	1 Diaphragm
8	APQ.3604	W2T634623	2 O-ring
9	P.97065	—	1 Spring
10	P.87812	W2T635808	1 O-ring
11	P.97033	—	1 Clamping nut
12	PXA.26345	W2T17826	1 O-ring
13	P.97036	—	1 Bottom cover
14	P.33847	—	2 Screw
15	PXA.25900	W2T407903	2 O-ring

NOTE 1: For throat/tailway Part Nos. refer to Hydraulic Data which is found towards the rear of this manual.

NOTE 2: The parts that form the top section of the injector are identical to the standard injector at Fig.6

IMPORTANT: When ordering spare parts quote machine serial number with the full description and part number.

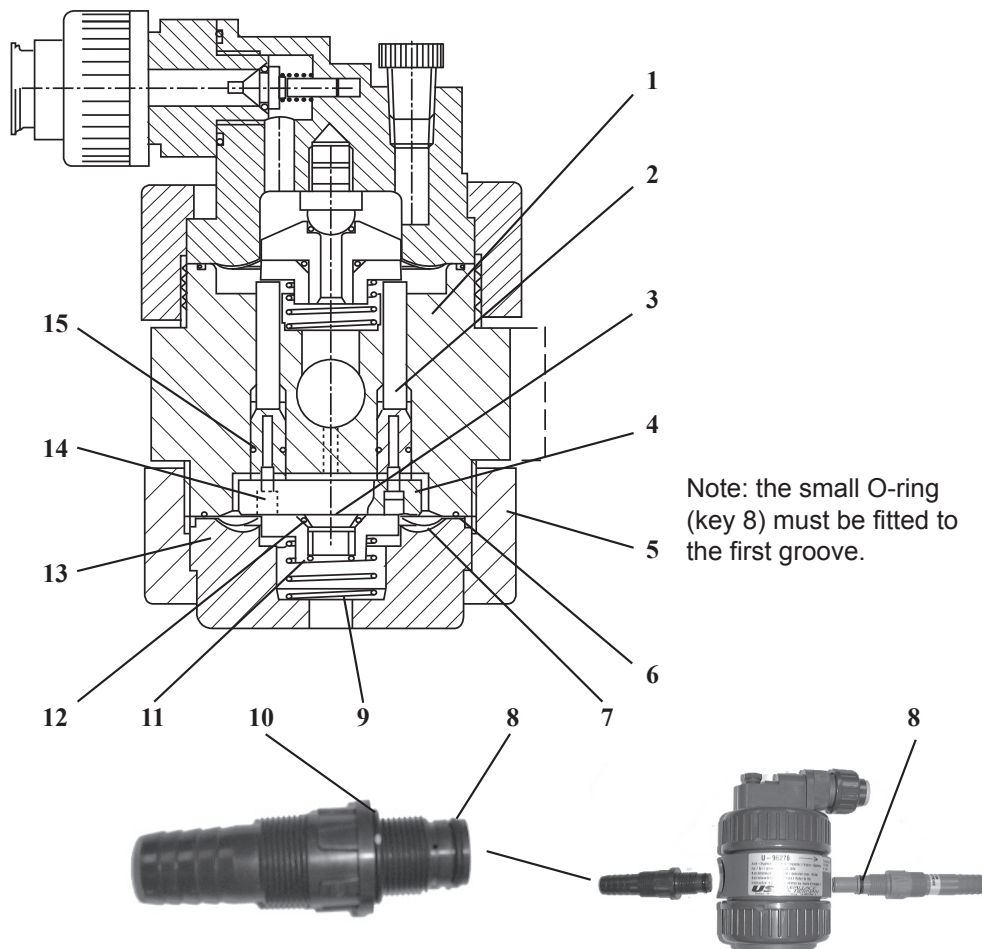

FIG.7 U.96276 - 19mm ANTI - SYPHON INJECTOR

THE INTERNAL VACUUM ALARM SWITCH IS NOT A USER SERVICABLE ITEM — THIS ILLUSTRATION IS PROVIDED TO SHOW THE BASIC OPERATION OF THE SWITCH

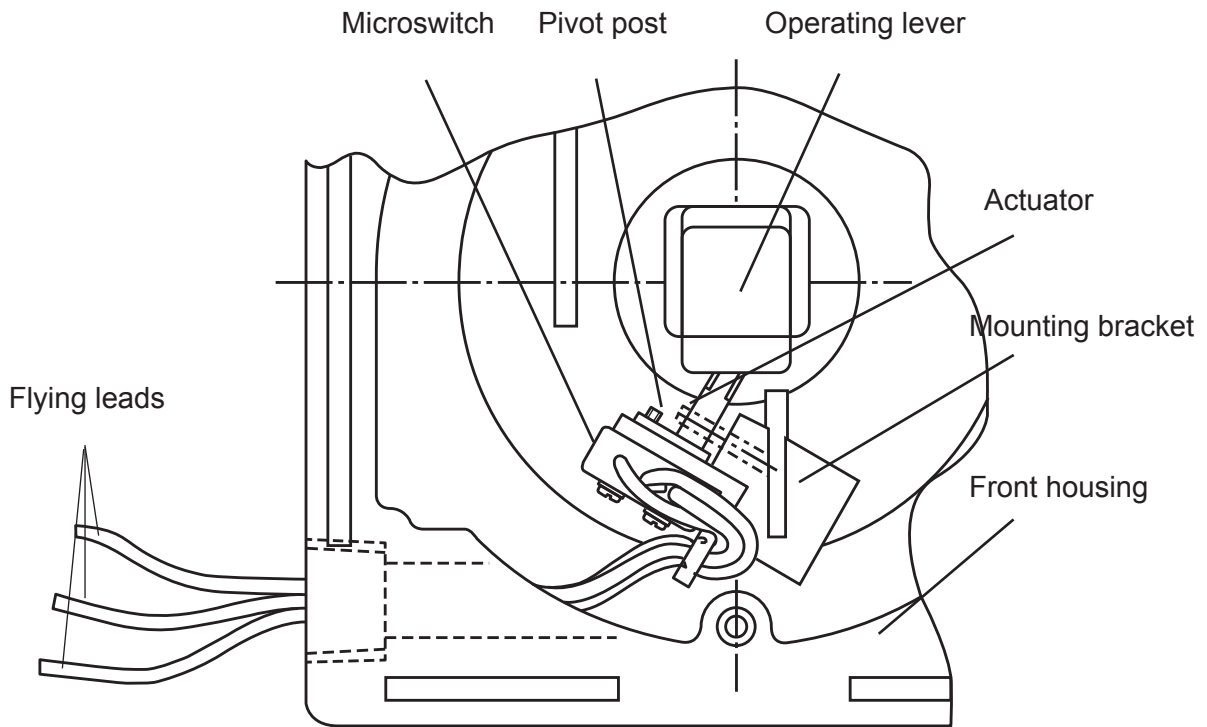

FIG.8 SINGLE FUNCTION VACUUM SWITCH

TYPE V10k GAS FEEDER

KEY	PART No.		QTY	DESCRIPTION
	OLD	NEW		
1	-		1	Differential vacuum valve, see Fig.3
2	PXA.96974	W3T169101	2	Adaptor for 6 mm od tubing
3	RP902.4426	W2T506980	-	Tube, 6 mm od x 4 mm id
4	-		1	Micro switch contact for 'GAS FAILURE' (Set at - 60" H2O)
5	ACG5135	W2T634457	1	Dual function vacuum switch
6	-		2	Micro switch contact for 'VACUUM FAILURE' (Set at - 8" H2O)

IMPORTANT: When ordering parts quote machine serial number with the full description and part number.

NOTE: On the standard vacuum switch the micro switches, rated at 5 amps, 240v/1ph/50hz supply, are wired so that with a healthy vacuum present the Vacuum Failure Contact is Normally Open and the Gas Failure Contact is Normally Closed.

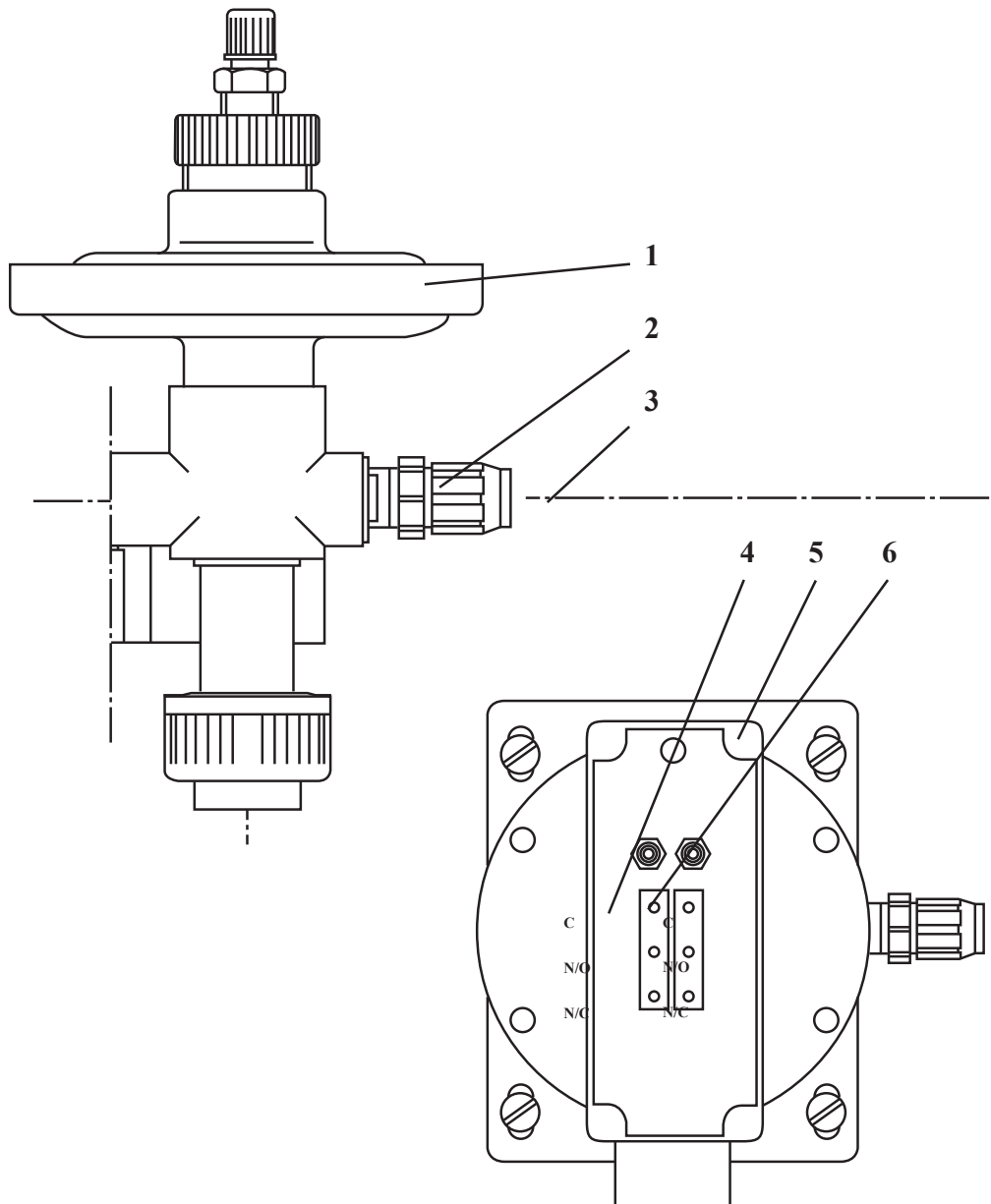
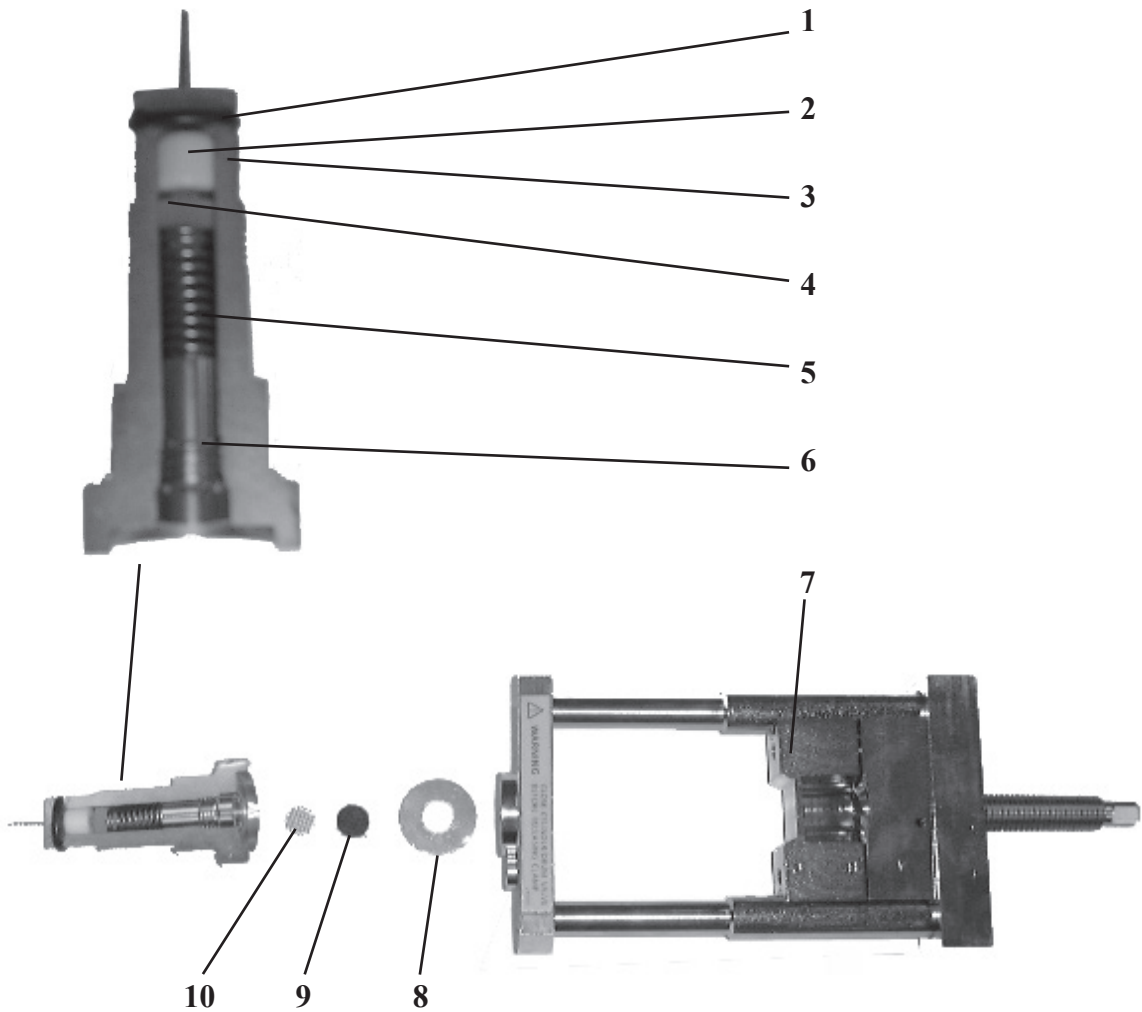

FIG.9 DUAL FUNCTION VACUUM SWITCH

TYPE V10k GAS FEEDER

KEY	PART No.	QTY	DESCRIPTION
	OLD	NEW	
-	AAA.6780	W2T633395	1 Universal yoke assy.
	AAB2058	W3T291627	1 Yoke Assembly (Ammonia Only)
1	AKG.5549	W2T367045	1 O ring
2	AAB.1736	W2T10156	1 Seat
3	AAB2291	W2T10012	1 Nipple
	AAA6225	W2T633350	1 Nipple (Ammonia only)
4	ANM.5366	W2T367090	1 Valve Stem
5	APQ.4110	W2T11229	1 Stem Spring
6	AAB2294	W2T10010	1 Retainer
	AAA6831	W2T633398	1 Retainer (Ammonia only)
7	AAA.6861	—	1 Universal follower head
8	P.60134	W2T12212	1 Lead washer
9	AAA.7109	W3T167914	1 Filter
10	AAA.7106	W3T167913	1 Screen
	AAA1328	—	1 Screen (Ammonia Only)

IMPORTANT: When ordering spares quote unit serial number with full description and part number.



NOTE: This assembly has been exploded for ease of parts identification

FIG.10 UNIVERSAL YOKE ASSEMBLY

TYPE V10k GAS FEEDER

KEY	PART No.	QTY	DESCRIPTION
	OLD	NEW	
-	AAA.6219	—	1 Chlorine Institute yoke assy.
1	P.19386	W2T11797	1 Yoke screw
2	P.44783	W2T11814	1 Yoke
3	P.11003	W2T635459	1 Pin
4	P.39369	—	1 Tag
5	P.25121	W2T11781	1 Clamp
6	P.16191	W2T635486	1 Lead gasket
7	AGK.5346	—	1 Nipple
	AKG.5549	—	1 O - ring
8	AAA.7106	W3T167913	1 Screen (1.27 x 1.27 monel wire mesh)
9	AIC.5355	W2T11202	1 Retainer
	AAA.6831	W2T633398	1 Retainer, Ammonia only
10	AAA.7109	W3T167914	1 Filter (1.57 thk PTFE)
	AAA.4699	W3T162239	1 Heater (optional) continuously variable from 115V to 230V
	AAA.3492	—	1 Backnut tool
	AAA.3486	—	1 Body
	AAA.3489	—	1 Handle

IMPORTANT: When ordering spares quote unit serial number with full description and part number.

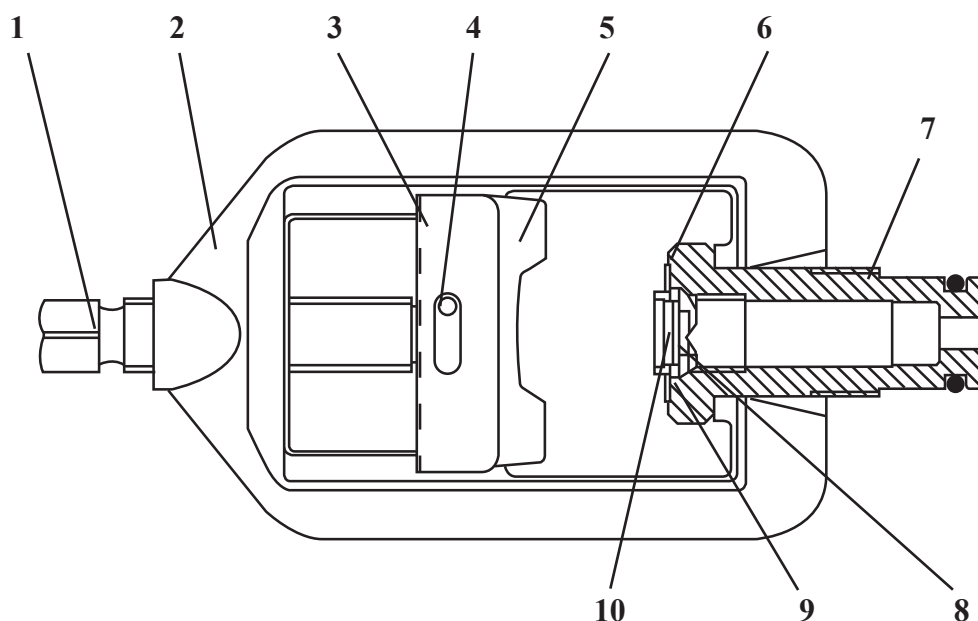

CAUTION: The mesh screen (8) must be inserted into the spring retainer (9) before the PTFE filter (10). If these items are placed in the wrong order the filter may be pulled into the valve by the vacuum.

FIG.11 CHLORINE INSTITUTE YOKE ASSEMBLY

TYPE V10k GAS FEEDER

KEY	PART No.	QTY	DESCRIPTION
	OLD		NEW
	U.1243B	1	Auxiliary cylinder valve, complete (chlorine)
	U.80412	1	Auxiliary cylinder valve, complete (sulphur dioxide)
	U.2065	1	Auxiliary cylinder valve, complete (ammonia)
1	P.84614	1	Control handle
2	P.86152	1	Packing nut
3	P.86153	1	Stem
4	P.614B	1	Packing
5	P.2991B	1	Body
	P.6733B	1	Body (ammonia)
6	PC.11	1	Union nut
	PC.6749	1	Union nut (ammonia)
	P.2519	2	Gasket
7	PC.230	1	Union nipple
	PC.6714	1	Union nipple (ammonia)
8	PC.128	1	Nut (chlorine)
	P.81668	1	Nut (sulphur dioxide)
	P.86510	1	Nut (ammonia)
9	PC.120	1	Gland (chlorine)
	P.81666	1	Gland (sulphur dioxide)
	P.6734B	1	Gland (ammonia)
10	P.2985	1	Collar
	P.6732	1	Collar (ammonia)

IMPORTANT: When ordering spare parts quote machine serial number together with full description and part number.

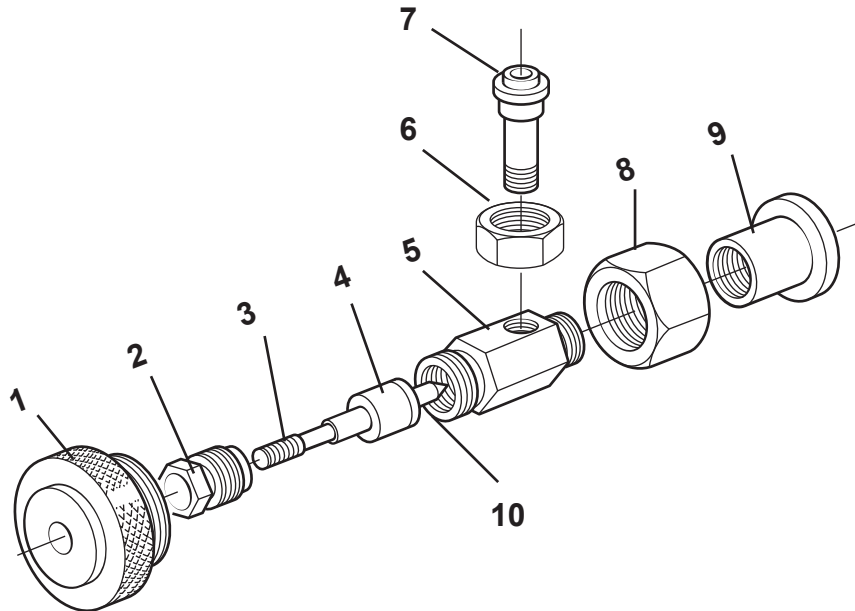

FIG.12 AUXILARY CYLINDER VALVE

TYPE V10k GAS FEEDER

KEY	PART No.		QTY	DESCRIPTION
	OLD	NEW		
	U.80440	W3T292357	1	Auxiliary drum valve, complete (chlorine)
	U.80084	W3T292353	1	Auxiliary drum valve, complete (sulphur dioxide)
1	P.5822	W3T292185	1	Wrench
2	P.5730	W2T19495	1	Packing gland
3	P.30428B	W2T635506	1	Packing
4	PR.83842	—	1	Union nut (chlorine)
	P.81668	W2T635677	1	Union nut (sulphur dioxide)
5	P.80893	W2T635642	1	Adaptor (chlorine)
	P.80337	W2T635627	1	Adaptor (sulphur dioxide)
6	P.80899	W3T292190	1	Body
7	P.5728	W2T635599	1	Stem
8	P.5731	W2T19496	1	Packing ring
9	P.5729	—	1	Packing nut

IMPORTANT: When ordering spare parts quote machine serial number together with full description and part number.

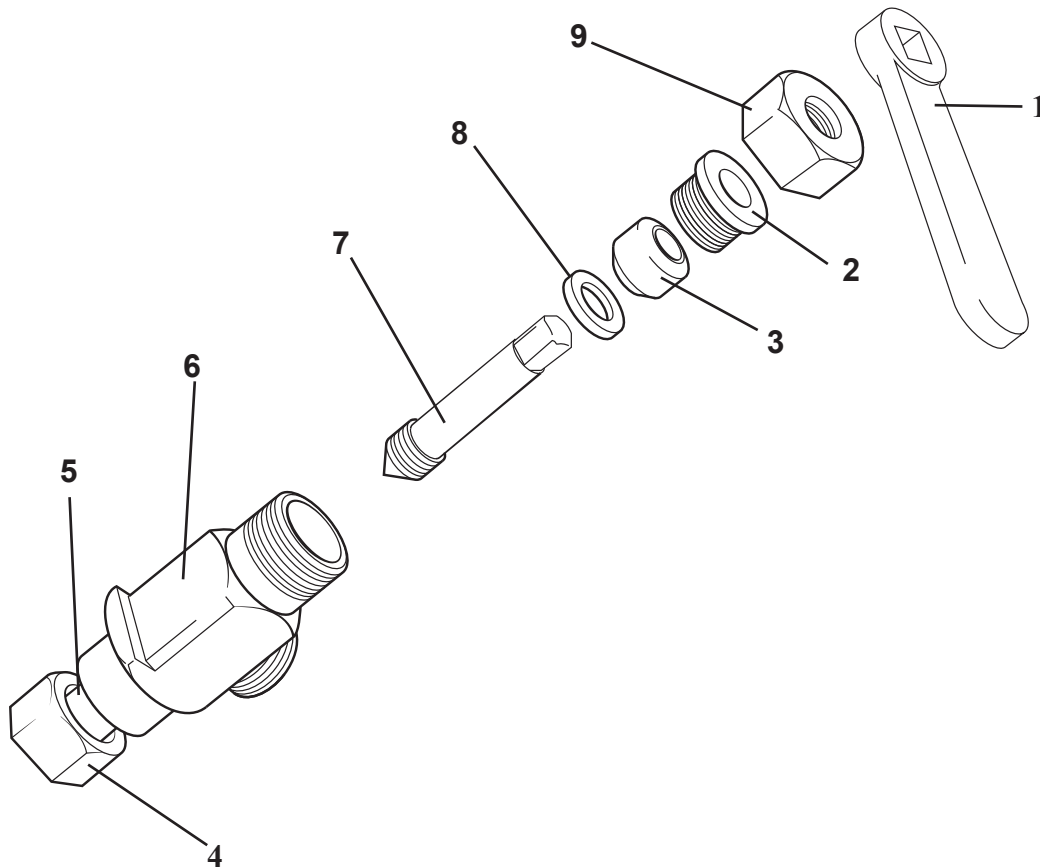

FIG.13 AUXILIARY DRUM VALVE

TYPE V10k GAS FEEDER

KEY	PART No.		QTY	DESCRIPTION
	OLD	NEW		
-	U.82363	W3T292365	1	Large header valve (Cl ₂ /SO ₂)
-	U.80728	W3T292359	1	Large header valve (Ammonia)
1	P.5822	W3T292185	1	Wrench
2	P.5730	W2T19495	1	Packing gland (Cl ₂ /SO ₂)
	P.81400	W2T635659	1	Packing gland (Ammonia)
3	P.30428B	W2T635506	1	Packing
4	P.80794	W3T292189	1	Body (Cl ₂ /SO ₂)
	P.81398	W2T635657	1	Body (Ammonia)
5	P.5728	W2T635599	1	Stem (Cl ₂ /SO ₂)
	P.81399	W2T635658	1	Stem (Ammonia)
6	P.5731	W2T19496	1	Packing ring (Cl ₂ /SO ₂)
	P.81401	W2T635660	1	Packing ring (Ammonia)
7	P.5729	—	1	Packing nut (Cl ₂ /SO ₂)
	P.81402	W2T635661	1	Packing nut (Ammonia)

IMPORTANT: When ordering spare parts quote machine serial number together with full description and part number.

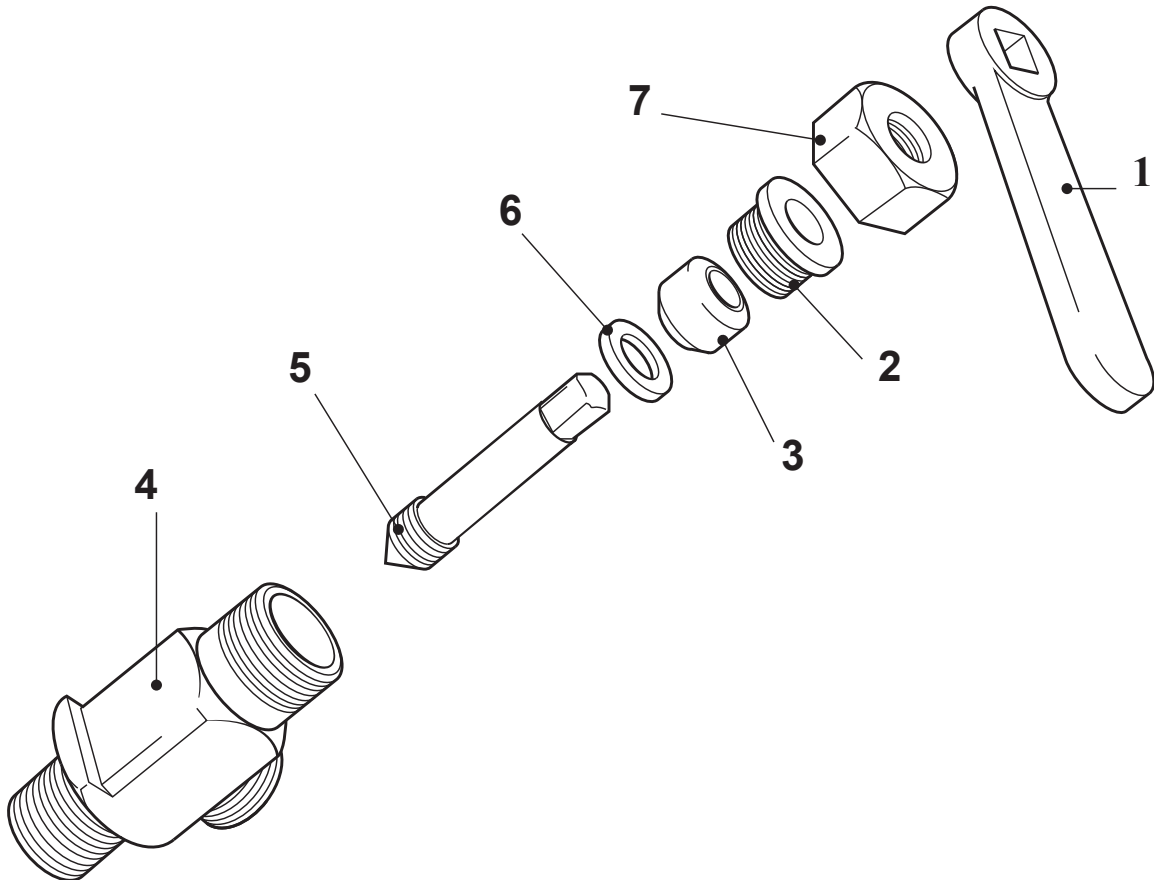
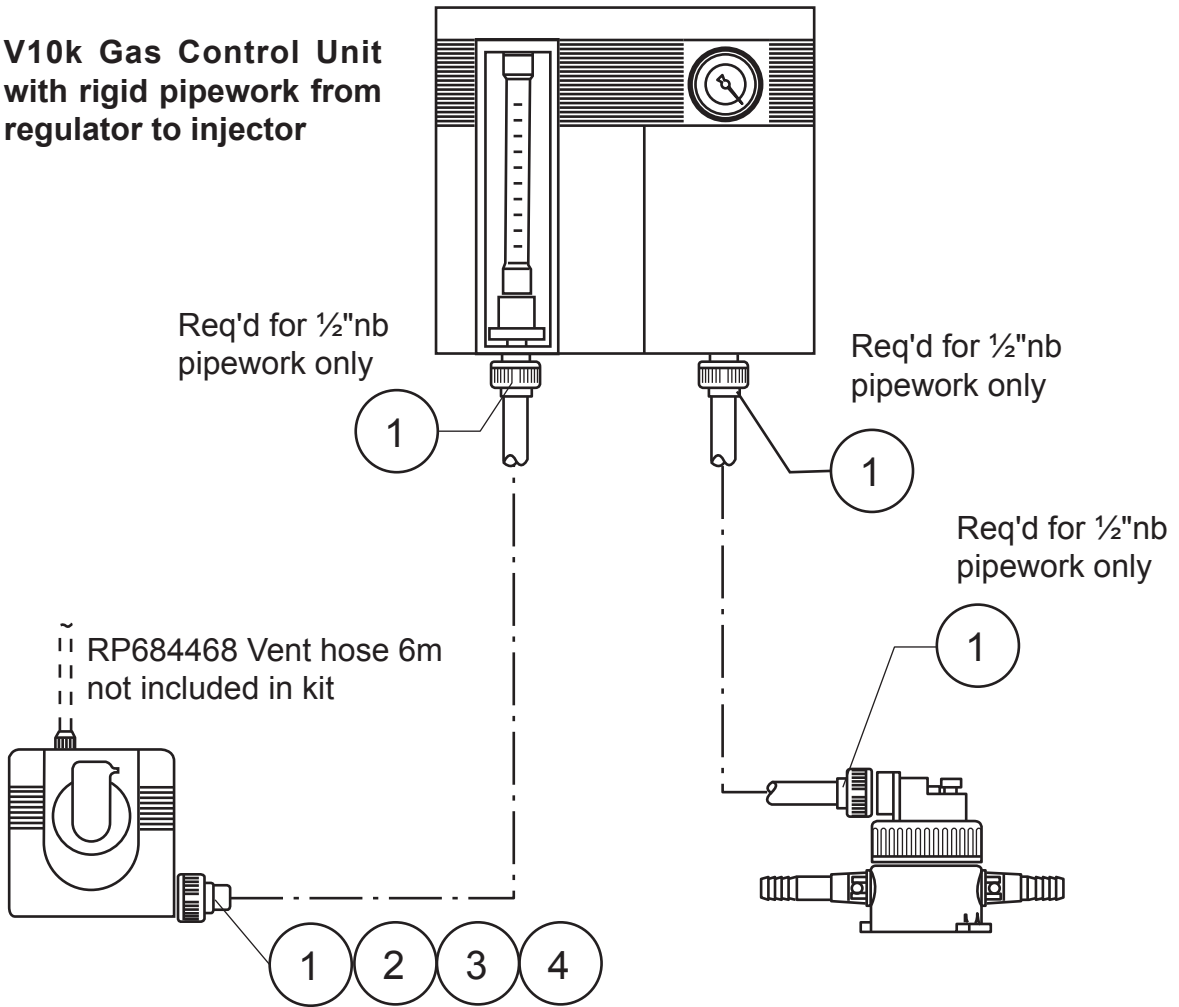

FIG.14 LARGE HEADER VALVE

TYPE V10k GAS FEEDER

V10k Gas Control Unit with rigid pipework from regulator to injector



Parts kit AAA7497 — Arrangement B				
No	Part No. (old)	Part No. (new)	Description	QTY
1	AAA2523	W2T10205	Union end 1/2" plain	4
2	AAA3479	W2T10192	O-ring	1
3	AAA2502	W2T10203	Union nut	1
4	AAA2925	W3T162234	Connector	1

Parts kit AAA7500 — Arrangement C				
No	Part No. (old)	Part No. (new)	Description	QTY
1	AAA2553	W2T632923	Union end 20mm plain	1
2	AAA3479	W2T10192	O-ring	1
3	AAA2502	W2T10203	Union nut	1
4	AAA2925	W3T162234	Connector	1

FIG.15 VACUUM LINE CONNECTIONS (Drg.XAC1027 (Sht 1 of 3))

TYPE V10k GAS FEEDER

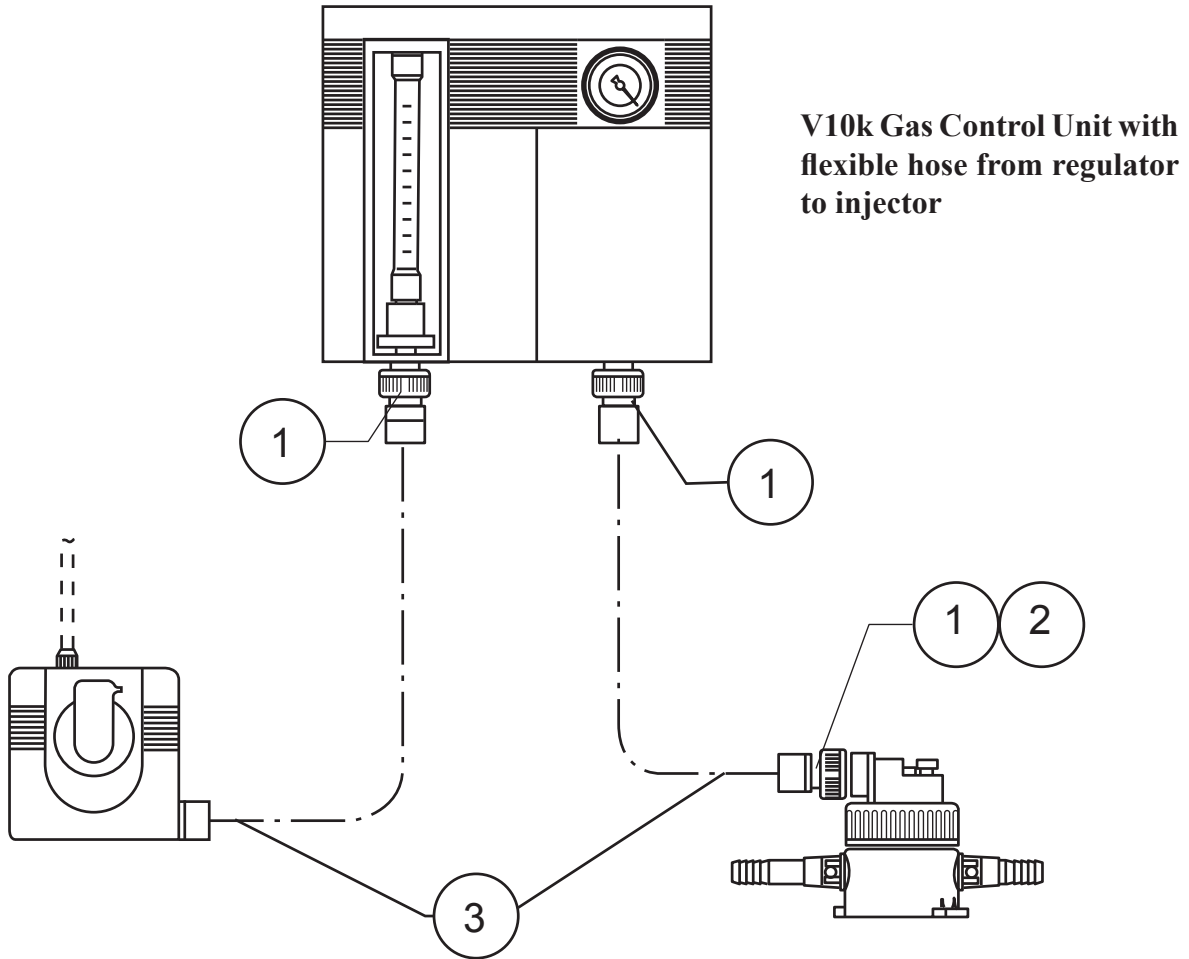

Parts kit AAA7494 — Arrangement D				
No	Part No. (old)	Part No. (new)	Description	QTY
1	AAA3267	W2T633002	Union end 1/2" NPT	4
2	U27486	W3T99057	Connector 1/2" NPT	1
3	RP684484	W2T636355	Polyethylene Hose 1/2" OD 3/8" ID	1

FIG.15 VACUUM LINE CONNECTIONS (Drg.XAC1027 Sht. 2 of 3)

TYPE V10k GAS FEEDER

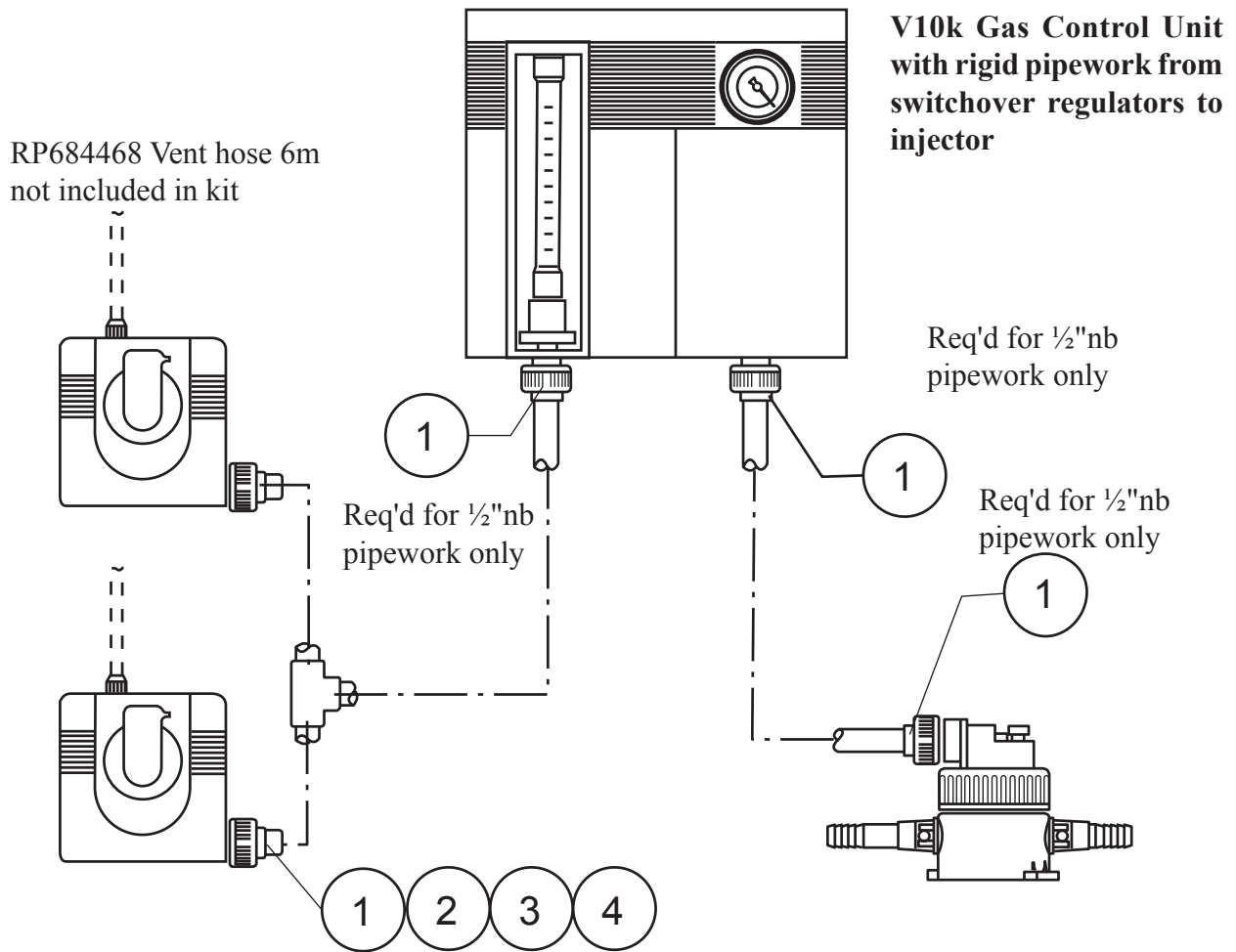

Parts kit AAA7503 — Arrangement E

No	Part No. (old)	Part No. (new)	Description	QTY
1	AAA2523	W2T10205	Union end 1/2" plain	4
2	AAA3479	W2T10192	O-ring	1
3	AAA2502	W2T10203	Union nut	1
4	AAA2925	W3T162234	Connector	1

Parts kit AAA7506 — Arrangement F

No	Part No. (old)	Part No. (new)	Description	QTY
1	AAA2553	W2T632923	Union end 20mm plain	1
2	AAA3479	W2T10192	O-ring	1
3	AAA2502	W2T10203	Union nut	1
4	AAA2925	W3T162234	Connector	1

FIG.15 VACUUM LINE CONNECTIONS (Drg.XAC1027 Sht 3 of 3)

TYPE V10k GAS FEEDER

KEY	PART No.	NEW	QTY	DESCRIPTION	
	OLD	NEW			
1	U.81903	—	1	Junction box and conduit	
2	U.82518	W2T636607	1	Gas gauge, 0-10 bar, Cl ₂	
	U.82519	W2T636608	1	Gas gauge, 0-4 bar, SO ₂	
	U.82520	W2T636609	1	Gas gauge, 0-16 bar, NH ₃	
3	U.80535	W3T292358	1	Bracket	
	P.81097	—	2	Screw, 3/4" lg	
4	U.81954	W2T636599	1	Tube assy, Cl ₂ /SO ₂	
	P2519	W2T17102	1	Gasket,	
	U.2066	W2T636570	1	Tube assy, NH ₃	
	32693E	—	1	Adaptor, NH ₃	
	P.2519	W2T17102	1	Gasket	
5	See Fig.8	—	1	Vacuum demand valve	
6	U.82363	W3T292365	1	Large header valve, Cl ₂ /SO ₂	
	U.80728	W3T292359	1	Large header valve, NH ₃	
7	P.89321	W2T635944	2	Tee, Rc 3/4	
	P.81255	W3T292193	1	Taper nipple, R3/4	
8	P.83482	W2T635699	1	Flange	
	P.89350	W2T635951	1	Plug nipple, R3/4	
	P.89325	W2T635948	1	Reducing bush, R3/4xRc3/4	
9	P.89326	W2T635949	1	Reducing bush, R1/4x 1/8 NPT	
	PN.230	W2T636093	1	Union nipple, Cl ₂ /SO ₂	
	PN.11	W2T636090	1	Union nut, Cl ₂ /SO ₂	
	PN.6749	—	1	Union nipple, NH ₃	
	PN.6714	—	1	Union nut, NH ₃	
	10	P.89320	W2T635943	1	Elbow, Rc3/4
	11	See Key 5	—	1	Large header valve
12	P.83482	W2T635699	1	Flange	
	P.89350	W2T635951	1	Plug nipple, R3/4	
	P.89321	W2T635944	1	Tee, Rc 3/4	
	P.81255	W3T292193	1	Taper nipple, R3/4	
	13	Keys 9 - 11	—	-	Wall unit
14	P.89322	W2T635945	1	Cross, Rc3/4	
15	U.80413	W3T292356	1	Small header valve, Cl ₂ /SO ₂	
	U.80916	W3T292362	1	Small header valve, NH ₃	

IMPORTANT: When ordering spares quote unit serial number with full description and part number.

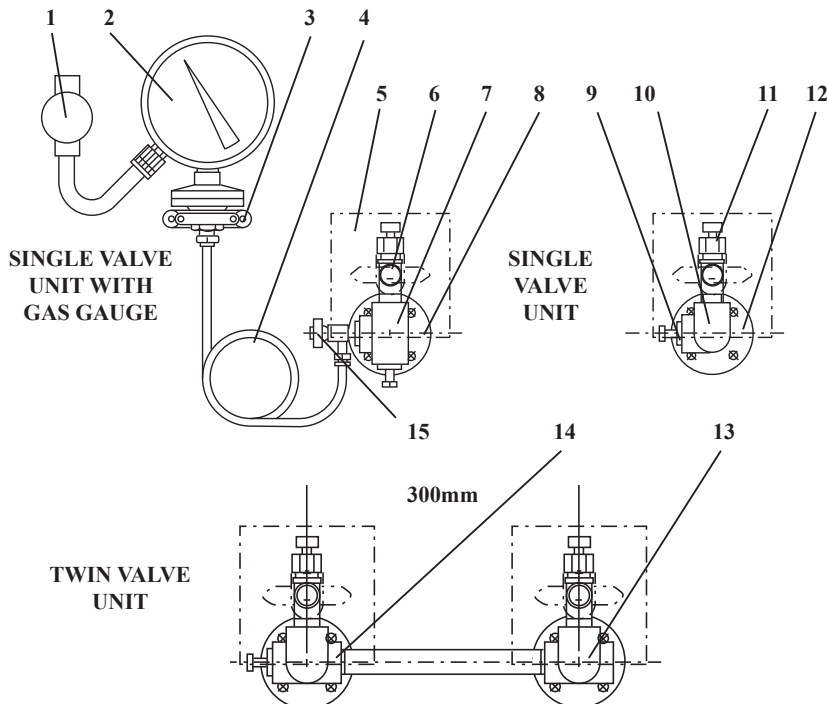

FIG.16A HEADER MANIFOLDS — MULTI-DEMAND VALVE

TYPE V10k GAS FEEDER

KEY	PART No.	QTY	DESCRIPTION
	OLD		NEW
1	U.80413	1	Small header valve, Cl ₂ /SO ₂ . See Detail 'A'
	U.80916	1	Small header valve, NH ₃
2	P.89325	1	Reducing bush, R ³ / ₄ xRc ³ / ₄
3	P.83482	1	Wall mounting flange
	P.89350	1	Plug nipple, R ³ / ₄
4	P.89321	1	Tee, Rc ³ / ₄
5	AAA.5349	1	Barrel nipple, 250 lg
6	Keys 1,2 & 4	-	Cylinder connection point
7	AAA.6027	1	Barrel nipple, 100 lg
8	See Fig.8	1	Vacuum demand valve
9	U.82363	1	Large header valve Cl ₂ /SO ₂ see Fig.15
	U.80728	1	Large header valve Ammonia, see Fig.15
10	P.89320	1	Elbow, Rc ³ / ₄
11	P.83482	1	Wall mounting flange
	P.89350	1	Plug nipple, R ³ / ₄
	P.89321	1	Tee, Rc ³ / ₄
	P.81255	1	Close nipple, R ³ / ₄
11	P.83482	1	Wall mounting flange
	P.89350	1	Plug nipple, R ³ / ₄
	P.89321	1	Tee, Rc ³ / ₄
	P.81255	1	Close nipple, R ³ / ₄
12	P.2985	1	Collar, Cl ₂ /SO ₂
	P.6732	1	Collar, Ammonia
13	P.84614	1	Handle, Cl ₂ /SO ₂
	P.87009	1	Handle, Ammonia
14	P.86152	1	Packing nut
15	P.86513	1	Stem
16	P.614B	1	Packing
17	P.2991B	1	Body, Cl ₂ /SO ₂
	P.6733B	1	Body, Ammonia
18	PN.11	1	Union nut, Cl ₂ /SO ₂
	PN.6749	1	Union nut, Ammonia
19	PN.230	1	Union nipple, Cl ₂ /SO ₂
	PN.6714	1	Union nipple, Ammonia

IMPORTANT: When ordering spares quote unit serial number with full description and part number.

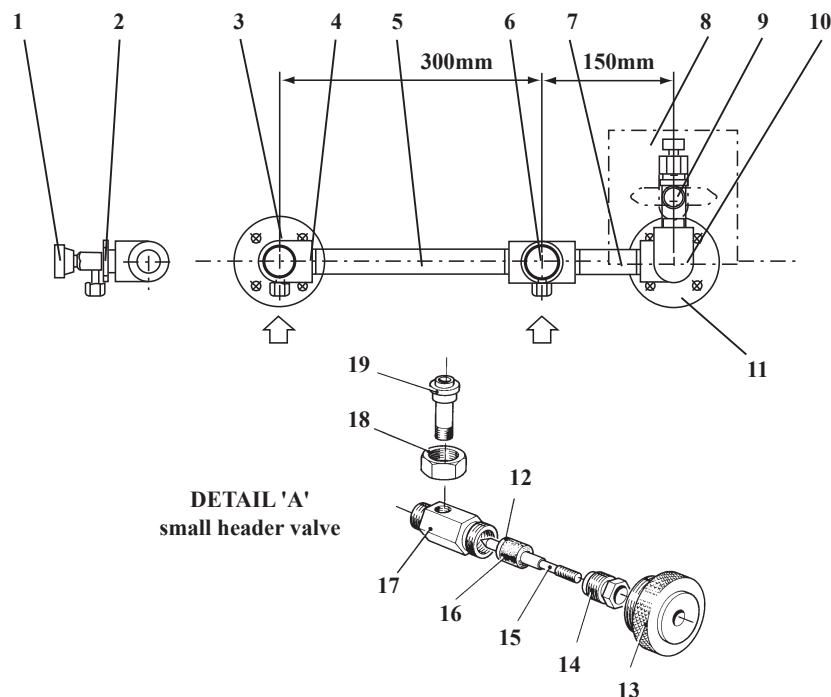

FIG.16B HEADER MANIFOLDS — MULTI-CYLINDER

TYPE V10k GAS FEEDER

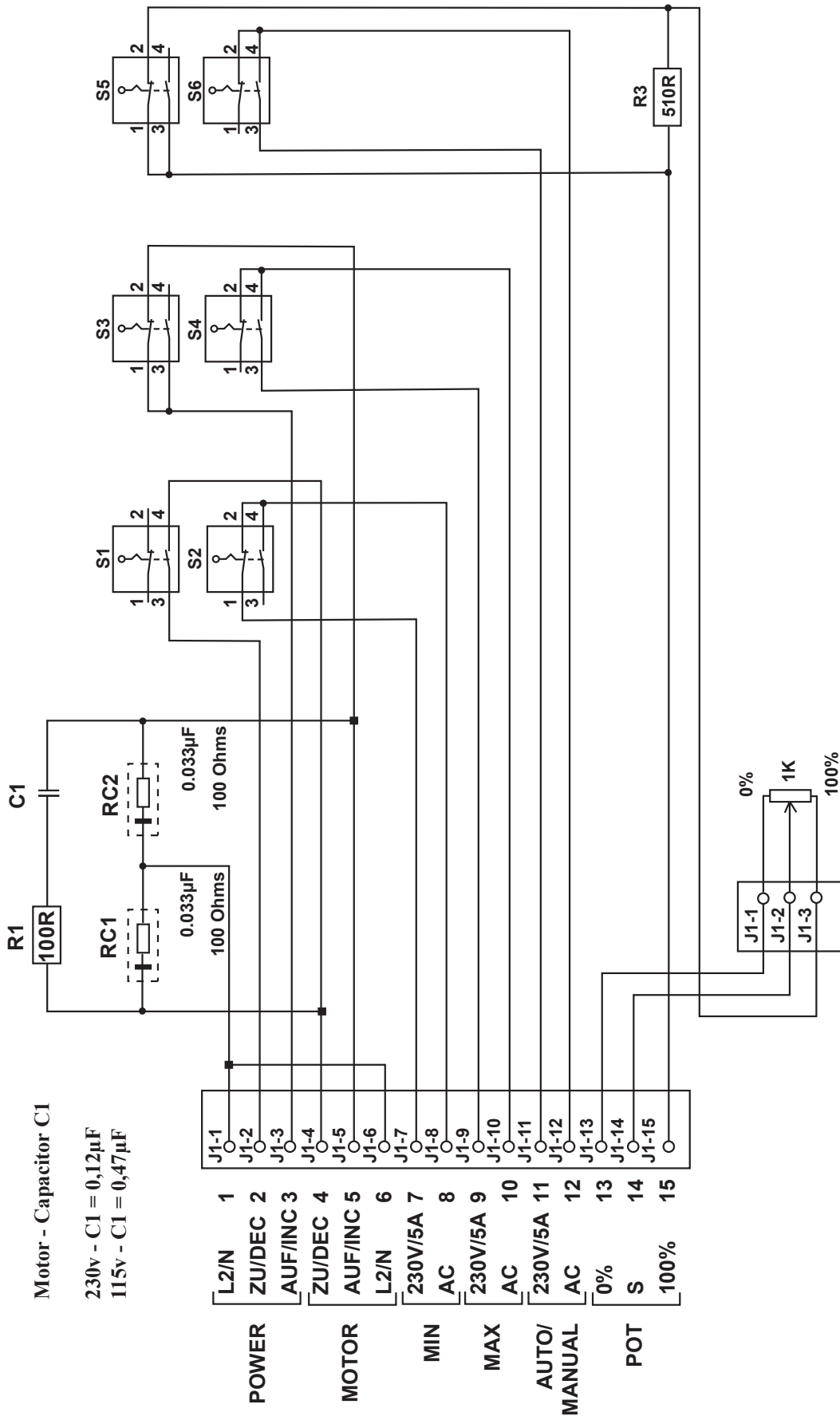

FIG.17 EXTERNAL CONNECTION DIAGRAM (Drg.30-E-7662)

Injector Operating Requirements

The following pages have been included to assist in the determination of the water pressure and flow required to operate the gas feeders under various conditions. The hydraulic data for the ¾" injector is applicable to systems with a capacity of up to 5 kg/h, whilst the hydraulic data for the 1" injector applies to systems with a capacity of up to 15 kg/h.

Before commencing work with these charts, it is necessary to have some idea of the hydraulic conditions on site. Once the 'back pressure' (essentially the mains pressure at the point of chlorine injection plus an allowance for friction losses) is known, the selection can be made.

As an example, assume a gas feeder, with a chlorine capacity of 4 kg/h, using a ¾" (19 mm) injector, to operate against a mains pressure of 1 bar. Search for the data block associated with the ¾" injector for the next highest back pressure above the actual. In our example this will be 1.4 bar. Within that block follow the line across relevant to the 4 kg/h capacity.

You will see that the column headed '140' is 7.1/G, in the column headed '193' is 6.1/J and in the column headed '242' is 5.4/J. This means that fitting the injector with a 140G venturi (throat and tailway) combination will require 7.1 bar operating pressure, 193J combination will require 6.1 bar and 242J will require 5.4 bar. These are minimum pressure requirements at the injector inlet for satisfactory operation against the total back pressure calculated at the injector outlet.

Now refer to the graph at the end to establish the minimum operating flow for each combination. Read vertically up from the operating pressure figure for a given venturi (throat and tailway) combination to the point of intersection with the appropriate diagonal line. From the point of intersection, read horizontally to the left to establish the water flow. For example, using the 140G combination, requiring 7.1 bar operating pressure, the appropriate minimum water flow is approximately 1.4 m³/h. You will note that the venturi combinations requiring a smaller differential pressure (in this example 193J and 242J) have a higher flow requirement.

NOTE: As with the pressure requirements, these are the minimum flow requirements.

Should it be necessary to select a booster pump to operate the injector, it is strongly recommended that an allowance be made for the friction loss between the booster pump outlet and the injector inlet, plus the booster pump suction pipework should be carefully considered to ensure that the booster pump suction pressure is achievable under flow conditions.

HYDRAULIC DATA FOR 3/4"-INJECTOR

Part No.

Standard	Throat	No.	Tailpiece	Code
	Anti-syphon			
PXE48961	PXE49042	99	PXD-48962	D
PXG48961	PXG49042	140	PXE48962	E
PXJ48961	PXJ49042	193	PXF48962	F
PXK48961	PXK49042	242	PXG48962	G
			PXH48962	H
			PXJ48962	J

Chlorine	Back Pressure	Injector Throat and Tail															
		g/h	bar	99	*			140	*			193	*	242	*		
200	0	1.6	D			1.0	F										
400	"	2.4	D			1.2	F			0.9	G						
600	"	3.3	D			1.4	F			1.0	J						
1000	"	3.6	D			1.6	F			1.3	J						
1500	"	4.5	D			2.5	F			1.8	J	1.4	J				
2000	"	5.3	F			3.4	F			2.4	J	1.9	J				
3000	"					4.2	G			4.7	J	2.6	J				
4000	"					5.8	G					3.9	J				

Chlorine	Back Pressure	Injector Throat and Tail															
		g/h	bar	99	*			140	*			193	*	242	*		
200	0.2	1.7	D			1.2	F										
400	"	2.6	D			1.4	F										
600	"	3.3	D			1.6	F										
1000	"	3.8	D			1.8	F			1.5	J						
1500	"	4.8	D			2.7	F			2.0	J	1.6	J				
2000	"	7.1	E			3.6	G			2.5	J	2.1	J				
3000	"					4.1	G			3.5	J	2.9	J				
4000	"					5.8	G					4.1	J				
5000	"					7.1	G					6.5	J				

TYPE V10k GAS FEEDER

Chlorine g/h	Back Pressure bar	Injector Throat and Tail													
		99	*			140	*			193	*	242	*		
200	0.4	2.0	D			1.3	F								
400	"	3.1	D			1.6	F								
600	"	3.6	D			1.8	F								
1000	"	4.0	D			2.1	F			1.9	J				
1500	"	5.6	D			3.2	F			2.3	J	1.9	J		
2000	"					3.6	G			2.7	J	2.2	J		
3000	"					4.3	G			3.8	J	3.2	J		
4000	"					5.8	G			7.7	J	4.3	J		
5000	"					7.5	G					7.5	J		

Chlorine g/h	Back Pressure bar	Injector Throat and Tail													
		99	*			140	*			193	*	242	*		
200	0.7	2.5	D			1.7	F								
400	"	3.3	D			2.1	F								
600	"	4.1	D			2.3	F								
1000	"	4.8	D			2.6	F			2.4	J				
1500	"	6.0	D			3.8	F			2.6	J	2.2	J		
2000	"					4.0	G			3.0	J	2.6	J		
3000	"					4.9	G			4.8	J	3.4	J		
4000	"					6.4	G			8.6	J	4.7	J		
5000	"					8.2	G					8.2	J		

Chlorine g/h	Back Pressure bar	Injector Throat and Tail													
		99	*			140	*			193	*	242	*		
200	1.4	3.3	D			2.7	F								
400	"	4.0	D			3.2	F								
600	"	5.1	D			3.4	F								
1000	"	6.6	D			3.6	F			3.0	G				
1500	"	8.3	D			4.5	F			3.9	G	2.7	J		
2000	"	10.5	D			5.4	G			4.3	G	3.3	J		
3000	"					5.8	G			5.2	H	4.3	J		
4000	"					7.1	G			6.1	J	5.4	J		
5000	"					9.3	G					9.3	J		

TYPE V10k GAS FEEDER

Chlorine	Back Pressure	Injector Throat and Tail															
		g/h	bar	99	*			140	*			193	*	242	*		
200	2.8	5.6	D			5.3	F										
400	"	5.8	D			5.4	F										
600	"	7.4	D			5.7	F										
1000	"	8.5	D			6.1	F			4.5	G						
1500	"	11.0	D			6.8	F			6.4	G						
2000	"	12.4	D			7.6	F			6.8	G						
3000	"					8.4	F			7.0	H	6.3	H				
4000	"					10.5	G			8.6	H	8.7	J				
5000	"					11.9	G					12.5	J				

Chlorine	Back Pressure	Injector Throat and Tail															
		g/h	bar	99	*			140	*			193	*	242	*		
200	4.2	8.1	D			7.6	F										
400	"	8.2	D			7.9	F										
600	"	8.9	D			8.2	F										
1000	"	10.4	D			8.5	F			6.4	G						
1500	"	13.0	D			9.1	F			8.3	G						
2000	"	13.5	D			9.8	F			9.9	G						
3000	"					10.7	F			10.2	G	8.2	H				
4000	"					13.2	F			10.6	H	9.1	J				
5000	"											13.0	J				

Chlorine	Back Pressure	Injector Throat and Tail															
		g/h	bar	99	*			140	*			193	*	242	*		
200	5.6	10.5	D			10.4	F										
400	"	10.5	D			10.5	F										
600	"	10.8	D			10.8	F										
1000	"	11.7	D			11.3	F			8.6	G						
1500	"					11.6	F			9.8	G						
2000	"					12.0	F			11.5	G						
3000	"					13.2	F			12.5	G						
4000	"					14.9	F			13.8	G	11.5	H				
5000	"					17.0	F			17.7	G	14.5	J				

TYPE V10k GAS FEEDER

Chlorine	Back Pressure	Injector Throat and Tail															
		g/h	bar	99	*			140	*			193	*	242	*		
200	7.0	13.4	D			12.5	F										
400	"	13.4	D			12.7	F										
600	"	13.7	D			13.0	F										
1000	"	14.3	D			13.2	F			10.0	G						
1500	"					13.8	F			12.3	G						
2000	"					14.5	F			13.8	G						
3000	"					15.6	F			13.9	G						
4000	"					17.5	F			14.7	G	14.5	H				
5000	"					20.0	F			19.2	G	17.4	J				

Chlorine	Back Pressure	Injector Throat and Tail															
		g/h	bar	99	*			140	*			193	*	242	*		
200	8.4	15.7	D			15.2	F										
400	"	15.8	D			15.3	F										
600	"	15.9	D			15.7	F										
1000	"	17.3	D			15.9	F			11.9	G						
1500	"					16.6	F			13.6	G						
2000	"					17.2	F			15.9	G						
3000	"					18.6	F			16.5	G						
4000	"					19.5	F			17.8	G						
5000	"									21.5	G						

Chlorine	Back Pressure	Injector Throat and Tail															
		g/h	bar	99	*			140	*			193	*	242	*		
200	9.8	18.5	D			17.2	F										
400	"	18.6	D			17.6	F										
600	"	18.9	D			17.8	F										
1000	"	19.7	D			17.9	F			13.2	G						
1500	"					18.7	F			15.7	G						
2000	"					20.2	F			17.9	G						
3000	"									18.6	G						
4000	"									19.5	G						
5000	"																

TYPE V10k GAS FEEDER

Chlorine g/h	Back Pressure bar	Injector Throat and Tail													
		99	*			140	*			193	*	242	*		
200	11.2	21.0	D			19.4	F								
400	"	21.0	D			19.8	F								
600	"	20.1	F												
1000	"	20.4	F			15.6	G								
1500	"					20.8	F			17.4	G				
2000	"									19.6	G				
3000	"									20.5	G				
4000	"									21.0	G				
5000	"														

TYPE V10k GAS FEEDER

HYDRAULIC DATA FOR 1”-INJECTOR

Part No.	Throat No.	Tailpiece	Code	Tailpiece	Code
PXE-50094	99	PXC-50093	C	PXK-50093	K
PXF-50094	120	PXD-50093	D	PXL-50093	L
PXG-50094	140	PXE-50093	E		
PXH-50094	165	PXF-50093	F		
PXJ-50094	193	PXG-50093	G		
PXK-50094	242	PXH-50093	H		
PXL-50094	312	PXJ-50093	J		

NOTE: For capacities above 10000 g/h consult Evoqua Water Technologies.

Chlorine	Back Pressure	Injector Throat and Tail															
		g/h	bar	99	*	120		140	*	165	*	193	*	242	*	312	*
200	0	1.1	D	1.0	D	1.0	F										
400	"	1.5	D	1.1	E	1.1	F										
600	"	1.6	D	1.4	E	1.1	G	1.2	F								
1000	"	2.3	E	1.7	F	1.3	G	1.3	F	1.2	H	1.0	H				
1500	"	3.2	E	2.3	F	1.8	G	1.5	H	1.5	H	1.2	J	0.9	L		
2000	"			2.7	F	1.9	G	1.7	H	1.6	J	1.4	J	1.0	L		
3000	"					3.2	G	2.1	H	1.7	J	2.5	J	1.2	L		
4000	"							3.4	H	2.5	J	2.7	K	1.4	L		
5000	"									3.1	J	2.8	K	1.4	L		
6000	"									4.5	J	3.4	K	1.8	L		
8000	"											4.8	K	2.7	L		
10000	"											11.0	K	3.7	L		

Chlorine	Back Pressure	Injector Throat and Tail															
		g/h	bar	99	*	120		140	*	165	*	193	*	242	*	312	*
200	0.2	1.6	D	1.2	D	1.2	F										
400	"	1.8	D	1.3	E	1.3	F										
600	"	1.9	D	1.6	E	1.5	G	1.3	F								
1000	"	2.4	E	1.8	F	1.7	G	1.4	F	1.3	H	1.2	H				
1500	"	3.4	E	2.3	F	1.8	G	1.7	G	1.4H	H	1.3	J	0.9	K		
2000	"			3.0	F	2.3	G	1.9	H	1.7	J	1.7	J	1.0	L		
3000	"					3.4	G	2.6	H	2.2	J	2.8	J	1.1	L		
4000	"							3.5	H	2.6	J	3.8	K	1.2	L		
5000	"									3.2	J	4.0	K	1.4	L		
6000	"									4.6	J	4.5	K	1.9	L		
8000	"											5.6	K	2.7	L		
10000	"													3.9	L		

TYPE V10k GAS FEEDER

Chlorine	Back Pressure	Injector Throat and Tail													
		99	*	120		140	*	165	*	193	*	242	*	312	*
g/h	bar														
200	0.4	1.9	D	1.5	D	1.5	F								
400	"	2.2	D	1.8	E	1.6	F								
600	"	2.3	D	2.3	E	1.8	G	1.7	F						
1000	"	3.0	E	2.5	F	2.1	G	1.8	F	1.6	H	1.5	H		
1500	"	4.1	E	2.9	F	2.2	G	2.3	H	1.8	H	1.9	J	1.2	L
2000	"			3.3	F	2.9	G	2.4	H	2.4	J	1.4	J	1.0	L
3000	"					3.2	G	2.1	H	1.7	J	2.5	J	1.2	L
4000	"							3.4	H	2.5	J	2.7	K	1.4	L
5000	"									3.1	J	2.8	K	1.4	L
6000	"									4.5	J	3.4	K	1.8	L
8000	"											4.8	K	2.7	L
10000	"											11.0	K	3.7	L

Chlorine	Back Pressure	Injector Throat and Tail													
		99	*	120		140	*	165	*	193	*	242	*	312	*
g/h	bar														
200	0.7	2.1	D												
400	"	2.8	D	2.5	E	2.1	E								
600	"	2.9	D	2.9	E	2.4	E	2.1	F						
1000	"	3.8	E	3.1	F	2.8	F	2.4	F	2.2	H	1.8	H		
1500	"	4.2	E	3.5	F	2.9	F	2.8	G	2.2	H	1.9	J	1.7	K
2000	"	5.0	E	4.3	F	3.5	F	2.9	H	2.6	J	2.4	J	1.7	K
3000	"			6.7	F	4.5	G	3.9	H	3.2	J	3.5	J	1.7	L
4000	"					6.2	G	4.1	H	3.6	J	4.3	K	1.7	L
5000	"							5.1	H	4.2	J	4.5	K	2.0	L
6000	"							6.3	H	5.2	J	5.1	K	2.5	L
8000	"									7.5	J	6.8	K	2.9	L
10000	"									8.4	J			4.7	L

Chlorine	Back Pressure	Injector Throat and Tail													
		99	*	120		140	*	165	*	193	*	242	*	312	*
g/h	bar														
200	1.4	3.2	C												
400	"	3.9	D	3.4	E	3.2	E								
600	"	4.2	D	4.0	E	3.6	E	3.2	F						
1000	"	5.3	D	4.5	E	3.8	F	3.4	F	3.2	H	3.4	H		
1500	"	5.6	E	4.9	F	3.9	F	3.7	G	3.5	G	3.4	J		
2000	"	6.7	E	5.5	F	4.6	F	3.9	G	4.4	J	3.6	J	2.8	K
3000	"					5.4	G	5.0	G	4.7	J	4.2	J	3.0	K
4000	"					7.2	G	5.4	H	5.0	J	5.1	K	3.3	K
5000	"							6.6	H	5.8	J	5.2	K	3.4	K
6000	"									6.9	J	6.2	K	3.8	K
8000	"									8.4	J	7.8	K	4.4	L
10000	"									9.3	J			6.7	L

TYPE V10k GAS FEEDER

Chlorine	Back Pressure	Injector Throat and Tail															
		g/h	bar	99	*	120		140	*	165	*	193	*	242	*	312	*
200	2.8	5.4	C														
400	"	6.3	C	5.9	D	5.5	E										
600	"	6.4	D	6.3	E	5.6	E	5.3	F								
1000	"	7.2	D	6.6	E	6.2	E	5.6	F								
1500	"	7.8	D	7.2	E	6.7	F	6.0	F	5.6	G	5.3	H				
2000	"	8.7	E	7.8	E	7.3	F	6.7	F	5.9	G	5.7	H				
3000	"			9.5	F	8.0	F	7.1	G	6.7	H	6.4	H	5.2	K		
4000	"			10.5	F	9.5	G	7.9	G	7.3	H	7.0	K	5.2	K		
5000	"					11.2	G	8.9	G	7.9	H	7.1	J	5.3	K		
6000	"							9.8	H	8.6	J	7.5	K	5.8	K		
8000	"									10.4	J	9.4	K	6.5	K		
10000	"									11.8	J			9.8	L		

Chlorine	Back Pressure	Injector Throat and Tail															
		g/h	bar	99	*	120		140	*	165	*	193	*	242	*	312	*
200	4.2	7.7	C			7.2	E										
400	"	8.5	C	7.9	D	7.6	E										
600	"	8.7	D	7.9	D	7.7	E										
1000	"	9.2	D	8.9	E	8.1	E	7.7	F			7.6	H				
1500	"	9.8	D	9.4	E	9.2	F	8.0	F	7.6	G	7.8	H				
2000	"	11.4	D	9.9	E	9.6	F	8.5	F	7.8	G	8.0	H				
3000	"	13.1	E	13.0	E	10.3	F	9.6	G	9.4	G	8.4	H	7.4	K		
4000	"			13.5	F	11.1	F	10.1	G	9.2	H	9.4	J	7.4	K		
5000	"			15.1	F	12.8	G	10.7	G	9.7	H	9.7	J	7.6	K		
6000	"							12.2	G	10.5	H	10.3	J	7.6	K		
8000	"									12.6	J	11.6	J	8.2	K		
10000	"									13.8	J			10.1	K		

Chlorine	Back Pressure	Injector Throat and Tail															
		g/h	bar	99	*	120		140	*	165	*	193	*	242	*	312	*
200	5.6	9.4	C														
400	"	10.3	C	10.0	D	10.1	E										
600	"	10.9	C	10.3	D	10.3	E	9.9	F								
1000	"	11.6	D	10.9	D	10.5	E	9.9	F	9.5	G						
1500	"	12.4	D	11.7	E	11.1	E	10.0	F	9.6	G	10.3	H				
2000	"	13.6	D	12.1	E	11.8	F	10.2	F	9.8	G	10.4	H				
3000	"	15.8	E	13.7	E	12.2	F	11.5	F	10.5	G	10.9	H				
4000	"			16.3	F	12.7	F	12.2	G	11.3	G	11.5	H	9.4	K		
5000	"					14.8	F	12.9	G	11.8	H	11.7	H	9.7	K		
6000	"							14.8	G	12.4	H	12.2	J	9.9	K		
8000	"									14.5	H	12.9	J	10.4	K		
10000	"									15.6	J			11.7	K		

TYPE V10k GAS FEEDER

Chlorine	Back Pressure	Injector Throat and Tail															
		g/h	bar	99	*	120		140	*	165	*	193	*	242	*	312	*
200	7.0	11.7	C														
400	"	12.1	C	13.0	D	11.7	E										
600	"	12.9	C	13.3	D	12.3	E										
1000	"	14.3	D	13.4	D	12.7	E	12.3	F	11.4	G	12.3	H				
1500	"	14.9	D	14.1	E	13.1	E	12.4	F	11.6	G	12.5	H				
2000	"	15.8	D	14.6	E	13.9	E	12.8	F	11.7	G	13.1	H	11.0			K
3000	"	18.9	E	16.1	E	14.9	F	13.7	F	12.1	G	13.9	H	11.5			K
4000	"			19.5	F	15.3	F	15.2	G	12.9	G	14.3	H	11.5			K
5000	"			20.6	F	16.5	F			14.0	H	14.5	H	11.5			K
6000	"									14.9	H	14.8	J	11.5			K
8000	"									16.3	H	15.4	J	12.0			K
10000	"											16.5	J	14.0			K

Chlorine	Back Pressure	Injector Throat and Tail															
		g/h	bar	99	*	120		140	*	165	*	193	*	242	*	312	*
200	8.4	13.9	C														
400	"	14.1	C	14.7	D												
600	"	14.8	C	14.8	D	14.4	E										
1000	"	16.7	D	14.9	D	14.5	E	14.6	F	13.8	G	14.0	H				
1500	"	17.3	D	16.2	E	14.6	E	14.7	F	13.8	G	14.3	H				
2000	"	18.6	D	16.9	E	15.5	E	14.8	F	13.9	G	14.6	H				
3000	"					17.4	F	16.2	F	14.1	G	14.9	H				
4000	"					17.8	F	17.4	F	14.9	G	15.3	H	14.0			K
5000	"							17.7	G	15.7	G	15.7	H	14.1			K
6000	"									16.8	G	16.1	J	14.1			K
8000	"									17.9	H			14.5			K
10000	"													15.8			K

Chlorine	Back Pressure	Injector Throat and Tail															
		g/h	bar	99	*	120		140	*	165	*	193	*	242	*	312	*
200	9.8	15.9	C														
400	"	16.0	C														
600	"	17.2	C	17.2	D	16.4	E	16.7	F								
1000	"	19.0	D	17.8	D	16.6	E	16.8	F	15.5	G						
1500	"	19.4	D	18.6	E	16.9	E	17.1	F	15.6	G						
2000	"			19.2	E	18.7	E	17.3	F	15.9	G						
3000	"					19.9	F	17.9	F	16.4	G	17.9	H				
4000	"							19.3	F	16.6	G	18.7	H	17.0			K
5000	"									17.5	G	19.0	H	17.1			K
6000	"									19.4	G	19.4	J	17.3			K
8000	"													17.9			K
10000	"													18.5			K

TYPE V10k GAS FEEDER

Chlorine g/h	Back Pressure bar	Injector Throat and Tail													
		99	*	120		140	*	165	*	193	*	242	*	312	*
200	11.2	17.9	C												
400	"	18.2	C	18.4	D	19.2	E								
600	"	18.9	C	18.8	D	19.8	E	19.8	F						
1000	"			19.5	D	21.0	E	19.9	F	18.2	G	19.6	H		
1500	"							20.0	F	18.2	G	20.1	H		
2000	"							20.1	F	18.4	G	20.6	H		
3000	"							20.3	F	18.6	G			20.0	K
4000	"							19.3	F	18.7	G			20.2	K
5000	"									21.0	G			20.5	K
6000	"													21.0	K
8000	"														
10000	"														

TYPE V10k GAS FEEDER

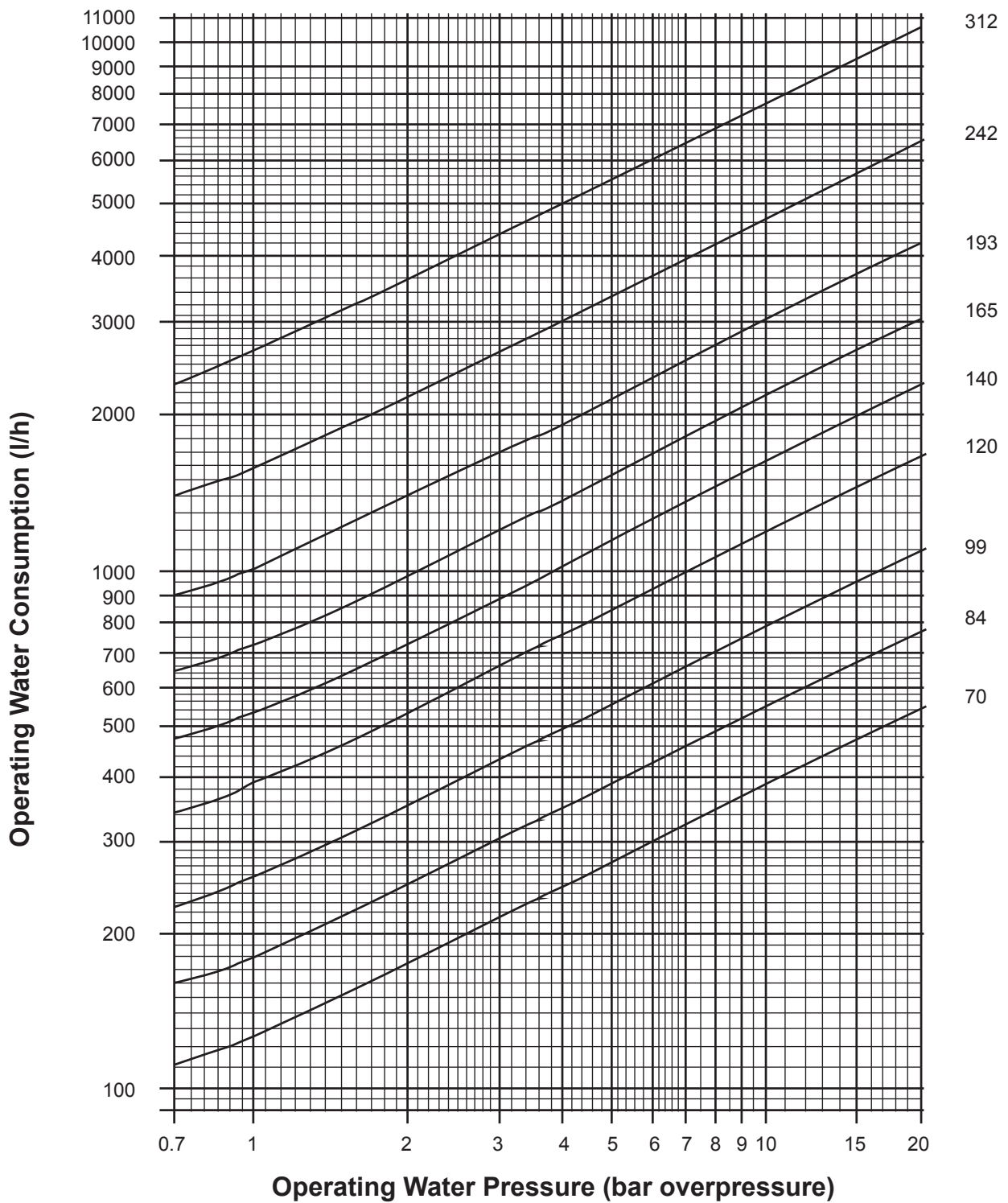

DEMAND VALVE MAINTENANCE

S10k Overhaul Kit Part No. AAA1160 / W3T291488

1 MAINTAINING THE S10k DEMAND VALVE

This supplement contains information on maintaining the S10k Demand Valve in good working order. It describes dismantling, servicing, reassembling the valve and includes illustrations and parts lists.



WARNING: Hazardous gas is present in this equipment during normal operation. To avoid possible severe personal injury or damage to equipment, read this instruction manual before reconnecting this plant to a supply of gas.

1.1 Preventative Maintenance

Maintenance of this equipment must be restricted to trained, qualified personnel who are completely familiar with these instructions.

General precautions simplify maintenance and help to prevent equipment failure. These precautions are easy to accomplish and will minimise repairs by providing good operating conditions.

NOTE: If the gas feeder is used seasonally (long term shut-down) then the cleaning procedure should be performed prior to start-up.

Recommended Cleaning Interval for Vacuum Demand Valve:-

When the S10 demand valve is in continuous operation it should be serviced annually. When operation of the S10k is on a stop/start basis and is mounted on a cylinder it should be serviced every six months.

NOTE: The actual frequency of cleaning will depend on calendar time, the feed rate and the amount of gas fed, the care exercised in cylinder changing, the source of gas and the quality of operating water.

Operating experience is the best guide to preventative maintenance and may result in significant variations from the recommended schedule.

1.2 Checking for Gas Leaks



WARNING: To avoid possible severe personal injury or equipment damage, no leaks should be tolerated. They always get progressively worse and must be promptly corrected. It is good practice to have an approved positive pressure breathing set available when making leak checks.

Check daily for signs of leaks - refer to the gas leak test that is detailed in the following Section 2.4. Eliminate any leak before proceeding. Green or reddish deposits on metal parts indicate gas leaks. There should be no evidence of gas odour around the equipment except when a joint is temporarily opened.

1.3 Moisture



CAUTION: When any connection is broken, even for a short time, immediately plug the resultant opening with a rubber stopper or equivalent to prevent the entrance of moisture. Moisture must be excluded from any part of the equipment which is normally exposed to dry gas only. While dry gas is non-corrosive, moist gas is extremely corrosive to common metals such as brass or steel.

1.4 Plastics Parts

Whenever threaded plastic parts are assembled, use Teflon tape or Halocarbon grease on threads to prevent parts freezing together. In general do not use tools to make up plastic connections, but rather make this type of connection by hand.

1.5 Gaskets and O-rings

A supply of gaskets and O-rings should be kept on hand so that all gasketed joints can be maintained in proper condition. Regular replacement of gaskets will minimise operating difficulties and this practice is recommended. The preventative maintenance kit includes a set of gaskets.



WARNING: To avoid possible severe personal injury or equipment damage, never re-use gaskets. Always replace with a new gasket of the proper size and material as identified on the equipment drawing.

1.6 Cleaning

If the valve seats become contaminated with impurities sometimes found in gases, they should be removed and cleaned.



WARNING: All cleaning should be carried out in an open area or in a well ventilated room.

- 1 Most of the residue that accumulates can usually be removed with warm water and a detergent.
- 2 If further cleaning is necessary, metal, glass and ceramic parts may be washed in a suitable solvent. Plastic and hard rubber parts should be cleaned only with warm water and a detergent, followed by methylated spirits (if necessary).



WARNING: Carbon tetrachloride is a satisfactory cleaning agent but its use is not recommended because of the possible toxic effect of exposure to its fumes. Do not use wood alcohol, ether, petrol or petroleum distillates.

- 3 Parts that come into contact with gas must have all traces of solvent and moisture removed from them before they are returned to service. Do not use heat on plastic or hard rubber parts.

1.7 Tools

When working with screws, bolts, nuts and other hardware, use the correct size tool to avoid damage. This precaution will make it easier to remove the components when necessary.

2 SERVICING THE VACUUM DEMAND VALVE (FIG.1)

2.1 Shutdown for Servicing



WARNING: In the following procedure, which must be carried out before servicing any gas feeder system, a gas line is disconnected with a possible release of gas. It is recommended that self contained, positive pressure, breathing apparatus is worn.

- 1 Isolate the vacuum demand valve from its gas supply (i.e. shut the main cylinder valve for a cylinder mounted regulator or the appropriate header valve for multiple demand valve arrangements). Wait until the OUT-OF-GAS indicator shows all red and the float rests on the bottom stop of the flowmeter.
- 2 Slacken the connection between the vacuum demand valve and its gas isolating valve. Air is now drawn through the valve and into the system to purge any remaining gas.
- 3 After at least 3 minutes re-tighten the connection, set the demand valve to OFF and turn off the water supply to the injector.
- 4 Release any pressure build-up in the solution delivery line (refer to WARNING in Section 2.7.4 of the main instruction manual). If need be, protect against frost by draining the water supply and solution delivery pipelines.

2.2 Disconnecting the Vent Line



WARNING: Any vertical section of the vent tube may contain chlorine gas/condensate.

- 1 Pinch the vent tube at its lowest point and then disconnect it from the demand valve.
- 2 Remove and plug the open end. If necessary clear the vent tube by passing dry air through it, or allow the tube to drain/vent into the room under controlled conditions.

2.3 Removing the Demand Valve

- 1 Loosen the union nut and disconnect the vacuum tubing from the demand valve outlet. Plug the tube with a rubber stopper to prevent the entrance of air and moisture while the valve is being cleaned.
- 2 Loosen the yoke screw and remove the entire vacuum demand valve to a location where the work is to be done. Cap the gas supply container valve outlet while they are not in use.
- 3 Remove the inlet nipple (25).

- 4 Remove retainer (26), spring (23) and first check valve stem (22). Then remove the stem guide (29), spring (21) and the second check valve stem (20) from housing (27).
- 5 Grip the inlet nipple and seat assembly with suitable tongs and hold it under hot running water (approx. 54 to 56°F) to soften and flush away deposits. If running hot water is not available pour hot water, as from a kettle, in the same manner. Detergent may help loosen stubborn deposits.



CAUTION: Do not scrape or damage the hole in the Teflon seat as this could destroy the seat shape and stem seating surface.

- 6 Remove all traces of detergent and moisture from the parts before returning them to service. Do not use heat on plastic parts.
- 7 Clean the valve stems, springs, retainer, and guide using hot water (an old tooth brush is a useful scrubbing tool on these parts). Do not use a knife or scraper on the conical part of the valve stem. Use paper towel or a clean rag to wipe and dry the parts.
- 8 Thoroughly dry all parts of the valve before reassembly. Warming parts is the most effective way of drying them.



CAUTION: The mesh screen (24) must be inserted into the spring retainer (26) before the PTFE filter . If these items are placed in the wrong order the filter may be pulled into the valve by the vacuum.

NOTE: Always use a new screen and filter after servicing the valve.

- 9 Install stems with cones toward the Teflon seats. Install springs, retainer and guide. Renew its O-ring and refit inlet nipple.
- 10 Apply a few drops of oil where the yoke screw enters the clamp and a dab of grease on the yoke screw thread to facilitate clamping.
- 11 Return the assembled vacuum demand valve to the gas supply container valve on which it is to be used. Install a new filter and lead gasket on the nipple and tighten the yoke screw securely.
- 12 Remove any temporary plugs and refit the gas vacuum line and the vent line to their respective connections.
- 13 Turn the knob to OFF and check for gas leaks before returning to service.

2.4 Testing for Gas Leaks



WARNING: In the following procedure, chlorine gas is introduced into the system and all pressure joints are tested for leaks. It is recommended that breathing apparatus is worn during this procedure.

NOTE: Testing for chlorine or sulphur dioxide gas leaks is accomplished by using a puffer bottle (W&T Part No. U86151), containing a 10% ammonia solution, to introduce ammonia fumes to the area under test. Any escaping gas will combine with the ammonia to form dense white clouds of ammonium chloride.



WARNING: Before commencing this procedure, ensure that the injector associated with the gas feed system is operational, i.e. that the injector is operating correctly and can be started immediately a gas leak is detected. On automatically controlled units select the manual mode of operation. If a leak of gas is detected, close the storage cylinder or header valves and start up the injector immediately. Open all other valves in the gas supply line, including the vacuum demand valve, to evacuate any gas from the system. Rectify the leak and re-start the procedure.

- 1 Activate the gas warning device.
- 2 Make sure the vacuum demand is set to 'OFF' and that all valves in the gas supply line are closed.
- 3 Ensure the auxiliary cylinder valve (if used) is closed and crack open the main cylinder valve. Test for leaks around the valve assembly as detailed in the NOTE above. If there are no leaks, open the main cylinder valve one turn.
- 4 Open the auxiliary cylinder valve (if used) and then close it again and test for leaks, to the next valve in the system. If there are no leaks, fully open the auxiliary cylinder valve.
- 5 Continue until each valve up to the vacuum demand valve is tested.

TYPE V10k GAS FEEDER

KEY	PART No.		QTY	DESCRIPTION
	OLD	NEW		
-	AAA.6216‡	—	1	Vacuum demand valve, (Universal yoke)
-	AAA.6219‡	—	1	Vacuum demand valve, (Chlorine Inst. yoke)
1	ALI.5542	W2T367059	1	'O' ring
2	AMK.5553	W2T11346	1	'O' ring
3	APQ.5558	W2T367120	2	'O' ring
4	AOK.4480	W2T11501	1	Front housing
	AMG.4473	W2T11506	1	Front housing, switchover
5	APQ.4366	W2T11061	1	Retainer
6	ANI.4524	—	1	Pawl
	ARC.4010	—	1	Pivot pin
	P.41078	W2T376033	1	Pawl spring
7	ARQ.4529	W2T11513	1	Knob
8	ACE.4534*	—	1	Operating lever, switchover
8A	AMK.5341†	W2T11210	1	Operating lever, standard
9	AMG.4473*	W2T11506	1	Front cover, switchover
9A	AKG.5438†	W2T11240	1	Front cover, standard
	AQC.3487	—	1	Screw (both covers)
10	ALI.5386	—	1	Operating shaft
	APQ.5390	W2T11227	1	Operating shaft, Ammonia only
11	AQO.4543	W2T11508	1	Backing plate
12	P.52090	W2T15128	1	Pipe plug, 1/2" NPT
13	AAA.1616	W2T11006	1	Backing diaphragm
14	AUK.3460	—	6	Screw
15	AJA.4495	—	1	Back housing
16	APQ.5464	W2T11455	1	Operating diaphragm
17	ASS.4538	W2T11507	1	Nut
	P.51401	W2T15248	1	'O' ring
18	ALI.5399	—	1	Nut, housing retainer
19	AMK.5469	—	1	Seat, second check valve
	P.51399	W2T15247	1	'O' ring
20	AIC.5321	W2T367016	1	Stem, second check valve
21	AKG.4105	W2T11199	1	Spring, second check valve
22	ANM.5366	W2T367090	1	Stem, first check valve
23	APQ.4110	W2T11229	1	Spring, first check valve
24	AAA.1328	—	1	Screen
25	AAB2291	W2T10012	1	Nipple
	AAA.6225	W2T633350	1	Nipple, Ammonia only
	AKG.5549	W2T367045	1	'O' ring
26	AIC.5355	W2T11202	1	Retainer
	AAA.6831	W2T633398	1	Retainer, Ammonia only
27	AAA.7641	—	1	Housing, second check
	AMK.5655	W2T11347	1	O - ring
	AJE.5446	—	1	Housing, Ammonia only
28	AAA.1271	—	1	Seat, first check valve
	APQ.5558	W2T367120	1	'O' ring
29	ANM.5301	—	1	Guide, second check valve
30	ANM.4367	—	1	Vent connection
	PXB.39234	W3T169111	1	Nut
	RP.68-4468	—	-	Tube, 1/4" x 3/8" od
31	ANM.5434	—	1	Diaphragm
32	P.41079	W2T18114	1	Plunger
33	AIA.4045	W2T11216	1	Spring
34	APM.4519	W2T11505	1	Plug
-	AHS.4646	W2T11124	1	Warning label
-	ACG.4723	W2T11144	1	Warning label, Ammonia

‡ This assembly excludes the front cover parts which make up either the STANDARD unit (comprising items marked thus †) or the SWITCHOVER unit (comprising items marked thus *)

IMPORTANT: When ordering spare parts quote machine serial number together with full description and part number.

FIG.1 VACUUM DEMAND VALVE

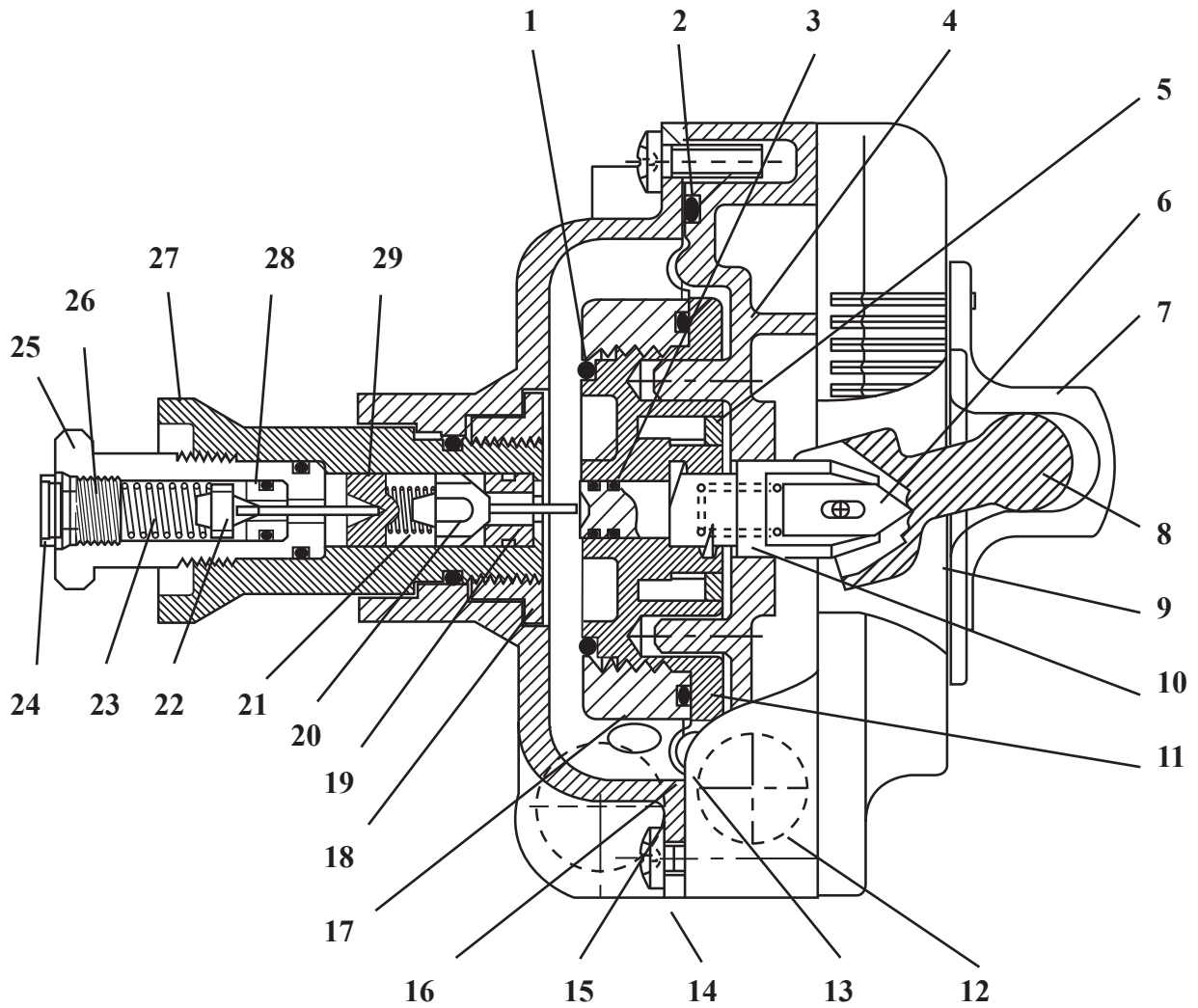

PRESSURE RELIEF VALVE

NOTE: The Vacuum Regulator Unit MUST have a pressure relief valve if the control unit is coupled directly to the Regulator.

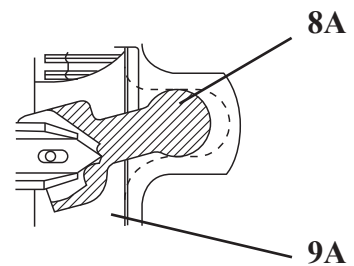
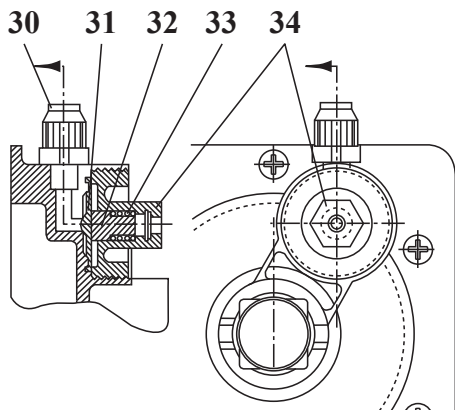

FIG.1 VACUUM DEMAND VALVE

ACTIVATED CARBON FILTER

The activated carbon filter absorbs small amounts of chlorine gas from the vacuum regulator vent.

The activated carbon filter should be mounted vertically with the bottom of the unit approx. 200mm above floor level.

As soon as the activated carbon is saturated, chlorine gas is discharged from the underside of the filter housing. Chlorine gas odour is then detectable and the gas detector (option) installed in the room is triggered. In this case, and regularly once a year, replace the activated carbon filter (refer to the instructions on the plate on the filter housing, the servicing instructions and spare parts).

Replacing the Activated Carbon Filter



WARNING: Contaminated activated carbon reacts with water forming an acid. Never immerse it in water or pour water over it, but neutralize it first (as described below). Wear a gas mask and protective clothing (rubber apron and rubber gloves).

The activated carbon needs to be replaced as soon as it smells of chlorine (or sulphur dioxide) or is lumpy.

- 1 To replace the activated carbon, unscrew and carefully open the activated carbon filter.
- 2 If there is no smell of gas, stir the activated carbon powder and porcelain rings to check for lumps. If the activated carbon is still OK, close the filter housing again and re-tighten.

Activated carbon contaminated with chlorine

- 1 Take the activated carbon filter out into the open air.
- 2 Dissolve 300 g of sodium thiosulphate (part No. U-94054) in approx. 8 l of water.
- 3 Unscrew the upper cap.
- 4 Carefully pour the contaminated activated carbon into the sodium thiosulphate solution.
- 5 Dilute with several litres of water and dispose of down the drain.
- 6 Dispose of the ceramic rings and the activated carbon (e.g. as commercial waste).

TYPE V10k GAS FEEDER

- 7 Fill the filter housing with fresh activated carbon and ceramic rings (part No. U-93882) and screw on.

Activated carbon contaminated with SO₂

Repeat the procedure as described above, except use sodium hydroxide (obtained locally) to neutralise the activated carbon.

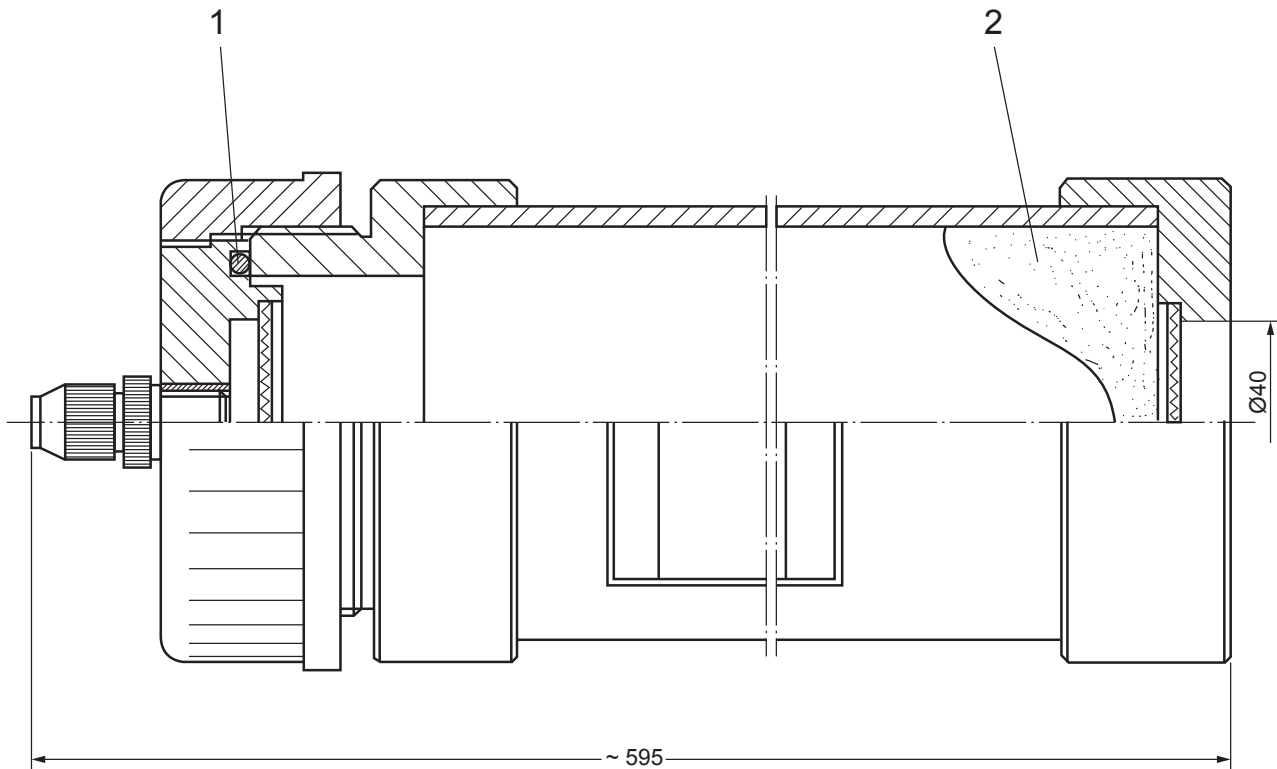

Item	Part No. (old)	Part No. (new)	Description	Qty
1	P.100376	—	O-ring d59.69x5.33/EPDM	1
2	U.93882	W3T161729	Activated carbon mixture 2,500ml	1
*)	U.94054	W3T163644	Sodium thiosulphite	300 g

*) Needed to neutralise activated carbon contaminated with chlorine.

Evoqua Water Technologies Aftermarket Support and Service

INTRODUCTION

Every day, millions of people and thousands of companies rely on Evoqua Water Technologies to help them meet their needs for clean water.

As the leading global provider of chemical dosing, metering, disinfection, chlorination, filtration, deionisation and electrochlorination products, Evoqua Water Technologies provide systems and process technology for water treatment in the municipal, industrial and the leisure industries.

AFTERMARKET SUPPORT AND SERVICE

Meeting our customers needs is our highest priority. In addition to supplying the products you need, we also offer a full range of aftermarket support and service options. Our dedicated team of highly skilled engineers are committed to providing a first class service to our customers.

Getting the correct level of aftermarket support and service can ensure that your plant runs as efficiently as possible by preventing breakdowns and minimising plant downtime.

Our modular flexible approach ensures that our aftermarket support and service offering can be tailored to meet your exact requirements, our offering includes:-

- Technical Assistance
- 24 Hour Telephone Support
- Breakdown Cover
- Maintenance Contracts
- Planned & Preventative Maintenance Programs
- Call-Out Service
- Supply of Spare Parts and Critical Spares
- System Refurbishments & Upgrades

CO-ORDINATION

Evoqua Water Technologies dedicated Customer Service Department is co-ordinated from our Derby office.

Tel: - 0845 450 2882

customerservice.uk@evoqua.com

COMMISSIONING

Following installation, our team of commissioning engineers are responsible for the safe handover of the equipment from ourselves to the new owner guaranteeing its operability in terms of performance, reliability and safety.

All our commissioning engineers undergo a comprehensive training programme on our products and the latest industry and health and safety standards.

In our team we have commissioning engineers who are trained to work in all industry sectors both on shore and offshore.

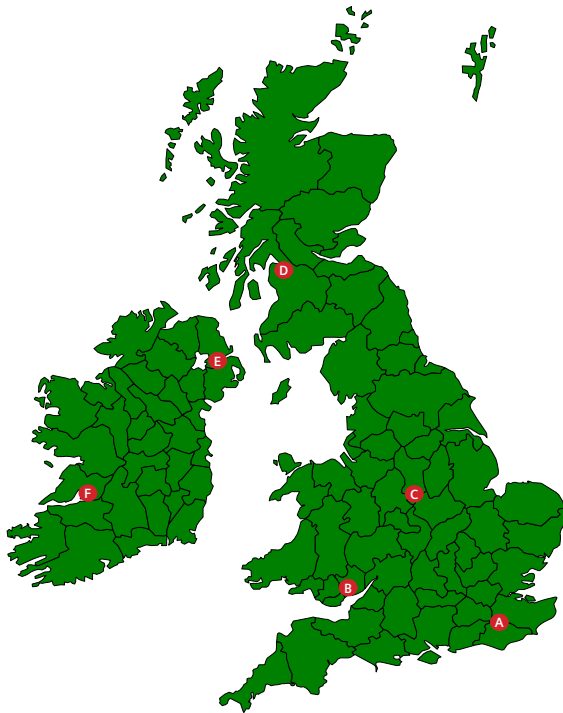

FULL COVERAGE UK & IRELAND

Over the years we have been able to grow our aftermarket support and service operation considerably. To ensure our customers get the very best support and shortest response times our engineers and support staff are strategically located across the country, to give us the very best coverage of the whole of the UK & Ireland.

- A - Sevenoaks, Kent
- B - Caldicot, Gwent
- C - Little Eaton, Derbyshire
- D - Kirkintilloch, East Dunbartonshire
- E - Belfast, Northern Ireland
- F - Limerick, Ireland

Did you know?

Evoqua Water Technologies has over 200 current service and maintenance contracts in mainland UK & Ireland and carry out over 2000 site visits per year

Did you know?

Our skilled engineers carry work in all industries including; life sciences, food & beverage and leisure

TRAINING

Evoqua Water Technologies understands the importance of training to our customers; receiving the correct training can ensure that you get the optimum performance out of our equipment and your plant.

Our team of qualified trainers can put together bespoke training solutions tailored to suit your needs. This could either be classroom based, or hands-on operator training, conducted onsite or at one of our locations around the country.

We have also found training creates stronger links with our customers and it gives us a better opportunity to understand each others requirements.

CONTACT

Evoqua Water Technologies have service centres all over the world. Please see the contacts table below to find a centre closest to you.

Country	Email	Telephone
Australia	info.au@evoqua.com	+61 (0) 3 8720 6597
Canada	canadainfo@evoqua.com	+1 905 944 2800
Germany	wtger@evoqua.com	+49 8221 9040
Singapore	infosg@evoqua.com	+65 6830 7100
USA	wtus@evoqua.com	+1 856 507 9000
UK	info.uk@evoqua.com	+44 0845 450 2882



One60 London Road, Sevenoaks, Kent, TN13 1BT, United Kingdom

Tel: +44 (0) 1732 771777 Email: info.uk@evoqua.com

www.evoqua.com

Wallace & Tiernan, Ionpure and Memcor are trademarks of Evoqua, its subsidiaries or affiliates, in some countries.

All information presented herein is believed reliable and in accordance with accepted engineering practices. Evoqua makes no warranties as to the completeness of this information. Users are responsible for evaluating individual product suitability for specific applications. Evoqua assumes no liability whatsoever for any special, indirect or consequential damages arising from the sale, resale or misuse of its products.

© 2014 Evoqua Water Technologies Ltd Subject to change without notice