



evoqua
WATER TECHNOLOGIES



WALLACE & TIERNAN[®] GAS MONITORING SYSTEM GMS PLUS

INSTRUCTION MANUAL



Please note

Original instruction manual!



Contents

1.	Introduction	5
1.1	Documentation	5
1.2	Conventions	6
2.	Safety	7
2.1	Intended use	7
2.2	General safety instructions	8
2.3	Safety instructions specific to the unit	9
2.4	Warranty conditions	10
2.5	AGW-Values (Occupational exposure limit)	10
3.	Description	11
3.1	Technical data	11
3.2	Scope of supply	15
3.3	Description	15
4.	Functions	21
4.1	Application	21
4.2	General	22
4.3	Alarms	24
4.4	Interfaces	30
4.5	Door contact switch	32
4.6	Temperature measurement (Pt1000 sensor)	33
4.7	mA outputs	34
4.8	Power fail output	34
4.9	Test function	35
4.10	Battery supply (optional)	36

5.	Installation	39
5.1	Transport and storage	39
5.2	Installing the gas monitoring system GMS plus	40
5.3	Commissioning the Chloratect sensor	48
5.4	Adjusting the span with comparative measurement and function test	50
5.5	Commissioning the mA sensor	57
5.6	Commissioning	59
5.7	Shutdown	66
5.8	Change batteries (battery supply option)	67
6.	Operation	69
6.1	Display and operating elements	69
6.2	Notes on operation	71
6.3	Errors and remedies	90
7.	Maintenance	95
7.1	Routine maintenance	95
7.2	Electrolyte supply for Chloratect sensors	96
7.3	Replacing a fuse or battery	97
7.4	Recommended spare parts	99
8.	Accessories and spare parts	101
8.1	Gas monitoring system GMS plus	101
8.2	Chloratect sensors and sensor kits	101
8.3	mA sensors and sensor kits	102
8.1	Temperature sensors und sensor kits	102
9.	Wiring diagrams	103
10.	Declaration of conformity	109

1. Introduction

1.1 Documentation

1.1.1 Target groups

This instruction manual provides the information for installation, operating and maintenance personnel. It is required for operation and maintenance of the unit.

This instruction manual is intended for the operating personnel. It contains important information for safe and reliable, trouble-free and economical operation of the unit. Observation of this information helps to prevent danger, lowers repair costs, reduces down-times, and also increases the reliability and service life of the unit.

The chapter "Installation" is intended for trained and qualified service personnel only. It contains important information on installation, configuration and commissioning of the unit.

All persons working with the unit must have read and understood the instruction manual, particularly the safety instructions it contains.







Please consult the table of contents and the index to quickly locate the chapter you are looking for.

1.2 Conventions



Please note

This instruction manual contains a number of notes with different priorities which are marked with symbols.

Picto-gram	Note	Meaning
	<i>Danger!</i>	Immediate danger to life and limb! If the situation is not handled properly, death or serious injury is the result.
	<i>Warning!</i>	Danger to life and limb! If the situation is not handled properly, death or serious injury may be the result.
	<i>Attention!</i>	If this warning is not observed, medium or slight injury or damage to the equipment may be the result.
	<i>Warning!</i>	This symbol warns against parts carrying dangerous electrical voltages. Risk of fatal injury!
	<i>Please note</i>	These notes facilitate work with the system.
	<i>Attention!</i>	Environmental hazard! Do not throw away or burn the batteries! Batteries must be disposed of at a collection point for chemical waste.

2. Safety

2.1 Intended use

The gas monitoring system GMS *plus* continuously measures the concentration of gas (e.g. chlorine, chlorine dioxide, ozone, etc.) and the temperature in rooms. The GMS *plus* sends an optical or acoustic warning signal as soon as a set limit value has been exceeded.

The GMS *plus* may only be used in rooms and under the operating conditions described in the technical data.

The operational safety of the unit is only guaranteed if it is used in accordance with its intended application. The unit may only be used in accordance with its intended application as defined in the order and under the operational conditions stated in the technical specifications.

Compliance with the intended use also includes reading this instruction manual and observing all the instructions it contains. Intended use also means that all inspection and maintenance work must be performed at the prescribed intervals.

The operator bears full and sole responsibility if this unit is put to any use which does not comply strictly and exclusively with this intended use.

2.2 General safety instructions

Evoqua Water Technologies GmbH places great emphasis on safety when working on or with the unit. Safety is our guiding principle right from the design phase; the system is therefore equipped with safety features.

Safety instructions

The safety instructions in this documentation must be observed unconditionally at all times. Additional industry-wide or in-house safety regulations also continue to apply.

Safety notes printed on the unit

All safety instructions attached to the unit itself must be observed. These instructions must always be clearly legible and complete.

State-of-the-art technology

The unit has been constructed in accordance with state-of-the-art technology and the accepted safety regulations. However, if the unit is used by persons who have not been adequately instructed, risks to life and limb of such persons or third parties and damage to the unit itself or to other property cannot be ruled out. Work not specifically described in this instruction manual may only be performed by authorized personnel.

Personnel

The operator of the overall system must ensure that only authorized and qualified specialists are permitted to work with and on the unit within their defined scope of authority. "Authorised and specialised personnel" refers to trained technicians of the operator, of Evoqua Water Technologies GmbH and, if applicable, of the service partner. All work on electrical components must be performed by qualified electricians only.

Spare parts / components

Trouble-free operation of the unit is only guaranteed if original spare parts and components are used in precisely the combination described in this instruction manual. Failure to observe this instruction may incur the risk of malfunction or damage to the unit.

Extensions and conversions

Never attempt to perform any modifications, extensions or conversions on the unit that could have an adverse affect on safety without the written approval of the manufacturer.

Electrical power

During normal operation, the housing must remain closed.

Prior to installation, inspection, maintenance and repair work, always switch the unit off by the main switch on the outside of the unit and secure against reactivation.

Connect all cables in accordance with the wiring diagram.

Disposal

Ensure that auxiliary materials and replaced parts are disposed of in a manner that is safe and environmentally benign.

2.3 Safety instructions specific to the unit

Notes for the operator

- This instruction manual and the technical documentation of the installed components of the unit must always be available at the installation site!
- Always observe any supplementary, generally valid legal regulations or other binding rules and ensure their compliance! These rules and regulations apply to:
 - work safety
 - accident prevention
 - environmental protection
 - hygiene
 - first-aid
- All personnel charged with installation, commissioning, operation, maintenance and repair of the unit must read and understand this instruction manual, particularly the safety instructions!
- Never attempt to perform any modifications, extensions or conversions on the unit which could have an adverse affect on safety without the written approval of the manufacturer!
- Only use spare parts which have been approved by the manufacturer. This is always guaranteed when original spare parts are purchased.
- Always observe the intervals for regular maintenance or inspection work which are either prescribed or stated in the instruction manual.
- Never use corrosive cleaning agents!
Use only a damp cloth to clean the unit.

Notes for operating personnel

- Always read the instruction manual, in particular the safety instructions, before you operate the unit for the first time!
- Never employ any working methods which could endanger safety!
- Always comply with the prescribed values for connection voltage as well as ambient and operating conditions!
- Never deactivate any safety features!
- During operation of the unit, unexpected incorrect functions may occur that result from failure or errors in the control system. In the event of such safety-relevant changes in the operating performance of the device, switch it off immediately and remedy the fault or have it remedied immediately!
- Even when the unit is switched off, external voltage may still be applied.
- In the event of a fire, always switch the unit off with the main switch on the outside of the unit or with the external main circuit breaker or fuse!

2.4 Warranty conditions

The following must be observed for compliance with warranty conditions:

- Installation, commissioning by Evoqua Water Technologies GmbH technicians or trained and authorised specialised personnel, e.g. of contracted companies
- Intended use
- Observing the operational parameters and settings
- The unit may only be operated by trained personnel.
- The unit must not be exposed to frost (while running).
- Maintenance work must be executed by operating personnel
- Use of original spare parts

If any of the above conditions are not met, the warranty is revoked.

2.5 AGW-Values (Occupational exposure limit)

		$\text{cm}^3/\text{m}^3 = \text{ppm}$	Equivalent to mg/m^3
Chlorine	Cl_2	0.5	1.5
Chlorine Dioxide	ClO_2	0.1	0.28
Ozone	O_3	0.1	0.20

3. Description

3.1 Technical data

3.1.1 Gas monitoring system GMS *plus*

Accuracy	0.5 % based on the measuring range-end value
Ambient temperature	0 – 50 °C
Environment	No direct sunlight
Atmospheric pressure	75 – 106 kPa
Storage temperature	-20 to +70 °C
Noise emission	< 45 dB (without alarm)
Power supply	200 – 240 V AC \pm 10 % 50/60 Hz 15 VA Fuse 0.63 A (T) 100 – 120 V AC \pm 10% 50/60 Hz Fuse 0.63 A (T) 24 V DC in accordance with EN 61131 (18 – 30, 2 V) 15 W Fuse 1.6 A (T)
Relay outputs	Switching values: 5 A, 250 V AC, 1250 VA max. 5 A, 220 V DC, 150 W max. UL/CSA rating: 5 A1/6 HP 125, 250 V AC 5 A 30 V DC 30 W max. 1 A 30 V DC - 0.24 A 125 V DC
Digital inputs	3x for switch contacts (voltage-free) < 100 Ohm Plus 2x in 24 V units together with battery supply Do not supply voltages to the digital inputs.

Analog outputs	3x 4 – 20 mA, not electrically isolated, impedance < 600 Ohm
Interface	RS232/RS485, not electrically isolated For connection to: Process Monitoring System OPC Server Data Access V2.0 Optional RS232 to connect a printer
Dimensions	320 x 270 x 175 mm (W x H x D)
Weight	5 kg incl. packaging
Enclosure	IP 66
Display and operating unit	1 x operating panel with 6 keys 8 x red LED to display alarm states 1 x green LED to display power supply 1 x display 2 x 16 characters, self-luminous

3.1.2 Sensors

*Chloratect sensors for
Chlorine, chlorine dioxide and
ozone*

Measuring range	Chlorine (Cl ₂):	0 – 5 ppm 0 – 20 ppm
	Chlorine dioxide (ClO ₂):	0 – 5 ppm 0 – 20 ppm
	Ozone (O ₃):	0 – 1 ppm
Sensor cable	Length 2 m (standard) Optional extension: max. 100 m	
Dimensions	Ø 35 x 110 mm	
Enclosure	IP 20	
Operating position	Vertical ± 15 °	
Measurement uncertainty	± 5 % (under laboratory conditions) ± 15 % without span adjusting	
Measurement setting time	30 sec. for 60 % of end value	
Storage temperature	-20 – 50 °C (without electrolyte)	
Operating temperature	5 – 50 °C	
Temperature changes	max. 5 C/h	

For technical data, see corresponding sensor data sheet.

Passive 4 – 20 mA sensors

Pt1000 temperature sensors

Measuring range	0 – 50 °C
Sensor cable	Length 0.9 m (standard) Optional extension: max. 100 m
Dimensions	Ø 15 x 45 mm
Enclosure	IP 66

3.1.3 Battery supply (optional)



Please note

Only possible together with 24 V GMS *plus* gas monitoring system.

Power supply	98 – 264 V AC 47 – 63 Hz
Dimensions	250 x 180 x 165 (W x H x D)
Cable length	1.5 m (do not lengthen)
Enclosure	IP 66
GMS <i>plus</i> operating duration in a case of a power failure	min. 10 h The operating duration is less with additionally connected consumer units!
Battery life	Approx. 2 – 3 years
Storage temperature	0 – 50 °C
Operating temperature	0 °C to 45 °C
Output voltage	19.8 – 26.4 V DC ± 0.4 %
Output current	max. 2 A
Insulation	Overvoltage category 2 Contamination level 2
Battery type	Lead battery (maintenance-free)
Fuse protection	Battery load circuit 3 AT
Max. back-up fuse	5 A
Other outputs	Power ok Battery ok Charging voltage temperature tracking
Battery circuit test	1 per minute
Battery temperature monitor	> 45° => battery error

3.2 Scope of supply



Please note

Please find order numbers in Chapter 8. "Accessories and spare parts" on page 101.

3.2.1 Standard

The scope of supply includes the following, depending on the individual order:

- Gas monitoring system GMS *plus*

3.2.2 Options

- Chloratect sensors for chlorine, chlorine dioxide and ozone
- Passive 4 – 20 mA sensors
- Sensor connection cable
- Pt1000 temperature sensors
- Battery supply for 24 V

3.3 Description

3.3.1 Versions

The gas monitoring system GMS *plus* exists in three voltage variations:

- 200 – 240 V AC 50/60 Hz
- 100 – 120 V AC 50/60 Hz
- 24 V DC acc. to EN 61131 (18 – 30, 2 V)

3.3.2 Design

Gas monitoring system GMS *plus*

In the gas monitoring system GMS *plus*, up to two Chloratect sensors and/or up to two mA sensors as well as two Pt1000 sensors may be connected.

The following are integrated into the cover (A):

- A green LED (B) to indicate the power supply
- Display 2 x alarm message sensor I (C)
- Display 2 x alarm message sensor II (D)
- Display 3 x common alarm (E)
- Display sensor error (F)
- Operator controls (G)
- 2 x 16 character LCD display (H).



- A Cover
- B Green LED (power)
- C Alarm message sensor I
- D Alarm message sensor II
- E Common alarms
- F Sensor error
- G Operator controls (keys)
- H LCD display

The gas monitoring system GMS *plus* consists of a plastic housing with removable cover.

The following are installed in the gas monitoring system GMS *plus*:

- Program memory (A)
- Battery for real-time clock (B)
- 115/230 V Mains selection switch (C)
- Fuses (D)
- Terminal strips for outputs (E)
- Cable terminal screws (F)
- RS232 interface (G)
- Connections for sensors, digital inputs, interface and mA outputs (H)
- Display connection (I)

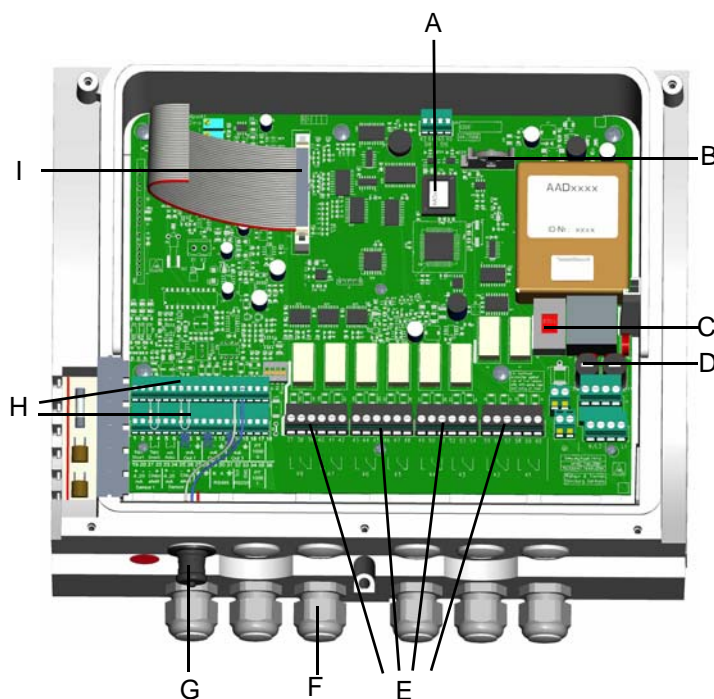

- A Program memory
- B Battery for real-time clock
- C 115/230 V mains selection switch
- D Fuses
- E Terminal strips for outputs
- F Cable terminal screws
- G RS232 interface
- H Connections for sensors, digital inputs, interface and mA outputs
- I Display connection

The following sensors can be connected to the gas monitoring system GMS *plus*:

- 2x Chloratect sensors for chlorine, chlorine dioxide and ozone
- or 2x 4 – 20 mA sensors
- 2x Pt1000 temperature sensors



Please note

Either a Chloratect sensor or mA sensor can be connected per sensor channel.

*Chloratect sensors for
Chlorine, chlorine dioxide and
ozone*



4 – 20 mA sensors



Pt1000 temperature sensors

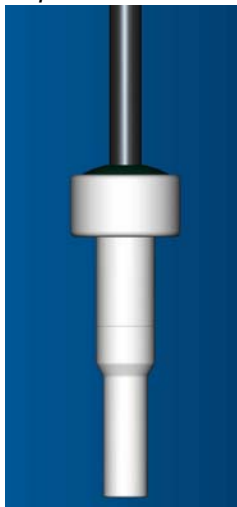

*Battery supply for
24 V gas monitoring system
GMS plus*

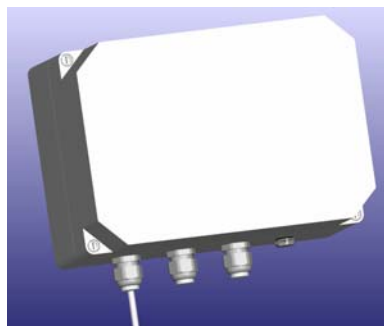

As an option, a battery supply (Part No. W3T158770) can be connected to the 24 V gas monitoring system GMS *plus*.

Lead battery
Power supply: 98 – 264 V AC

4. Functions

4.1 Application

The gas concentration and temperatures in rooms must be monitored when dosing, storing and producing gases.

In the event of gas escape, personnel are immediately warned by optical and acoustic signals.

Oxidizing gases such as chlorine (Cl_2), chlorine dioxide (ClO_2) and ozone (O_3) are used in water treatment. The proven Chloratect sensors are available to monitor these gases.

Third party sensors with passive 4 – 20 mA output can be used for other applications.

Pt1000 temperature sensors measure the room temperature.

The appropriate safety measures must be put in place when storing and dosing gases.

Oxidizing gases in the atmosphere endanger the health of operators and the operational safety of equipment.

Even low concentrations of these gases in the air are enough to reach the permissible limits for extended human contact.

Higher concentrations can cause damage to respiratory organs. Machines and equipment may also be damaged and result in costly repairs.

4.2 General

The gas monitoring system GMS *plus* continuously measures the concentration of gas and the temperature in rooms.

It is specifically designed for use in potable water and pool water treatment or for industrial use.

Typical applications:

- Chlorine gas room monitoring in swimming pools
- Ozone gas monitoring in potable water disinfection systems.

The GMS *plus* processes the signals from two gas sensors and up to two temperature sensors (Pt 1000) simultaneously.



Please note

The temperature measurements are not used for gas sensor temperature compensation.

Inputs are integrated for alarm acknowledgement as well as for door contact switches to switch off alarms. An internal buzzer signals active alarms.

The GMS *plus* sends an optical or acoustic warning signal as soon as a set limit value has been exceeded.



Attention!

The installed acoustic signal transmitter (beeper) can only be heard in the immediate vicinity of the GMS *plus*.

All alarms are indicated by an LED on the front membrane.

Sensors

The GMS *plus* is operated with:

- Chloratect sensors
- Passive mA sensors
- Temperature sensors I/II.

Sensor I room I
corresponds to

Sensor II room II
corresponds to

*Measuring ranges
Chloratect sensors*

0 – 5 ppm / 0 – 20 ppm for Cl₂ and ClO₂
0 – 1 ppm for O₃

<i>Measuring ranges passive mA sensors</i>	<p>The passive mA sensor measuring ranges are freely scalable between 0 – 1000.</p> <p>The sensor type and unit are variably definable.</p>
<i>mA outputs</i>	<p>The sensor channel I and II gas concentrations and the temperature I are output via analog outputs (4 – 20 mA).</p>
<i>Links</i>	<p>An RS485 interfaces is integrated to link to the Process Monitoring System and OPC server.</p> <p>As an option, a configured Wallace & Tiernan RS232 printer can be linked via the RS485 interface, if the printer distance is <15 m.</p>
<i>Safety functions</i>	<p>The following safety functions are integrated into the control if configured accordingly:</p> <ul style="list-style-type: none">• Access code protection (level 1).• Maximum value and average value over the past 8 hours are displayed.• Each sensor channel has two isolated alarm outputs with adjustable switching threshold, delay and alarm mode (latched, unlatched, etc.).• For example, alarm 1 can be used as the preliminary alarm and alarm 2 as the main alarm. Each alarm is assigned a relay.• A min and max limit value can be set for each temperature measurement.• The installed sensor alarm activates if there is an error on the sensor (short circuit, line break, etc.).• The sensor alarm is assigned a relay (K8). You may select which sensor alarm can trigger the sensors (Sensor I, Sensor II, Temp I, Temp II).• Three variably definable common alarms can be configured. Multiple assignments are possible, for example: Alarm 1/2 of sensor I Alarm 1/2 of sensor II Power failure Battery error Temperature I Min/Max Temperature II Min/Max
<i>Test function</i>	<p>The integrated test function simulates a sensor current that corresponds to the measuring range end value. It can be used to test the measured value display as well as the set alarms.</p>

4.3 Alarms

The alarms are output via relay contacts and red LED.

*Alarm settings
sensor channel I and II*

Each sensor channel has one alarm 1 and alarm 2, which can each be assigned different switching thresholds within the measuring range.

You can set a delay time of 0 – 120 min for each alarm.

Each alarm can be defined as:

- N.O. contact (normal status = opened)
- N.C. contact (normal status = closed)
- unlatched
- latched with confirmation

See 4.3.1 "Alarm modes" on page 26.

Door contact input

A door contact input is integrated for each sensor channel. For example, to switch off the sprinkler system when the gas room doors are opened (see 4.5 "Door contact switch" on page 32). When a door contact switch is used, local safety regulations must be observed.

Sensor alarm

The sensor alarm is designed as a common alarm. The sensor inputs can be freely assigned.

Multiple assignment is possible on:

- Sensor I
- Sensor II
- Temperature I
- Temperature II

If the defined sensor input signals are exceeded in either direction (wire break, sensor error, etc.), the sensor alarm is activated if this sensor is assigned to the sensor alarm.

You can select an ON delay of 0 – 5 min.

For Chloratect sensor, μA signal $< 0.1 \mu\text{A}$.

For mA-Sensor, mA signal $< 4 \text{ mA}$.

The sensor alarm can be defined as:

- N.O. contact (normal status = opened)
- N.C. contact (normal status = closed)
- unlatched
- latched with confirmation
- latched with reset

See 4.3.1 "Alarm modes" on page 26.

Common alarm

The common alarms are variably definable. The causes can be freely and multiply selected.

Different alarm modes can be defined for each common alarm:

- N.O.contact (normal status = opened)
- N.C.contact (normal status = closed)
- unlatched
- latched with confirmation
- latched with reset

See 4.3.1 "Alarm modes" on page 26.

The common alarm activates as soon as **one** of the selected causes is activated.

Common alarm 1 and 2

The following can be defined for common alarm 1 and 2:

- Alarm 1 and 2 of sensor I
- Alarm 1 and 2 of sensor II
- Temperature I Min + Max
- Temperature II Min + Max
- Sensor alarm

Common alarm 3

The following can be defined for common alarm 3:

- Battery supply power failure
- Error
- Battery empty
- Battery error
- Temperature I Min + Max
- Temperature II Min + Max

Temperature alarm

The GMS *plus* allows you to define a min and max alarm value for each temperature measurement.

An ON delay of 0 – 120 min can be defined for each temperature alarm.

You can realize a relay function for the temperature alarms with common alarm 1 – 3.

As follows: Set common alarm 1 – 3 assignment to Temp 1 Min, Max or Temp II Min, Max.

4.3.1 Alarm modes

The alarms can be configured as described above.

Unlatched alarm without acknowledgement option (N.O. unlatched, N.C. unlatched)

The LED lights up in the event of an alarm and goes out automatically when the alarm conditions are eliminated. The same applies to the relay contact.

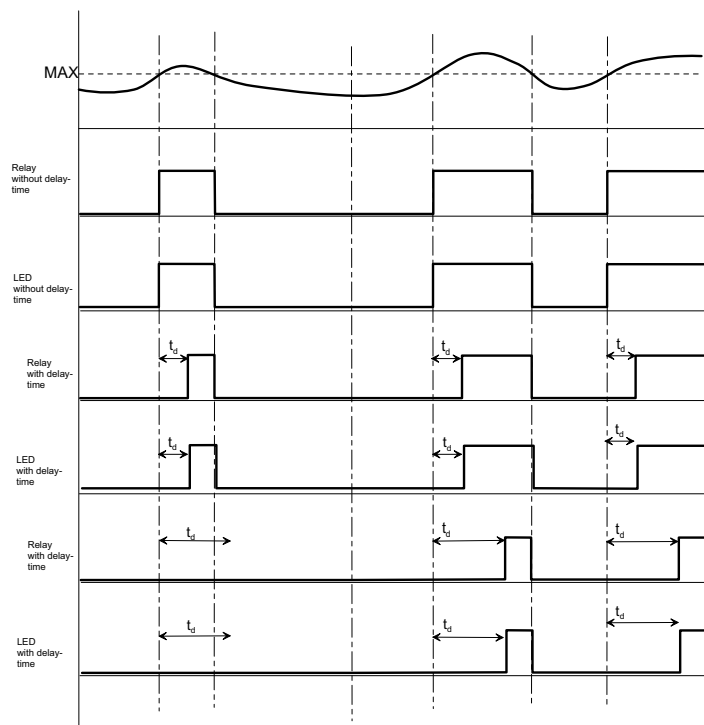

Latched alarm with reset acknowledgement option (N.O.latched, N.C.latched)

The LED flashes in the event of an alarm until the alarm is acknowledged. The LED goes out upon acknowledgement and the associated relay is released even if the set alarm conditions are still present when the alarm is acknowledged.

The relay is released upon acknowledgement.

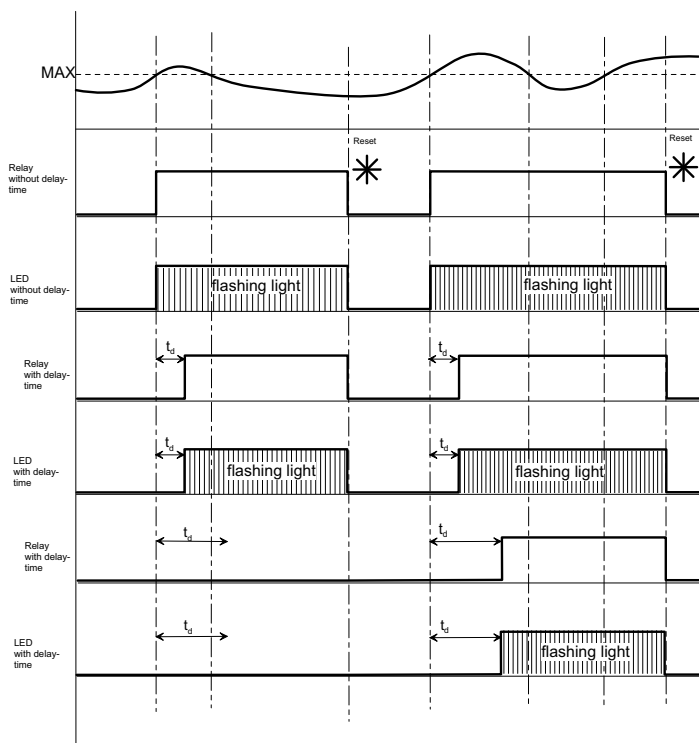

Attention!

A pending alarm can always be deleted when selecting this function. If this is the case, signaling by the still pending alarm seizes!

*Latched alarm
with acknowledgement
(acknowledgement option)
(N.O. latched ack)
N.C. latched ack)*

The LED flashes in the event of an alarm until the alarm is acknowledged.

If the alarm condition is no longer present when the alarm is acknowledged, the LED goes out.

If the alarm condition is still present when the alarm is acknowledged, the LED resets from flashing to permanent illumination. The LED lights up until the alarm condition is eliminated (auto-reset).

The relay is released upon acknowledgement, but only if the cause was eliminated.

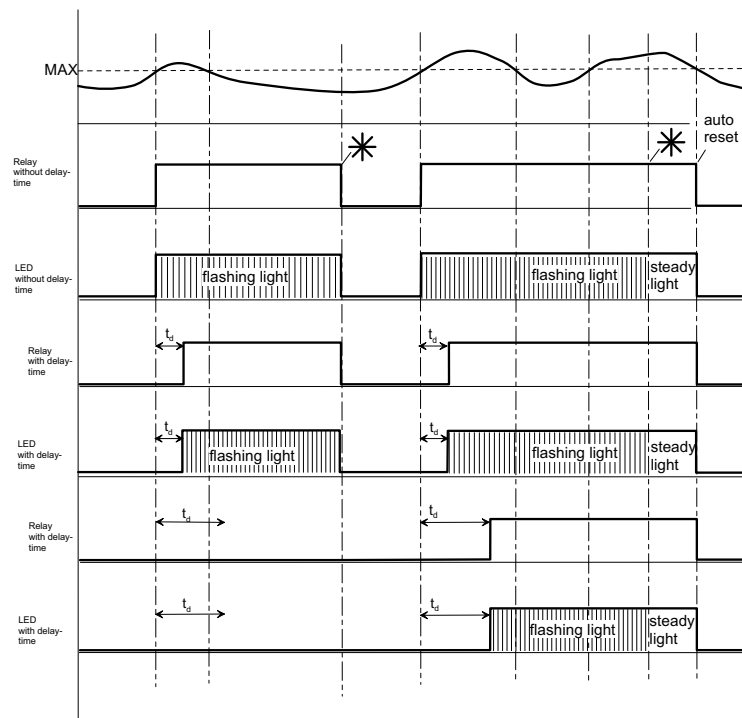

*Internal signal transmitter
(beeper)*

In the menu "Setup" - "Beeper" , there is an option to activate an internal beeper if an alarm occurs.

When this is activated, it can be assigned to :

- Common alarm
- Sensor alarm
- Alarm I 1/2 and/or Alarm II 1/2
(Multiple assignment possible)

The internal beeper alerts as soon as the selected alarm is activated.

The beeper switches off when the cause of the alarm has been eliminated or a latched alarm is canceled via the star key or external acknowledgement key.



Please note

The internal signal transmitter (beeper) can only be heard in the immediate vicinity of the GMS *plus*!

4.4 Interfaces

An RS232/RS485 interface is available to connect an external printer or RS485 bus connection. Only one mode is possible: either a printer protocol or RS485 bus connection.

RS232 The RS232 interface is used to connect a printer.

Specification of the RS232 interface for printer operation:

- Data transfer 9600 baud
- Parity straight
- Length of word 8 bit

A log is printed for each day (see below).

The daily log consists of a log header, trend graphs and the output of the daily min. and max. values.

The supplied measurements and the corresponding parameters such as the alarm value, alarm delay and common alarm configuration are printed in the log header.

Then the trend graphs are printed including the measuring range as well as the current measured values and the average values every half hour as numeric values. The trend graphs are recorded at one-minute intervals.

Printer log

```

-----
Gas Monitor System (GMSplus) / WALLACE & TIERNAN / V: 1.00                               18.07.06
-----
parameter-setup
-----
no.: type: meas. range: unit: alarm          alarm delay          : common alarm          sensor fault
      1:      1:      2:      1:      2:      1:      2:      3:
I  C12  0.0 - 5.0  ppm  0.5  4.0  0.0 min.  1.0 min.  : - - - -
I  Temp 0.0 - 50.0 °C  15  35  ----  ----  :
II C12  0.0 - 5.0  ppm  2.5  4.0  1.0 min.  1.0 min.  :
II Temp 0.0 - 50.0 °C  15  35  ----  ----  :

      (I)      (II)      (I) C12      (II) C12
      0.0      0.0      °C      ---      50.0 0.0      °C      ---      50.0
time: act.: avg.: act.: avg.: 0.0      ppm      ---      5.0 0.0      ppm      ---      5.0
00:00 0.5  0.5  0.8  0.0
00:30 0.5  0.5  0.8  0.1
01:00 0.5  0.5  0.8  0.2
01:30 0.5  0.5  0.8  0.3

```

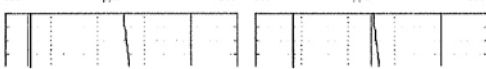



Please note

The maximum cable length between the interface and the printer must not exceed 15 m.

Available for log printout: RS232 log printer, printer connecting cable 3 m and 15 m; the printer includes setup instructions.

See 8. "Accessories and spare parts" on page 101.

RS485 bus connection

The RS485 interface provides connectivity to:

- The Wallace & Tiernan Process Monitoring System, which is a web-technology-based visualization system for connection to Wallace & Tiernan measuring, control and process systems.
- Higher level visualization systems through OPC Server Data Access V2.0.
- A Wallace & Tiernan RS485 log printer already available (e. g. from a previous system) may be used.

The GMS *plus* RS485 interface is potentially isolated. To integrate into a Wallace & Tiernan bus system, two terminal strips, a terminating resistor R_t and balancing resistor R_u and R_d are integrated into the GMS *plus*.

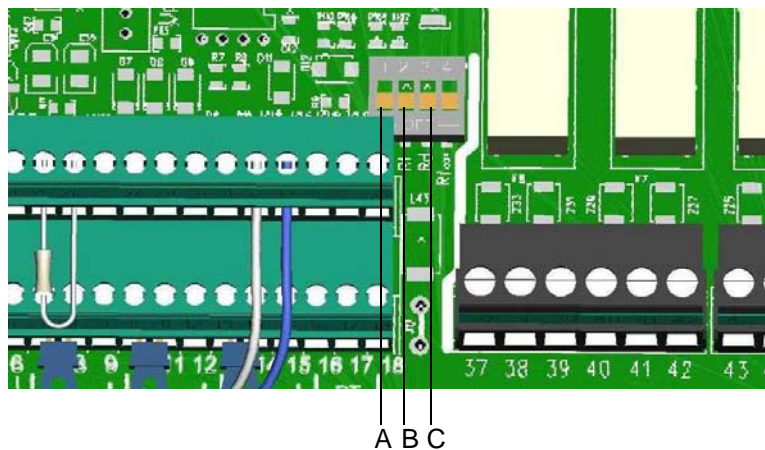

- A *R_u-balancing resistor*
 B *R_t-terminating resistor*
 C *R_d-balancing resistor*



Please note

The instruction manual of RS485 interface can be requested from your contractual partner or can be downloaded from the homepage www.evoqua.com.

4.5 Door contact switch



Please note

This function is not applicable to DGUV 107-001!
Observe local safety and installation regulations!

Each sensor channel has a digital input (DI1/DI2) to connect a door contact switch.

The associated sensor channel's alarm contacts are switched off when doors are opened. The LED begins to flash rapidly.

Application example

Sprinklers off when the doors are opened.
The alarm contacts switch back on once the doors are closed and the alarm is still active.

The alarm LED switches the current alarm status (flashing or continuous). If the cause of the alarm has been eliminated and latched alarms cleared, the LED goes out and the alarm contact is released.

The door contact switch is designed to be fail safe and must therefore be connected as the make contact (doors closed = open contact).



Please note

The door contact function is switched off by default. The function can be switched on under "Sensor I" and "Sensor II" in the menu "door contact".

An N.O.Contact must be used as the door contact (contact is open when door is closed).

4.6 Temperature measurement (Pt1000 sensor)

The temperature measurement sensor monitors the room temperature.

One temperature input is available for each sensor channel.

The temperature sensors can be adjusted in the calibration menu if deviations from a comparative measurement are present (in menu "Calibration I").

Each temperature sensor can be assigned the following separately:

- min and max limit value
- alarm delay

The min and max limits can be assigned to a common alarm.

The temperature measurements are used to monitor the room temperature for sensor I and II.



Please note

The temperature measurements are not used for gas sensor temperature compensation.

4.7 mA outputs

The GMS *plus* has three mA outputs with 4 – 20 mA output signal to connect a line recorder, an mA remote display or another additional processing system.

Sensor outputs:

- mA output 1 is for sensor I
- mA output 2 is for sensor II
- mA output 3 is for temperature measurement I.

A universal load monitor reports, for example, open mA loops and excessive loads (max. 600 Ohm).

The range 4 – 20 mA is a fixed range.

It corresponds, for example, to a measuring range of:

0 ppm Cl₂ : 4 mA

5 ppm Cl₂ : 20 mA

4.8 Power fail output

A power fail output can be configured with the common alarm 1, 2 or 3.

Power supply

If power is supplied to the GMS *plus*, the common alarm activates (e. g. common alarm 1 = K5).

Power failure

A power failure automatically releases K5 and reports an error.

The common alarm output must be set as follows:

Example of common alarm 1

Common alarm 1 => do not set assignment
Common al. mode 1 => Set "N.C. unlatched"

4.9 Test function



Please note

Available for Chloratec and mA sensors!

The set alarms and the measured value display are tested with the test function.

Activating test

- 1 Select menu "CALIBRATION".
 - 2 Set parameters "Test Sensor I" and "Test Sensor II" to "On".
 - 3 The unit will simulate a sensor signal for five minutes. This corresponds to the measuring range end value.
 - 4 The measuring range now displays the range end value.
-



Please note

The set alarms must be active after the set delay period!

The GMS *plus* switches the test signal back off after the signal test has run for five minutes.

Switching off test

- 1 Select menu "CALIBRATION".
 - 2 Set parameters "Test Sensor I" and "Test Sensor II" to "Off".
 - 3 The test is complete.
-



Attention!

The safety systems (e.g. sprinkler) must be deactivated before conducting a test to avoid damages. Alarm forwarding to other institutions (e. g. integrated control centers, fire department, etc.) must also be deactivated to avoid false alarms.

4.10 Battery supply (optional)

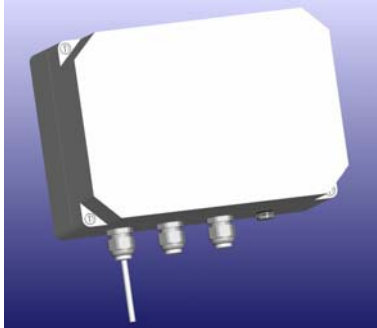

The GMS *plus* comes optionally with a 24 V battery supply. This is only available together with a 24 V gas monitoring system GMS *plus*.

The battery supply is connected to the GMS *plus* with a pre-wired plug connector.

An 8-pin socket is installed on the GMS *plus*. A 1.5 m long connection cable with 8-pin plug is attached to the battery module. This connection cable is plugged into the GMS *plus*.



Please note

A protective ground connection must be made separately on the GMS *plus*.

The battery supply switches from the mains to the battery without interruption.



Please note

A charged battery will bridge a power failure of at least 10 hours.

The operating duration is less with additionally connected consumer units!

The GMS *plus* is fully operational during this time.

The batteries are charged automatically and by temperature during mains operation.

Battery supply voltage

During commissioning the GMS *plus* is not supplied with 24 V from the battery supply before power has been applied to the battery supply.



Please note

The connecting plug to the battery module must be removed in advance of repair on or replacement of the GMS PCB to ensure it does not carry any voltage.

*Battery replacement
if error message received*

The battery must be replaced if the error message "battery ?" is displayed. See 7.3 "Replacing a fuse or battery" on page 97.

This message also appears if the ambient temperature around the battery is greater than 45 °C. The battery must not be replaced in this case. However, the ambient temperature around the battery must be reduced, otherwise the battery life may be reduced.

Battery life

To achieve satisfactory battery life, the battery temperature should not exceed 20 °C for sustained periods of time. Higher temperatures shorten battery life.



Please note

To guarantee battery power when needed, the batteries must be replaced every 3 years.
Higher room temperatures (20 °C) require more frequent battery replacements.

*Switching off power supply
for longer periods*

If the GMS *plus* will not be used for prolonged periods and the power supply switched off, the battery module must be unplugged. This way the battery will not be discharged, thereby extending the battery life.

5. Installation

5.1 Transport and storage

- Transport* The unit is supplied in standard packaging. During transport, the packaged unit must be handled carefully and should not be exposed to wet weather or moisture.
- Check that the transport packaging is undamaged.
- In the event of damage, please inform the transport company immediately, as your rights to compensation will otherwise be lost.
- If the device is damaged, please contact the respective contractual partner immediately.
- Keep the packaging until the unit has been correctly installed and taken into operation.
- Storage* Store the unit and the sensors in a dry place that is not exposed to the weather. Storage temperature, see "Technical data" on page 11.

5.2 Installing the gas monitoring system GMS *plus*



Attention!

All electrical work on the unit may only be performed by qualified electricians.

Modifications to the unit which go beyond those described in this manual are not permissible.

Carry out the work in the described sequence!

Requirements on the environment

The unit must be protected against rain, frost and direct sunlight and may therefore not be installed outdoors.

It must be mounted horizontally on a flat wall in a frost-free room with an ambient temperature of 0 to 50 °C.

The air in the room should be non-condensing.

Unpacking

Pay attention to small parts during unpacking!

Checking the mains voltage

The mains voltage of the gas monitoring system GMS *plus* is configured to customer specifications in the factory (230 V, 115 V or 24 V).



Please note

Check the mains voltage after unpacking the unit.

The mains voltage is indicated on the type plate (upper left side of the unit).

**GMS *plus* installation
with mounting rail**

- 1 Fasten the mounting rail to the wall with two screws (diameter 5 mm) and two dowels (diameter 8 mm).
- 2 Hook the GMS *plus* onto the mounting rail so that it is flush at the right and fasten to the wall with a screw (diameter 5 mm) and a dowel (diameter 8 mm).

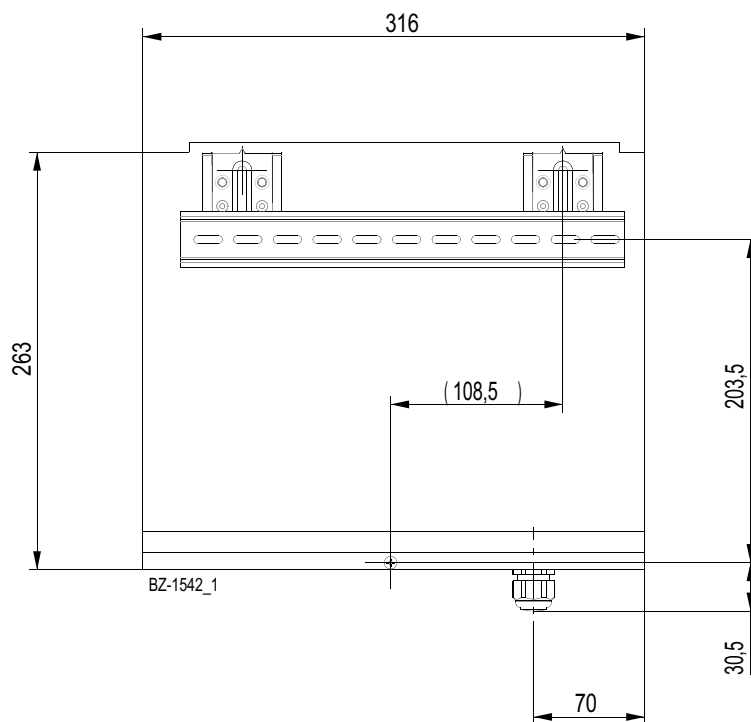

*GMS plus installation
without mounting rail*

- 1 Hook the GMS plus unit onto suitable tallow-drop screws with the top holding fixtures.

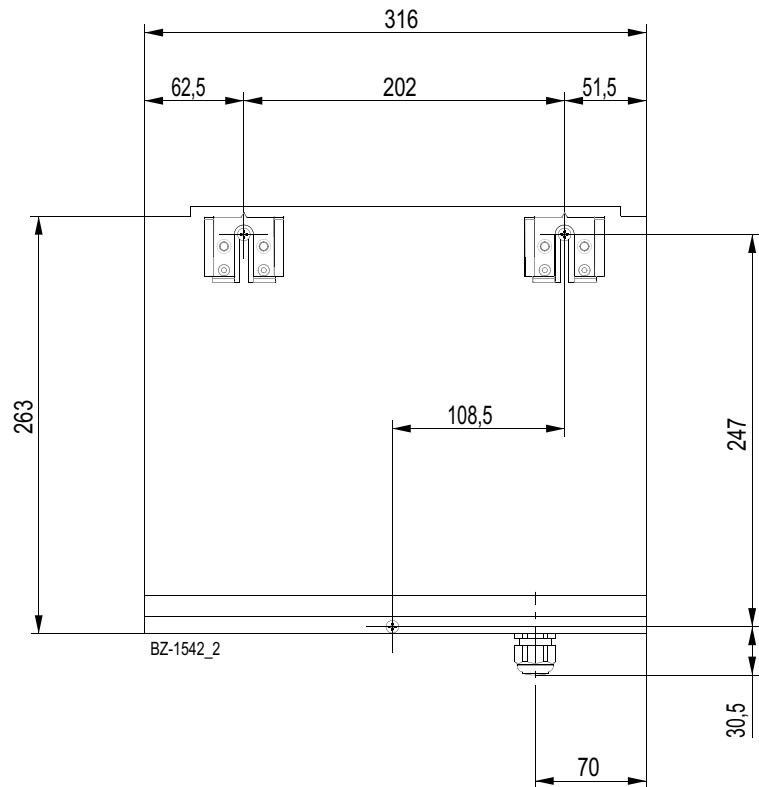

5.2.1 Installing sensors

Requirements on the environment

The following must be observed when installing the sensors:

- A site for the sensor must be selected to enable the sensor to come into contact with the air gas mixture it is to monitor.
- Install the sensor approx. 35 cm above ground level.



Please note

Gases such as chlorine (Cl₂), chlorine dioxide (ClO₂) and ozone (O₃) are heavier than air and therefore concentrate near the floor.

Please consult the sensor's operating manual if dealing with other gases.

- Do not install the sensor right beside a heat source (e. g. radiator, ventilator, etc.).
- Pay attention to the ambient conditions. The temperature, humidity, etc. must remain constant.



Please note

Avoid sudden changes in temperature (< 5 C/h).

Sensor holder Chloratect

1 Fasten the sensor holder to the wall with the supplied screws and

2 then clamp the sensor into the holder.

Sensor cover Chloratect

3 Place the sensor cover on the sensor.



Please note

This protects the sensor from drafts and spray.

Gas monitoring system GMS plus

4 Install gas monitoring system GMS *plus* in a separate, gas-free room.

Connecting cable

5 Install the connecting cable between GMS *plus* and the sensor.



Please note

The connecting cable comes in standard lengths of 2 m and 10 m. The cable may be extended up to 100 m upon request.

For cable extensions, make sure that the sensor line polarity is not reversed!

Terminal box

6 If necessary, install a terminal box above the sensor.

*Please note*

The terminal box must be splash-proof.

7 Lay a two-core shielded cable from the terminal box to the GMS *plus*.

5.2.2 Installing battery supply (optional)

Requirements on the environment

The following must be observed when installing the battery supply:

- The battery supply must be protected against rain, frost and direct sunlight and may not be installed outdoors.
- Install the battery supply right beside the GMS *plus*.
- It must be mounted horizontally on a wall in a frost-free room with an ambient temperature of 0 – 45 °C. Cable terminal screws down.
- The air in the room should be non-condensing.

*Please note*

The battery supply voltage is designed for 98 – 265 V AC (47 – 63 Hz).

The output voltage is 24 V DC. Only applicable with a 24 V gas monitoring system GMS *plus*.

Proceed as follows:

- 1** First electrically install the GMS *plus*.
- 2** Then plug the connecting cable into the GMS *plus*.

*Please note*

The connecting cable to the GMS *plus* is 1.5 m and may not be extended.

Battery supply voltage

The GMS *plus* is initially supplied with 24 V from the battery supply during commissioning if power has been applied to the battery supply.

*Please note*

The connecting plug to the battery module must be removed in advance of repair on or replacement of the GMS PCB to ensure it does not carry any voltage.

5.2.3 Electrical installation

See 9. "Wiring diagrams" on page 103.



Warning!

Risk involving electric current.

Only authorized and qualified electricians are permitted to install the unit and open the housing. The unit may only be taken into operation when the housing is closed, and must be connected to protective earth. Modifications to the unit that go beyond those described in this manual are not permissible.

Comply with local regulations when installing the unit (e. g. GUV).



Warning!

The unit is not equipped with a mains switch and is in operation as soon as the supply voltage is applied. An external switch or circuit breaker is therefore necessary.

Provide a mains fuse locally (6 A). The conductor cross section of the mains cable must be at least 0.75 mm (AWG 18).

When connecting system components (e.g. devices, motors, pumps) as well as when entering operating data, the system components must be switched off in order to prevent uncontrolled activation or any incorrect function.



Attention!

To ensure safe and correct commissioning, knowledge of the operation, connected electrical load, measurement signals, cable assignment and fuse protection of the connected devices and machines and the relevant safety regulations is required.

Commissioning of the unit may therefore only be performed by qualified and authorized electricians.

Incorrectly connected devices can be damaged, possibly irreparably, or cause faults in other equipment when they are switched on or in operation. Ensure that the measuring and control cables are not mixed up or are able to make contact with one another. Never connect or disconnect any cables to which voltage is applied!

Opening the housing

- 1 Remove the housing cover of the GMS *plus* unit by pressing gently on the two release buttons at the top of the housing.
- 2 Unscrew the six screws on the housing cover of the GMS *plus* unit.

*Attention!*

The indicators and operator controls on the cover of the GMS *plus* unit are connected to the housing by wires.

- 3 Carefully remove the housing cover of the GMS *plus* unit, making sure that the cover is not connected to the ribbon cable, unplugging the ribbon cable if necessary.

Connecting the gas monitoring system GMS plus

Connect the GMS *plus* to the following:

- A separate and autonomous power supply (e. g. 24 V battery supply, see 5.2.4 “Electrically install battery supply (optional)” on page 46) or
- In the case of mains supply, a separate fuse protection through which only the GMS *plus* will be supplied.

Connect system components to the GMS *plus* according to the wiring diagrams.

- 1 Connect sensor cable, switch, valves and printer line to the terminals in the bottom section of the housing.
- 2 Protect the mains supply and/or battery supply of the gas monitoring system GMS *plus* externally by fuse (max. 6 A).

5.2.4 Electrically install battery supply (optional)

A battery supply is available as an option for the 24 V GMS *plus*.

Power is switched from the mains to the battery without interruption.

*Please note*

A power failure of at least 10 hours can be bridged with a charged battery.
This ensures that the GMS *plus* will continue to function.

Charging the battery

The battery is automatically charged during mains operation. The charging current is limited so that the battery can remain continuously connected.
The battery supply is connected to the GMS *plus* with an 8-pin connector cable combination (length: 1.5 m).

*Please note*

See 9. “Wiring diagrams” on page 103.

*Connecting the connection
cable*



Warning!

Short circuits and damage on the GMS *plus*!

Plug the battery supply to the GMS *plus* only after all system components have been installed.

Otherwise, short circuits and damage to the unit may occur as a result of accidental contact with the connection wires when connecting in the GMS *plus* .



Please note

First disconnect the plug connectors from the battery before repairing or replacing the gas monitoring system PCB!

*Switching off the GMS plus for
longer periods*

If the GMS *plus* gas detection device is not needed for a longer period, switch off the mains power supply and unplug the plug connector to the battery supply.



Attention!

The battery must be unplugged to prevent unnecessary discharging.

5.3 Commissioning the Chloratec sensor

Filling electrolyte

Before connecting the GMS *plus*:

Fill the sensor with electrolyte approx. 1 to 2 hours. In order to ensure that the sensor's wick is penetrated with moisture (at ambient temperatures).



Please note

Do not hold the sensor upside down!

Do not additionally moisten the sensor wick!



Installing the chlorine, chlorine dioxide and ozone sensors:

- 1 Remove the transparent sensor reservoir from the upper, grey sensor housing.
- 2 Fill with electrolyte to the upper mark (MAX, approx. 2.5 cm high).
- 3 Lightly moisten the sensor housing's o-ring with electrolyte solution.
- 4 Slide the reservoir over the o-ring.

Setting the GMS plus-Chloratec input

Proceed as follows:

- 1 Go to the menu "SENSOR I" - "Sensor input I" and select "Chloratec".
- 2 In the menu "Sensor type I" , enter "Cl₂", "ClO₂" or "O₃" as the sensor type.
- 3 In the menu "Sensor unit I" , set the unit as "ppm" or "ml/m³".
- 4 Select the measuring range (for Cl₂, ClO₂ only) "5 ppm" or "20 ppm".



Please note

Setting sensor channel II:

Follow the same procedure as sensor channel I but in the menu "SENSOR II".

Setting the zero point current

Proceed as follows:

- 1 Open the GMS plus housing.
- 2 At Chloratect input I (terminal 21/22) or Chloratect input II (terminal 25/26), install the 1 MOhm resistor.



Please note

In the GMS plus, the 1 MOhm resistor is factory installed.

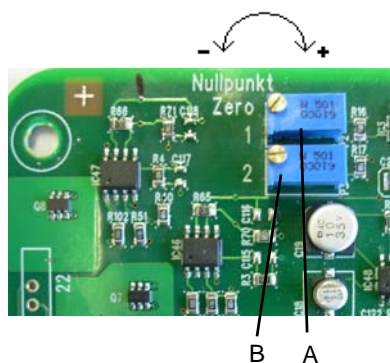

A Zero point potentiometer sensor I
B Zero point potentiometer sensor II

- 3 Select the menu "DIAGNOSIS" - "Input I" to display the cell current.
- 4 Using the potentiometer "Zero point 1", set the following cell current (upper left corner of the GMS plus-PCB):

Chlorine	1.2µA
Chlorine Dioxide	1.2µA
Ozone	0.4µA



Please note

Setting sensor channel II:

Follow the same procedure as with sensor channel I but select the menu "DIAGNOSIS" - "Input 2" and set the appropriate cell current with the potentiometer "Zero point 2".

- 5 Unclamp resistor and put in a safe place.
(e.g. attach to the housing with adhesive tape)



Please note

These resistors are needed when replacing the sensors and restarting the system.

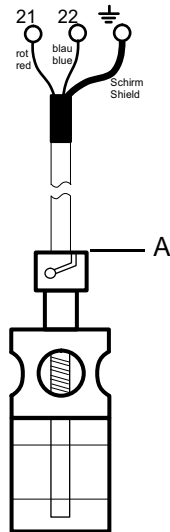
Connecting Chloratect sensor

A BNC plug

- 1 Clamp the Chloratect sensor cable (2 m or 10 m) to terminal 21 (red) and 22 (blue).
Channel II => terminal 25 (red) and terminal 26 (blue).
- 2 Connect BNC plug with Chloratect sensor.
- 3 During the run-in time (8 – 12 hours) the sensor adapts to the environmental conditions.
- 4 Subsequently check the zero point current and readjust if necessary.

5.4 Adjusting the span with comparative measurement and function test

*Please note*

If the accuracy must be greater than $\pm 15\%$, the span must also be set using a comparative measurement. See "Setting the span to factory setting" on page 51.

Before adjusting the zero point and the span, the sensor must be run in for approx. 8 to 12 hours.

The zero point must be adjusted for each Chloratect measurement input.

*Attention!*

False alarm!

Deactivate all alarms before setting the span or conducting the function test in order to prevent false alarms!

Reactivate the alarms only after the displayed value falls below the alarm limit!

5.4.1 Chlorine sensor

Adjusting the zero point



Please note

During the zero point adjustment there should be no chlorine, chlorine dioxide or ozone gas in the room air!

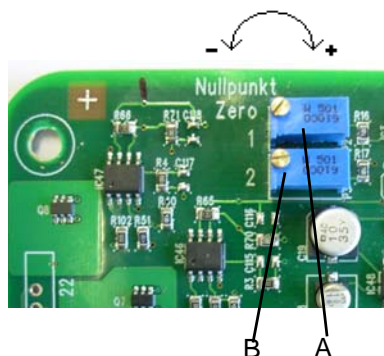

Proceed as follows:

- 1 Press the F key in the basic display until the menu "DIAGNOSIS" is shown.
- 2 Press the  key until the menu "Input I" or "Input" appears. The current sensor current is displayed.
- 3 Slowly adjust the zero point potentiometer 1 (for input I) or zero point potentiometer 2 (for input II) until "1.2 μ A" is displayed.

A Zero point potentiometer sensor I
B Zero point potentiometer sensor II







Please note

The potentiometers are located on the upper left part of the GMS *plus* PCB.

Setting the span

Proceed as follows:

Setting the span to factory setting

- 1 Press the F key in the basic display until the menu "CALIBRATION" is shown.
- 2 Press the  key until the menu "Test Sensor I" or "Test Sensor II" appears.
- 3 Use the  key to switch to edit mode.
- 4 Use the  key to select menu "Test" and press the  key to save.



Please note

The GMS *plus* simulates a cell current for 5 minutes according to the measuring range-end value.

- 5 In the menu "Span Sensor I" or "Span Sensor II", set the measuring range-end value to 5.0 ppm or 20 ppm and press the  key to save. To end the simulation, go to "Test Sensor" and select "Off".

Setting the span using a comparative measurement

Follow the same procedure as factory setting; instead of executing a test, the comparative measurement value is set.

Function test with chlorine gas generator



- 1 Start the chlorine gas generator (Part No. W3T159905).
Wait 30 minutes for the generator to run in.

Please note

Read operating instructions for the gas generator!

- 2 Place the sensor into the chlorine gas generator.
Once the display on the gas monitoring system GMS *plus* has stabilized, the displayed value (diaphragm value $\pm 50\%$) should be the same as the disc value inserted in the air inlet.
- 3 Switch off the chlorine gas generator.
- 4 Remove the sensor.

5.4.2 Chlorine dioxide sensor

Adjusting the zero point



Please note

During the zero point adjustment there should be no chlorine, chlorine dioxide or ozone gas in the room air!

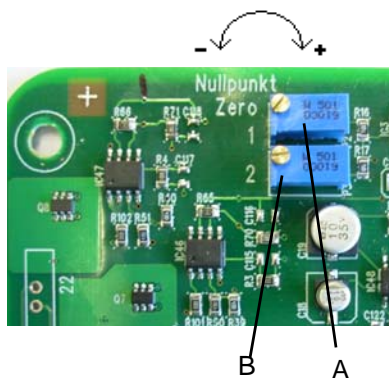

A Zero point potentiometer sensor I

B Zero point potentiometer sensor II

Proceed as follows:

- 1 Press the F key in the basic display.
The menu "DIAGNOSIS" is displayed.
- 2 Press the  key until the menu "Input I" or "Input II" appears.
The current sensor current is displayed.
- 3 Slowly adjust the zero point potentiometer 1 (for input I) or zero point potentiometer 2 (for input II) until "1.2 μ A" is displayed.







Please note

The potentiometers are located on the upper left part of the GMS *plus* PCB.

Setting the span

Setting the span to factory setting

Proceed as follows:

- 1 Press the F key in the basic display until the menu "CALIBRATION" is shown.
- 2 Press the  key until the menu "Test Sensor I" or "Test Sensor II" appears.
- 3 Use the  key to switch to edit mode.
- 4 Use the  key to select menu "Test" and press the  key to save.



Please note

The GMS *plus* simulates a cell current for 5 minutes according to the measuring range-end value.

- 5 In the menu "Span Sensor I" or "Span Sensor II", set the measuring range-end value to 5.0 ppm or 20 ppm and press the  key to save.
To end the simulation, go to "Test Sensor" and select "Off".

Setting the span using a comparative measurement

Follow the same procedure as factory setting; instead of executing a test, the comparative measurement value is set.

Function test with chlorine gas generator

Proceed as follows:

- 1 Start the chlorine gas generator (Part No. W3T159905).
Wait 30 minutes for the generator to run in.



Please note

Read operating instructions for the gas generator!

- 2 Place the 1 ppm chlorine disc into the air inlet of the gas generator.
- 3 Place the sensor into the chlorine gas generator.
Once the display on the gas monitoring system GMS *plus* has stabilized, the displayed value should be 1 ppm \pm 50 %.
- 4 Switch off the chlorine gas generator.
- 5 Remove the sensor.

5.4.3 Ozone sensor

Adjusting the zero point



Please note

During the zero point adjustment there should be no chlorine, chlorine dioxide or ozone gas in the room air!

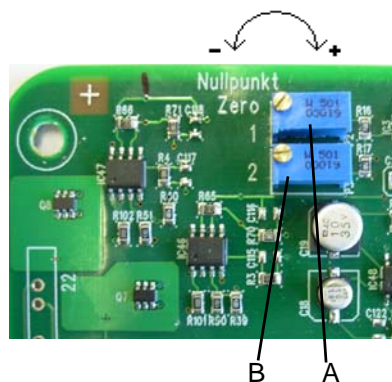

A Zero point potentiometer sensor I

B Zero point potentiometer sensor II

Proceed as follows:

- 1 Press the F key in the basic display.
The menu "DIAGNOSIS" is displayed.
- 2 Press the  key until the menu "Input I" or "Input II" appears.
The current sensor current is displayed.
- 3 Slowly adjust the zero point potentiometer 1 (for input I) or zero point potentiometer 2 (for input II) until "0.4 μ A" is displayed.







Please note

The potentiometers are located on the upper left part of the GMS *plus* PCB.

Setting the span

Setting the span to factory setting

Proceed as follows:

- 1 Press the F key in the basic display until the menu "CALIBRATION" is shown.
- 2 Press the  key until the menu "Test Sensor I" or "Test Sensor II" appears.
- 3 Use the  key to switch to edit mode.
- 4 Use the  key to select menu "Test" and press the  key to save.



Please note

The GMS *plus* simulates a cell current for 5 minutes according to the measuring range-end value.

- 5 In the menu "Span Sensor I" or "Span Sensor II", set the measuring range-end value to 1.0 ppm and press the  key to save.
To end the simulation, go to "Test Sensor" and select "Off".

Setting the span using a comparative measurement

Follow the same procedure as factory setting; instead of executing a test, the comparative measurement value is set.

Function test with ozone gas generator

Proceed as follows:

- 1 Start the ozone gas generator (Part No. W3T171363).
Wait 5 minutes for the generator to run in.



Please note

Read operating instructions for the gas generator!

- 2 Place the sensor into the ozone gas generator. Once the display on the gas monitoring system GMS *plus* has stabilized, the displayed value should be $0,4 \text{ ppm} \pm 25 \%$.
- 3 Switch off the ozone gas generator.
- 4 Remove the sensor.

5.5 Commissioning the mA sensor

Remove the protection cap



Please note

The sensor opening protection cap must be removed before commissioning the sensor!

Proceed as follows:

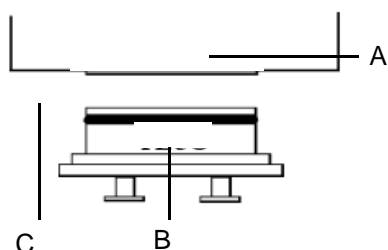

- A Sensor opening
- B Protection cap
- C Base

- 1 Remove the sensor opening protection cap.

Installing the mA sensor

- 2 Secure the sensor cable (2 m) or sensor cable (10 m) to terminal 19 (red) and 20 (blue).

Channel II => terminal 23 (red) and terminal 24 (blue).

- 3 Connect the BNC plug into the mA sensor.



Please note

During the run-in time the sensor adapts to the environmental conditions.

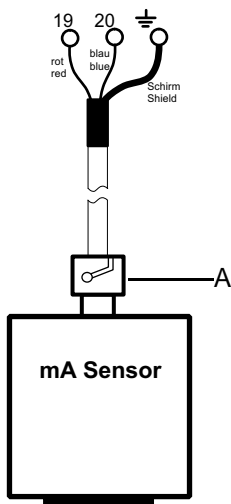

A BNC plug

- 4 In the menu "SENSOR I", parameter "Sensor input I", set the "mA Sensor".
- 5 In the menu "Sensor type I", set sensor types "CI2", "CIO2", "O3", etc. and/or select the variably definable sensor type "----".
You may define four characters for the variable sensor type.
- 6 In the menu "Sensor unit I", select the desired unit or variably definable unit "----".
You may define four characters for the variable unit.
- 7 Set the measuring range-initial value (see sensor data sheet).

8 Set the measuring range-end value.

End value	Display format
< 100	000.0
> 100	0000

9 Set factor (factory setting: 1.0)

This value must only be changed if the sensor's measuring range value is not defined identically to the gas monitoring system *GSMplus* measuring range.

Carrying out the function test

Before conducting a function test on the gas sensors, the following must be observed:

- All alarms must be deactivated.
- The operator must be informed that the alarms will only trigger for the test.
- The unit must be run for at least 24 hours so that the sensors and the electronics deliver stable measuring signals.
- The gas source output is connected to the gas sensor input.
- The generator gas concentration is set to the required concentration.
- The displayed sensor measured value must be about the same as the generator value (i.e. gas concentration in the gas cylinder).

*Please note*

Note the sensor response times!

- If the alarm settings were made, the response time function can be tested.

5.6 Commissioning



Warning!

Risk involving electric current.

Only authorized and qualified electricians are permitted to install the unit and open the housing. The unit may only be taken into operation when the housing is closed, and must be connected to protective earth. Modifications to the unit that go beyond those described in this manual are not permissible.

Commissioning procedure

The unit can be taken into operation after it has been installed.

The following table contains the individual commissioning steps in their correct sequence.

More detailed information is contained in the sections listed in the "Reference" column.

Completion of each task can be confirmed in the "Completed" column.



Please note

If this installation sequence cannot be complied with, please contact your contractual partner.

Settings overview using the example of a Chloratec sensor-

Seq.	Task	Reference	Completed
1	Connect electrical connections, check mains voltage and adjust if necessary.	5.2.3 - page 45 5.6.1 -page 65	<input type="checkbox"/>
2	Install and wire sensors. For Chloratec sensors, first commission the sensor!	5.2.1 - page 43 5.3 -page 48	<input type="checkbox"/>
3	For battery supply: Plug in the 8-pin connecting cable to the GMS <i>plus</i> .	5.2.4 -page 46	<input type="checkbox"/>
4	Switch on mains voltage.	5.6.1 -page 65	<input type="checkbox"/>
5	Select the language.	page 87	<input type="checkbox"/>
6	Set the time.	page 87	<input type="checkbox"/>
7	Set the date.	page 87	<input type="checkbox"/>
8	For battery supply: Set battery backup in the menu.	page 87	<input type="checkbox"/>
9	Set the internal signal transmitter (beeper) to the desired alarms.	page 87	<input type="checkbox"/>
10	Set the interface to the desired mode.	page 87	<input type="checkbox"/>
11	For bus operation: Set bus address.	page 87	<input type="checkbox"/>
12	Define access code (optional).	page 71	<input type="checkbox"/>
13	Set Sensor input I.	page 85	<input type="checkbox"/>
14	Set sensor type I.	page 85	<input type="checkbox"/>
15	Define sensor type (if variably definable).	page 85	<input type="checkbox"/>
16	Set sensor unit.	page 85	<input type="checkbox"/>
17	Define unit (if variably definable).	page 85	<input type="checkbox"/>
18	Select measuring range.	page 85	<input type="checkbox"/>
19	Possibly set factor I for mA sensor.	page 85	<input type="checkbox"/>
20	Set temperature input I.	page 85	<input type="checkbox"/>
21	Set sensor input II.	page 86	<input type="checkbox"/>
22	Set sensor type II.	page 86	<input type="checkbox"/>

Seq.	Task	Reference	Completed
23	Define sensor type II (if variably definable).	page 86	<input type="checkbox"/>
24	Set sensor unit II.	page 86	<input type="checkbox"/>
25	Define unit II (if variably definable).	page 86	<input type="checkbox"/>
26	Select measuring II range.	page 86	<input type="checkbox"/>
27	Possibly set factor II for mA sensor.	page 86	<input type="checkbox"/>
28	Set temperature input II.	page 86	<input type="checkbox"/>
29	Commission sensor.	page 48	<input type="checkbox"/>
30	Calibrate if necessary.	page 84	<input type="checkbox"/>
31	Set sensor alarm.	page 83	<input type="checkbox"/>
32	Set temperature alarm.	page 80	<input type="checkbox"/>
33	Set alarm sensor I.	page 78	<input type="checkbox"/>
34	Set alarm sensor II.	page 79	<input type="checkbox"/>
35	Set common alarm.	page 81	<input type="checkbox"/>
36	Carry out test function.	page 84	<input type="checkbox"/>

Setting overview - Features

GMS <i>plus</i>	Factory setting	Commissioning
ALARM SENSOR I		
Alarm value 1 I	2.5ppm	
Alarm delay 1 I	1.0min	
Alarm mode 1 I	N.O.n.sp.	
Alarm value 2 I	5.0ppm	
Alarm delay 2 I	1.0min	
Alarm mode 2 I	N.O.n.sp.	
Door contact	OFF	
ALARM SENSOR II		
Alarm value 1 II	2.5ppm	
Alarm delay 1 II	1.0min	
Alarm mode 1 II	N.O.n.sp.	
Alarm value 2 II	5.0ppm	
Alarm delay 2 II	1.0min	
Alarm mode 2 II	N.O.n.sp.	
Door contact	OFF	
TEMPERATURE		
Alarm value Min I	15°C	
Alarm value Max I	35°C	
Alarm delay I	10min	
Alarm value Min II	15°C	
Alarm value Max II	15°C	
Alarm delay II	10min	

GMS <i>plus</i>	Factory setting	Commissioning
COMMONALARM		
Common alarm 1	[]	
Common.AI.mode. 1	N.O.n.sp	
Common alarm 2	[]	
Common.AI.mode. 2	N.O.n.sp	
Common alarm 3	[]	
Common.AI.mode. 3	N.O.n.sp	
SENSOR ALARM		
Sensor al.assign	[]	
Sensor al.delay	1.0min	
Sensor.al.mode	N.O.n.sp.	
CALIBRATION		
Test Sensor I	Off	
Span Sensor I		
Test Sensor II	Off	
Span Sensor II		
Offs.Temp.Sens. I		
Offs.Temp.Sens. II		
SENSOR I		
Sensor input I	Chloratect	
Sensor type I	Cl2	
Type def I	----	
Sensor unit I	ppm	
Unit def. I	----	
Range Start I	0.0	
Measuring range/ Range end I	5.0	
Factor I	1.0	
Temperature I	OFF	

GMS <i>plus</i>	Factory setting	Commissioning
SENSOR II		
Sensor unit II	Chloratect	
Sensor type II	Cl2	
Type def II	----	
Sensor unit II	ppm	
Unit def. II	----	
Range Start II	0.0	
Measuring range/ Range end II	5.0	
Factor II	1.0	
Temperature II	OFF	
SETUP		
Language	German	
Battery supply	OFF	
Beeper	[]	
Interface	OFF	
RS485 busaddr	00	
Code def	000	

5.6.1 Set mains voltage



Warning!

Risk involving electric current.

Disconnect the power supply before opening the housing.
Only trained electricians are permitted to open the housing.



Warning!

Power error!

Do not operate this unit with incorrect voltage!

Unit fuse can blow.
Other damage or malfunctions may occur.

The set mains voltage must be checked before installation and
before connecting the connection cables.

Set mains voltage



Please note

Units with a 24 V connection cannot be adapted.

The switch to set the mains voltage and the fuse is inside the unit housing.

- 1 Open the housing by unscrewing the six housing screws.
 - 2 Remove cover and hold onto it.
-



Please note

Make sure not to stress the display cable.

- 3 If the ribbon cable to the display is unplugged, it must be plugged back in during reassembly.
-



Please note

Do not twist the cable.

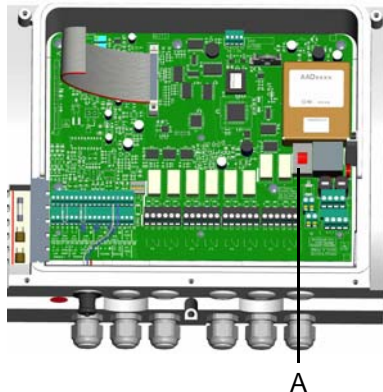

- 4 Set the mains voltage on the slide switch (A).
- 5 The mains voltage was changed.
Note the mains voltage set on the type plate (e.g. with water-resistant pen).

Example:

Mains voltage adjusted to 230 V!

Date – Name – Company – Department

Attaching the housing cover

Procedure:

- 1 Ensure that the cables are correctly inserted and that the plug connecting them to the display is firmly seated.
- 2 Carefully put the cover in place, ensuring that no wires are pinched or caught between the cover and the housing.
- 3 Attach the housing using the six screws.



Please note

Tighten the housing screws to a maximum torque of 0.7 Nm (± 0.15 Nm).

5.7 Shutdown

- 1 Switch off sprinkler system, empty if necessary.
- 2 Switch off operating voltage.
- 3 Unplug battery supply (optional).
- 4 Switch off printer (optional).
- 5 Protect measuring cell against frost, pour out electrolyte if necessary (rinse with water).

5.8 Change batteries (battery supply option)



Attention!

For safety reasons, the battery must be replaced after a battery error or no later than approx. 3 years.



Please note

New batteries can be ordered from Evoqua Water Technologies GmbH. Both batteries must be changed each time!

The battery supply is either with 2x 12 V/3 Ah or 4x 6 V/3 Ah equipped.

Proceed as follows:

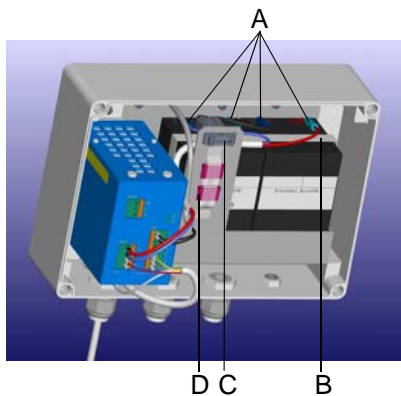

- 1 Loosen the four screws on the battery housing. Carefully remove the cover.
- 2 Remove the battery circuit fuse (C).
- 3 Remove the battery holding strap (B).
- 4 Remove the upper four plugs on the battery (A). See Picture 1 "Connection diagram with two batteries" or Picture 2 "Connection diagram with four batteries".
- 5 Remove and dispose of the batteries.



Attention!

Environmental hazard!

Do not throw away or burn the batteries!
Recycle the batteries (lead batteries).

The batteries must be disposed of in accordance with environmental protection regulations. To this purpose public or private waste disposal companies should be employed.

If such an organisation is not available or the products are not accepted, the product can be returned to Evoqua Water Technologies GmbH after prior consultation.

- 6 Insert new batteries.
The batteries must not be fastened down with the holding strap for stationary operation.

- 7 Connect the upper four plugs to the battery (A):
RED: +, Blue -
See Picture 1 "Connection diagram with two batteries" or
Picture 2 "Connection diagram with four batteries".
- 8 Plug the battery circuit fuse (C) back in.
- 9 Screw cover back on.



Please note

The new batteries are not fully charged after installation. The batteries can only bridge a power failure for 10 hours when they are fully charged (i.e. after 24 hours of mains operation).

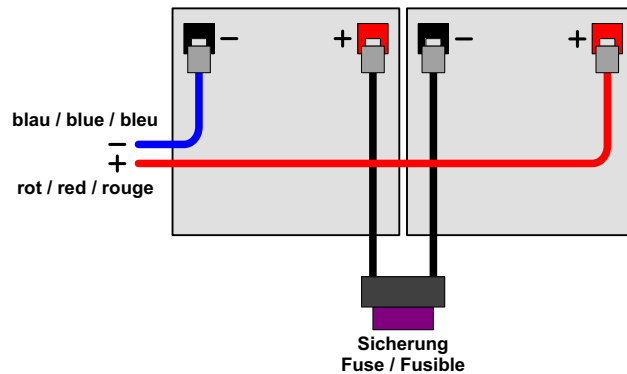

Picture 1 Connection diagram with two batteries

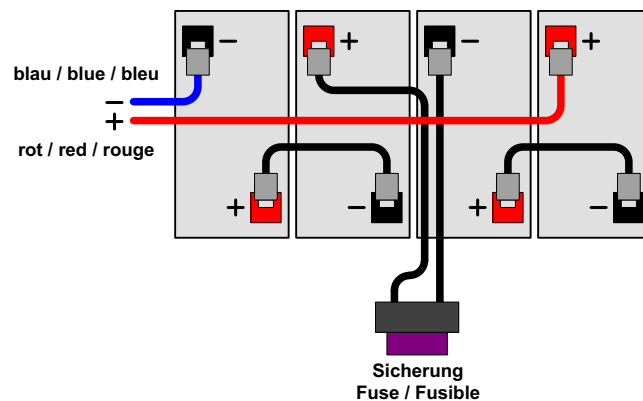

Picture 2 Connection diagram with four batteries

6. Operation

6.1 Display and operating elements

Gas monitoring system
GMS *plus*



- A Cover
- B Green LED (power)
- C Alarm message sensor I
- D Alarm message sensor II
- E Common alarms
- F Sensor error
- G Operator controls (keys)
- H LCD display

Key functions

Operating panel

**Up**

- Move up one level.
- Display the previous option.
- Increase value.

**Down**

- Move down one level.
- Display the next option.
- Decrease value.

**Star**

- Clear latched alarms, clear internal signal transmitter (beeper).

**Function**

- Display next menu (jump from main menu to main menu).

**ESCAPE (cancel)**

- Cancel input without saving new value.
- Return to main menu.
- Press the key again to return to the basic display.

**ENTER (input)**

- Switch to edit mode (">" is displayed before the value).
- Save new setting.

6.2 Notes on operation

During operation observe the following points:

- Check your entries and changes before you leave the menu.
- Use only your fingers to press the keys.
Do not press keys with hard or pointed objects, otherwise you may damage the sealed keypad (e. g. pencil).
- Protect menus with an access code.

Access code



Please note

An access code can be entered to protect against unauthorized or inadvertent incorrect operation.

The default code is "CODE def = 0", which means that an access code is not defined.

Defining access codes

Proceed as follows:

- 1 In the SETUP menu under "Code def.", enter the new access code (number between 1 and 999).
- 2 Press the  key to confirm.



Please note

The access code is automatically saved after 1 hour if the key is not pressed again.

Blocking with access code

To immediately block the unit using the access code, the code must be set and saved as a number in the main menu (not "Code def.").

Values may still be viewed without the access code, however they cannot be edited.

"Code ???" appears in the menu if an unauthorized access is attempted. The previous settings are redisplayed.

Values in the protected menus can only be edited if the correct access code is set in the main menu.

Removing access code

To unblock the gas monitoring system GMS *plus* from access code entry, Proceed as follows:

- 1 In the SETUP menu under "Code def." enter the number "000" and save.

*Please note*

Changes may be made without entering an access code.
The access code query is not displayed in the main menu.

Did you forget the access code?

The GMS *plus* must be reset to factory settings.



*Please note*

Attention:
All personal settings will be deleted.
Sensor calibrations will be deleted.

We recommend viewing all settings and making a note of them in a settings overview! See "Settings overview using the example of a Chloratect sensor-" on page 60.

Resetting default values

Proceed as follows:



- 1 Select "RESET" in the menu "DIAGNOSIS".
- 2 Press the  key to confirm.
- 3 Then press the  key until "***INIT***" is displayed.
- 4 The unit executes a RESET.
- 5 The unit sets the access code to "0" .
- 6 The factory settings are reset, and all personal settings and calibrations are deleted.
- 7 All settings and sensor calibrations must be made.

*No "***INIT***" display*

A normal RESET has been executed if "***INIT***" is not displayed.





Repeat process "Resetting default values".

Menu navigation

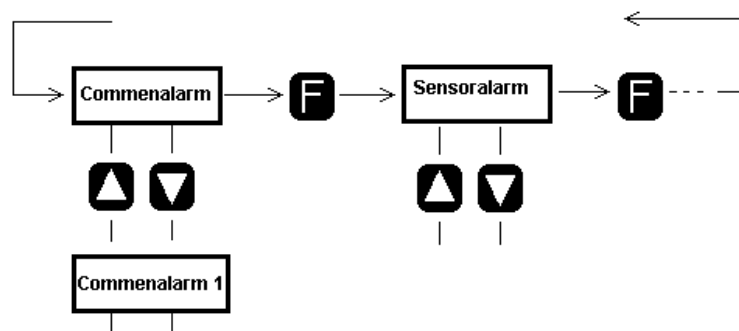
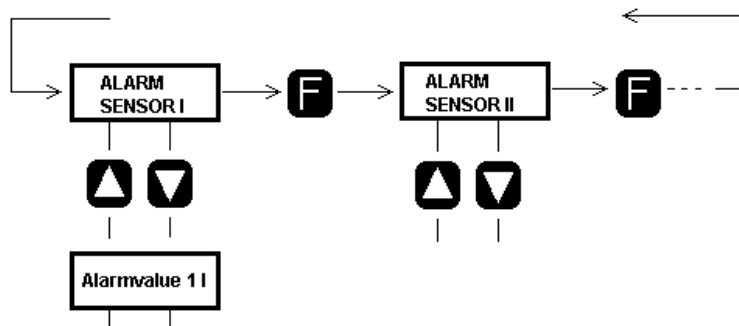
- From the basic display, you can access the other menus with the F key.
- Use the  and  keys to access the individual sub-menus.
- Press the  key once or twice to return to the main menu. Press it once more to return to the basic display.

Example:



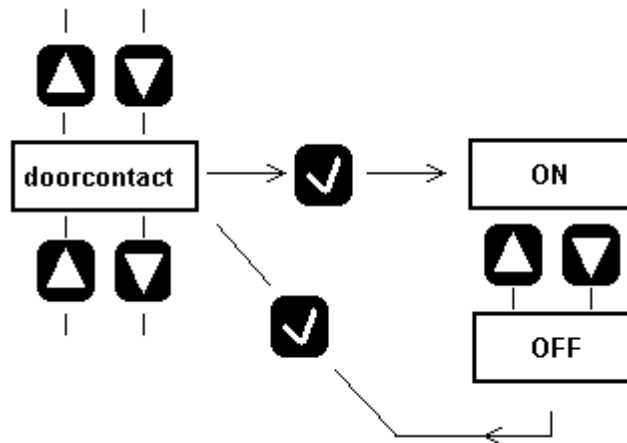

- Select the sub-menu you wish to edit.
- Press the  key and an arrow appears in front of the value to be set.
- Use the  and  keys to increase or decrease the value or to skip to the next option.
- Store the correct value by pressing .



Correcting the setting

You have changed a value with  and , but have not yet pressed the  to confirm. You can still retain the original setting.

Proceed as follows:

- 1 Press the  key.
- 2 Select the next sub-menu with the  and  keys.

6.2.1 Menu structure

The GMS *plus* has 11 menus:

- Main menu
- Alarm sensor I
- Alarm sensor II
- Temperature
- Common alarm
- Sensor alarm
- Calibration
- Sensor I
- Sensor II
- Setup
- Diagnosis

General overview

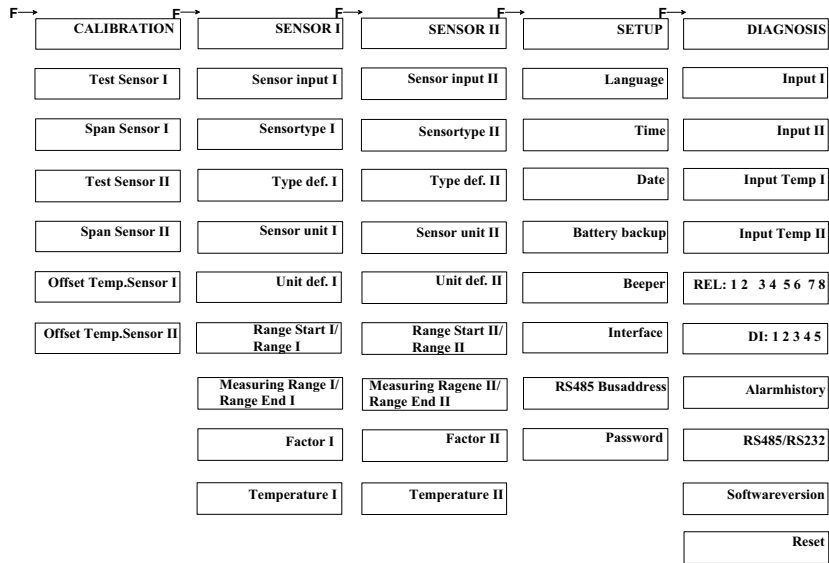
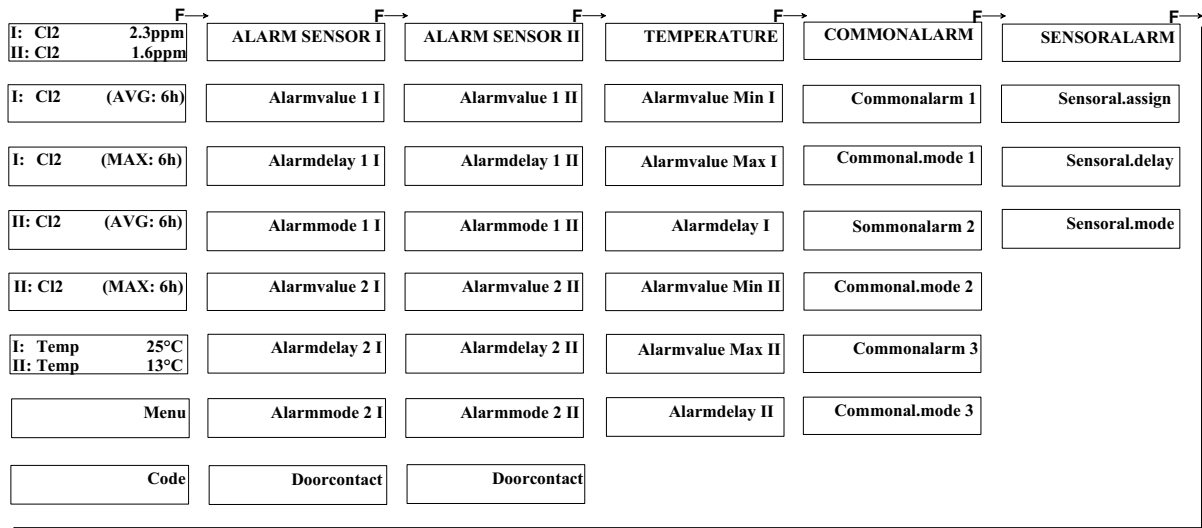

Display	Value range (factory setting, bold)	Description
Main menu (display example Cl₂)		
I: Cl ₂ 2.3ppm II: Cl ₂ 1.6ppm	Display example: Chlorine gas concentration of Sensor I = 2.3 ppm Chlorine gas concentration of Sensor II = 1.6 ppm	Current gas concentration value of the sensor channel I and II (chlorine, chlorine dioxide, ozone or passive mA sensor)
I: Cl ₂ (AVG: 8h) 2.3ppm	2.3ppm	Average gas concentration value of sensor I during the last 8 hours
I: Cl ₂ (MAX: 8h) 2.9ppm	2.9ppm	Maximum gas concentration value of sensor I during the last 8 hours
II: Cl ₂ (AVG:8h) 2.3ppm	2.3ppm	Average gas concentration value of sensor II during the last 8 hours
II: Cl ₂ (MAX:8h) 2.9ppm	2.9ppm	Maximum gas concentration value of sensor II during the last 8 hours
I: Temp 25°C II: Temp 13°C	I: Temp 25°C II: Temp 13°C	Temperature measurement of sensor channel I and II
Menu extended	concise extended	Concise: Displays the main menu only Extended: Displays all menus.
Code 000	000	Access code menu (000 – 999) Enter the access code, which is defined in menu "Code def.", in order to edit parameters.

Display	Value range (factory setting, bold)	Description
ALARM SENSOR I		Includes all settings for alarms 1 and 2 for sensor channel I
Alarmvalue 1	Measuring range start – End value 2.5ppm	Alarm value for alarm 1 of sensor 1
Alarmdelay 1 I	0.0 – 120/0 min 1.0min	Alarm delay for alarm 1 of sensor I
Alarmmode 1 I	N.O. unlatched N.C. unlatched N.O. latched ack N.C. latched ack	Alarm mode for alarm 1 of sensor 1 N.O. unlatched N.C. unlatched N.O. latched with confirmation N.C. latched with confirmation
Alarmvalue 2 I	Measuring range start – End value 5.0ppm	Alarm value for alarm 2 of sensor 1
Alarmdelay 2 I	0.0 – 120/0 min 1.0min	Alarm delay for alarm 2 of sensor I
Alarmmode 2 I	N.O. unlatched N.C. unlatched N.O. latched ack N.C. latched ack	Alarm mode for alarm 2 of sensor 1 N.O. unlatched N.C. unlatched N.O. latched with confirmation N.C. latched with confirmation
Doorcontact	OFF/ON	Enable the door contact input 1

Display	Value range (factory setting, bold)	Description
ALARM SENSOR II		Includes all settings for alarms 1 and 2 for sensor channel II
Alarmvalue 1 II	Measuring range start – End value 2.5ppm	Alarm value for alarm 1 of sensor II
Alarmdelay 1 II	0.0 – 120/0 min 1.0min	Alarm delay for alarm 1 of sensor II
Alarmmode 1 II	N.O. unlatched N.C. unlatched N.O. latched ack N.C. latched ack	Alarm mode for alarm 1 of sensor II N.O. unlatched N.C. unlatched N.O. latched with confirmation N.C. latched with confirmation
Alarmvalue 2 II	Measuring range start – End value 5.0ppm	Alarm value for alarm 2 of sensor II
Alarmdelay 2 II	0.0 – 120/0 min 1.0min	Alarm delay for alarm 2 of sensor II
Alarmmode 2 II	N.O. unlatched N.C. unlatched N.O. latched ack N.C. latched ack	Alarm mode for alarm 2 of sensor II N.O. unlatched N.C. unlatched N.O. latched with confirmation N.C. latched with confirmation
Doorcontact	OFF/ON	Enable the door contact input 2

Display	Value range (factory setting, bold)	Description
TEMPERATURE		Includes the temperature alarm settings for temperature sensor I and II
Alarmvalue Min I	0 – 50 (°C) 15 °C	Min. alarm value for temperature sensor I
Alarmvalue Max I	0 – 50 (°C) 35 °C	Max. alarm value for temperature sensor I
Alarmdelay I	0...30 min 10min	Alarm delay for min or max temperature alarm for temperature sensor I
Alarmvalue Min II	0 – 50 (°C) 15 °C	Min. alarm value for temperature sensor II
Alarmvalue Max II	0 – 50 (°C) 15 °C	Max. alarm value for temperature sensor II
Alarmdelay II	0 – 30 min 10min	Alarm delay for min or max alarm for temperature sensor II



Please note

The temperature alarms can be linked via a common alarm using a relay switch function.

Display	Value range (factory setting, bold)	Description
COMMONALARM		
Commonalarm 1	<input type="checkbox"/> AI1 Sensor I <input type="checkbox"/> AI2 Sensor I <input type="checkbox"/> AI1 Sensor II <input type="checkbox"/> AI2 Sensor II <input type="checkbox"/> Sensoralarm <input type="checkbox"/> Temp I min <input type="checkbox"/> Temp I max <input type="checkbox"/> Temp II min <input type="checkbox"/> Temp II max Multiple assignment possible No selection	Assignment of common alarm 1
Commonal.mode. 1	N.O. unlatched N.C. unlatched N.O. latched res N.C. latched res N.O. latched ack N.C. latched ack	Common alarm 1 alarm mode N.O. unlatched N.C. unlatched N.O. latched with reset N.C. latched with reset N.O. latched with confirmation N.C. latched with confirmation
Commonalarm 2	<input type="checkbox"/> AI1 Sensor I <input type="checkbox"/> AI2 Sensor I <input type="checkbox"/> AI1 Sensor II <input type="checkbox"/> AI2 Sensor II <input type="checkbox"/> Sensoralarm <input type="checkbox"/> Temp I min <input type="checkbox"/> Temp I max <input type="checkbox"/> Temp II min <input type="checkbox"/> Temp II max Multiple assignment possible No selection	Assignment of common alarm 2
Commonal.mode 2	N.O. unlatched N.C. unlatched N.O. latched res N.C. latched res N.O. latched ack N.C. latched ack	Common alarm 2 alarm mode N.O. unlatched N.C. unlatched N.O. latched with reset N.C. latched with reset N.O. latched with confirmation N.C. latched with confirmation

Display	Value range (factory setting, bold)	Description
Commonalarm 3	<input type="checkbox"/> Power Fail * <input type="checkbox"/> Common Error <input type="checkbox"/> Battery Err* <input type="checkbox"/> Batt empty* <input type="checkbox"/> Temp I min <input type="checkbox"/> Temp I max <input type="checkbox"/> Temp II min <input type="checkbox"/> Temp II max Multiple assignment possible No selection *Battery supply only	Assignment of common alarm 3
Commonal.mode. 3	N.O. unlatched N.C. unlatched N.O. latched res N.C. latched res N.O. latched ack N.C. latched ack	Common alarm 3 alarm mode N.O. unlatched N.C. unlatched N.O. latched with reset N.C. latched with reset N.O. latched with confirmation N.C. latched with confirmation

Display	Value range (factory setting, bold)	Description
SENSORALARM		
Sensoral.assign	<input type="checkbox"/> Sensor I <input type="checkbox"/> Sensor II <input type="checkbox"/> Temperature I <input type="checkbox"/> Temperature II Multiple assignment possible No assignment	Assignment of sensors to the sensor alarm
Sensoral.delay	0.0 – 5.0min 1.0 min	Sensor alarm delay time
Sensoral.mode	N.O. unlatched N.C. unlatched N.O. latched res N.C. latched res N.O. latched ack N.C. latched ack	Sensor alarm contact sensor alarm mode N.O. unlatched N.C. unlatched N.O. latched with reset N.C. latched with reset N.O. latched with confirmation N.C. latched with confirmation

Display	Value range (factory setting, bold)	Description
CALIBRATION		Sensor calibration and test
Test Sensor I	OFF TEST	Activating the sensor signal test
Span Sensor I	0 – 1/5/20 ppm No selection	Span calibration of sensor I (Chloratect sensors only)
Test Sensor II	OFF TEST	Activating the sensor signal test
Span Sensor II	0 – 1/5/20 ppm No selection	Span calibration of sensor II (Chloratect sensors only)
Offs.Temp.Sens I	-5 – +5 °C 0 °C	Offset correction of temperature sensor I
Offs.Temp.Sens II	-5 – +5 °C 0 °C	Offset correction of temperature sensor II

Display	Value range (factory setting, bold)	Description
SENSOR I		Setting the parameters for the sensor to be connected to sensor channel I
Sensor input I	Chloratect mA signal OFF (all menus for sensor channel I are hidden and the associated measured values are not displayed.)	Selection of sensors to be connected
Senso type I	For mA sensors: Cl2 , ClO ₂ , O ₃ , SO ₃ , HCL, ---- (variably definable type, max. 4 positions) For Chloratect sensors (µA-Input): Cl2 , ClO ₂ and O ₃	Setting the sensor type (i.e. the gas to be measured)
Type def I	XXXX	Enter the sensor type for sensor I for variable definition (A – Z, a – z, 0 – 9) 4 positions (freely selectable)
Sensor unit I	ppm ml/m ³ ---- (unit freely selectable, max. 4 positions for mA sensors)	Sensor I display unit
Unit def. I	XXXX	Entering the sensor unit for mA sensor I for variable definition (A – Z, a – z, 0 – 9) 4 positions (freely selectable)
Range Start I	0 – 999 (mA sensor) 0.0	Measuring range start value for mA signal sensor I
Measuring Range I/ Range End I	For mA sensors: 0 – 999 Display format 000.0 for value over 100 Display format 000 for values higher than 100 or For Chloratect sensors: end value 1.5 or 20 ppm O ₃ => 1 ppm Cl ₂ => 5 ppm / 20 ppm ClO ₂ => 5 ppm / 20 ppm	Setting the measuring range for Chloratect sensors and/or setting the measuring range end value for mA sensors
Factor I	0.1 – 4.0 (for mA signal sensor) 1.0	Factor for adjusting the measuring range of sensor I to range I of the GMS <i>plus</i>
Temperature I	OFF/ON	Temperature measurement I on/off

Display	Value range (factory setting, bold)	Description
SENSOR II		Setting the parameters for the sensor to be connected to sensor channel II
Sensor input II	Chloratect mA signal OFF (all menus for sensor channel I are hidden and the associated measured values are not displayed.)	Selection of sensors to be connected
Sensortype II	For mA sensors: Cl2 , ClO2, O3, SO3, HCL, ---- (variably definable type, max. 4 positions) For Chloratect sensors (μ A-Input): Cl2 , ClO2 and O3	Setting the sensor type (i.e. the gas to be measured)
Type def II	XXXX	Enter the sensor type for sensor II for variable definition (A – Z, a – z, 0 – 9) 4 positions (freely selectable)
Sensor unit II	ppm ml/m ³ ---- (unit freely selectable, max. 4 positions for mA sensors)	Sensor II display unit
Unit def. II	XXXX	Entering the sensor unit for mA sensor II for variable definition (A – Z, a – z, 0 – 9) 4 positions (freely selectable)
Range Start II	0 – 999 (mA sensor) 0.0	Measuring range start value for mA signal sensor II
Measuring Range II/ Range End II	For mA sensors: 0...999 Display format 000.0 for value over 100 Display format 000 for values higher than 100 or For Chloratect sensors: end value 1.5 or 20 ppm O3 => 1 ppm Cl2 => 5 ppm / 20 ppm ClO2 => 5 ppm / 20 ppm	Setting the measuring range for Chloratect sensors and/or setting the measuring range end value for mA sensors
Factor II	0.1 – 4.0 (for mA signal sensor) 1.0	Factor for adjusting the measuring range of sensor II to range II of the GMS <i>plus</i>
Temperature II	OFF/ON	Temperature measurement II on/off

Display	Value range (factory setting, bold)	Description
SETUP		General GMS <i>plus</i> settings.
Language	German , English, French, Dutch, Spanish	Language setting
Time	00:00 – 24:00	Setting the time
Date	current date 12.12.05	Setting the date
Battery supply	OFF/ON	Enabling the digital inputs for the battery supply (24 V units only)
Beeper	[] Common alarm [] Sensoralarm [] Alarm I 1/2 [] Alarm II 1/2 Multiple assignment possible No selection	Select which alarms activate the internal signal transmitter (beeper)
Interface	OFF Printer Bus operation	Select the interface mode RS232 protocol printer or RS485 bus connection, etc.
RS485 Busadr	00 - 31	RS485 bus address selection (interface = bus operation only)
Code def	000 – 999 Access code not required to set parameters if set to "000" If another value is entered, the parameters may only be changed after entering this code into the main menu "Code".	Definition of an access code to protect against unauthorized access.

Display	Value range (factory setting, bold)	Description
DIAGNOSIS		Error diagnostics
Input I	<p>for mA sensors in mA for measuring range start => 4mA for measuring range end => 20mA for sensor error < 4 mA</p> <p>Chlorine: for 0ppm => approx. 1µA for 5ppm => 16.5µA for 20ppm => 58.7µA for sensor error <0.1µA</p> <p>Chlorine Dioxide: for 0ppm => approx. 1µA for 5ppm => 9µA for 20ppm => 30.9µA for sensor error <0.1µA</p> <p>Ozone: for 0ppm => approx. 0.3µA for 5ppm => 1.6µA for sensor error <0.1µA</p>	<p>The current sensor signal is displayed</p> <p>for Chloratect sensors in µA for mA sensors in mA</p>
Input II	See Input I	See Input I
Input Temp I	13°C	Temperature on temperature sensor I (uncalibrated)
Input Temp II	25°C	Temperature on temperature sensor II (uncalibrated)
REL: 1 2 3 4 5 6 7 8	<p>Rel 1 Alarm 1 Rel 2 Alarm 2 I Rel 3 Alarm 1 II Rel 4 Alarm 2 II Rel 5 Common Alarm 1 Rel 6 Common Alarm 2 Rel 7 Common Alarm 3 Rel 8 Sensoralarm</p> <p>0 0 0 0 0 0 0 0</p>	<p>Current signal condition at relay outputs 1 – 8</p> <p>0 = relay off 1 = relay on</p>

Display	Value range (factory setting, bold)	Description															
DI: 1 2 3 4 5	DI1 - door contact sensor I DI2 - door contact sensor II DI3 - external acknowledgement DI4 - see table DI5 - see table <table border="1" style="margin-left: 20px;"> <thead> <tr> <th>DI4</th> <th>DI5</th> <th></th> </tr> </thead> <tbody> <tr> <td>0</td> <td>0</td> <td>Battery empty</td> </tr> <tr> <td>1</td> <td>0</td> <td>Power failure</td> </tr> <tr> <td>0</td> <td>1</td> <td>Battery error</td> </tr> <tr> <td>1</td> <td>1</td> <td>Power/Battery ok</td> </tr> </tbody> </table> 0 = contact opened 1 = contact closed 0 0 0 1 1	DI4	DI5		0	0	Battery empty	1	0	Power failure	0	1	Battery error	1	1	Power/Battery ok	Current signal conditions at digital inputs 1 – 5 are displayed
DI4	DI5																
0	0	Battery empty															
1	0	Power failure															
0	1	Battery error															
1	1	Power/Battery ok															
Alarm history	SF 22.03.08.32 - sensor error on 22.3. at 8:32 AM C1 21.02.04.22 - Common alarm on 21.2. at 4:22 AM C2 18.01.06.30 - Common alarm on 18.1. at 6:30 AM Press the <input checked="" type="checkbox"/> key to view errors. SF 22.03. 08.32	Displays the last five alarms with date and time.															
RS485/RS232	TxD Transmit Data RxD Receive Data	Current RS485 interface activity															
Software release	EAE1052 . . .	Displays the installed software version Number, release, date, country (alternating)															
Reset	Press the <input checked="" type="checkbox"/> key to restart No selection	Menu to restart the unit															

6.3 Errors and remedies



Error messages

The following table shows and explains all possible error messages which can be displayed. If several errors occur at the same time, the corresponding messages appear alternately in succession. When the error has been remedied, the error message is automatically deleted.

If you are unable to remedy the error yourself, please contact your contractual partner.

Display	Color		Meaning	Measures
POWER / BAT.	green	constant	Mains voltage and/or 24 V supply present	---
		does not light up	No power supply	Switch on, check external fuse.
			Device fuse defective	Check the power supply and replace fuse (Electrician).
			GMS <i>plus</i> power unit defective	Send unit back to factory.
			For 24 V-GMS <i>plus</i> : 24 V supply voltage unavailable or battery empty	Check battery supply
Measurement display		flashing	Lower point of range missed by more than 5 %	Adjust zero point for Chloratec sensor. Check ambient conditions of the cell (temperature, humidity).
			Range exceeded by more than 5 %	 CAUTION! Substantial gas escape!

Display	Color		Meaning	Measures
ALARM 1 I	red	constant	Sensor I, preliminary alarm, alarm relay triggered	Follow alarm plan. Remove cause of alarm. Clear alarm ( key or external key at input ext. acknowledgement for latched alarms). Use personal protection equipment. As soon gas concentration is back to normal, rinse sensor with distilled water.
		flashing fast	Sensor I, preliminary alarm, door open, alarm relay not triggered	
		flashing slowly	Sensor I preliminary alarm latched relay triggered	
ALARM 2 I	red	constant	Sensor I, main alarm, alarm relay triggered	See 4.3 "Alarms" on page 24.
		flashing fast	Sensor I, main alarm, door open, alarm relay not triggered	
		flashing slowly	Sensor I preliminary alarm latched relay triggered	
ALARM 1 II	red	constant	Sensor II, preliminary alarm, alarm relay triggered	
		flashing fast	Sensor I, preliminary alarm, doors open, alarm relay not triggered	
		flashing slowly	Sensor II preliminary alarm latched relay triggered	
ALARM 2 II	red	constant	Sensor II, main alarm, alarm relay triggered	
		flashing fast	Sensor II, main alarm, door open, alarm relay not triggered	
		flashing slowly	Sensor II preliminary alarm latched relay triggered	

Display	Color		Meaning	Measures
COMMON 1 COMMON 2 COMMON 3	red	flashing or constant	Common alarm 1 active common relay 1 triggered	Follow alarm plan. For "latched" mode: After removing the cause, clear with the  key or external acknowledge key. Remove cause of alarm. See 4.3 "Alarms" on page 24.
			Common alarm 2 active common relay 2 triggered	
			Common alarm 3 active common relay 3 triggered	
SENSOR 	red	constant	Sensor current too low or too high	Replenish the electrolyte in the sensors. Check the μA signal in the menu Diagnosis. Check the cable connection between the sensors and the GMS <i>plus</i> . Sensor not yet run in; calibrate after run-in period. For " latched " mode: After removing the cause, clear with the  key or external acknowledge key.
		flashing	Sensor alarm latched Sensor current too low or too high	



Please note

The accuracy of the alarm function is not certain during the run-in period.

Error diagnostics on Chloratec sensors

Using a digital voltmeter, the DC voltages on the measuring cell input can be measured (terminals 21 – 22 and 25 – 26). They are used to trouble-shoot the sensors. The voltages are typical values for appropriate zero balance currents:

- Cl_2^- and ClO_2 sensor at 1 μA : approx. 1.1 – 1.3 V=
- O_3 -sensor at 0.3 μA : approx. 0.35 – 0.45 V=



Please note

The sensor is defective or improperly enabled if the measured voltage deviates from the specified values!

Display error message

Display	Meaning	Measures
"Sensor I ?"	Sensor I signal too low or too high	Check electrolyte supply Check cable connection to the sensor. Check sensor signal in the Diagnosis menu.
"Sensor II?"	Sensor I signal too low or too high	
"Temp.I?"	Temperature sensor I signal outside the range	Check sensor/cable connection, sensor resistors: 0 °C => 1000 Ohm 10 °C => 1038.5 Ohm 20 °C => 1077 Ohm 50 °C => 1192.5 Ohm
"Temp.II?"	Temperature sensor II signal outside the range	
"Range I ?"	Alarm values of sensor I outside the measurement range	Change the alarm values in the menu.
"Range II ?"	Alarm value of sensor II outside the measurement range	
"mA out ?"	Load on mA output 1, 2 or 3 greater than 600	Check mA connection lines; may have a open circuit or load is too high
"Clock ?"	Real-time clock error	Send to us for repair
"battery ?"	Battery capacity too low or battery defective (i.e. temperature > 45 °C)	Change battery and reduce ambient or battery temperature
"Power fail ?"	Battery supply mains voltage off	Switch power on
"Batt empty "	Mains voltage off and battery empty	Switch power on
"EPROM ?"	Incompatible software was installed or the system is defective.	Send to us for repair

7. Maintenance

7.1 Routine maintenance



Please note

The liability for defects is only valid if maintenance work is performed as specified. Adhere to the appropriate standards, regulations and locally applicable guidelines.

Maintenance overview

Activity	Period/Interval
Electrolyte supply for Chloratec sensors	every three months
Sensors	every six months
Gas monitoring system GMS <i>plus</i>	every six months

The sensors and the GMS *plus* must be routinely inspected.

Maintenance should be carried out every six months by trained operating personnel or under maintenance contract with Evoqua Water Technologies GmbH.

Maintenance will include inspection of the sensor's function, the electrolyte level in the measuring cell and electrical operational safety.



Please note

The electrolyte supply must be checked more frequently if the room temperature is above 25 °C.

Battery supply (optional)

Replace the batteries approx. every 3 years.

4 – 20 mA sensors

If the 4 – 20 mA sensors are made by different manufacturers, the specifications in their operating manuals must be observed.

7.2 Electrolyte supply for Chloratec sensors



A MAX mark
B MIN mark

Refilling the sensor



- 1 Remove the electrolyte reservoir.

Please note

Do not separate the sensor being refilled with electrolyte from the sensor cable.

- 2 Pour away the old electrolyte to avoid increasing the electrolyte concentration.
Do not rinse out the electrolyte reservoir!
- 3 Fill with new solution up to the MAX mark.



Please note

Use only our original electrolyte solution!

The electrolyte supply must be checked more frequently if the room temperature is above 25 °C.

Part No.	Description
W3T173163	Electrolyte solution for Chlorine
W3T173163	Electrolyte solution for Chlorine Dioxide
W3T169304	Electrolyte solution for Ozone

7.3 Replacing a fuse or battery



Warning!

Risk involving electric current.

Disconnect the power supply before opening the housing.
Only trained electricians are permitted to open the housing.

7.3.1 Replacing the fuse

The device fuse must be inspected if:

- The power LED is off.
- The screen does not display anything although the power supply is connected.

Proceed as follows:

- 1 Disconnect the unit from the power supply.
- 2 Remove the cover of the GMS *plus* and unplug the connection cable to the motherboard.
- 3 Check the fuses, replace if necessary:
F1, F2 plug-in fuse 0.63 AT
(for motherboard 230/115 V or
for 24 V units 1.6 AT)
2 Spare fuses are provided on the side of the unit.
- 4 Plug in the connection cable and replace the cover.

7.3.2 Replacing the battery



Please note

If the time is incorrect after a power failure, this typically means the lithium battery is empty.

If the clock stops

- 1 Disconnect the unit from the power supply.
- 2 Remove the cover of the GMS *plus* and unplug the connection cable to the motherboard.
- 3 Replace the battery: Type VARTA CR2032
- 4 Plug in the connection cable and replace the cover.

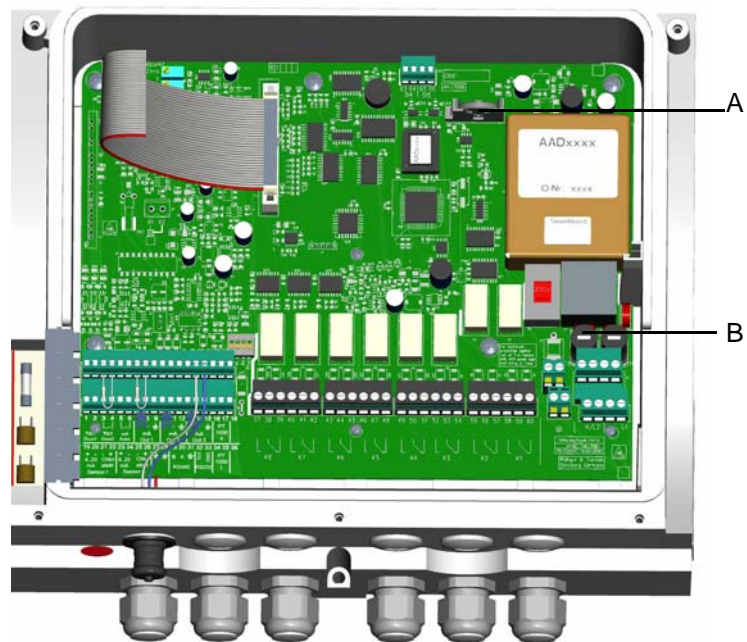
5 Connect the unit and set the time/date.

A Battery
B Fuse



Attention!

Environmental hazard!

Do not throw away or burn the batteries!

The batteries must be disposed of in accordance with environmental protection regulations.

1. To this purpose public or private waste disposal companies should be employed.
2. If such an organisation is not available or the products are not accepted, the product can be returned to Evoqua Water Technologies GmbH after prior consultation.

7.4 Recommended spare parts



Warning!

For reasons of safety, only use original spare parts.

Please contact our customer service department if you need any spare parts.

Part No.	Description
W3T173163	Electrolyte Chlorine (Cl ₂)
W3T173163	Electrolyte Chlorine dioxide (ClO ₂)
W3T169304	Electrolyte Ozone (O ₃)
W3T158780	GMS <i>plus</i> electronic PCB 115/230 V
W3T158781	GMS <i>plus</i> electronic PCB 24 V
W3T164807	Chloratect sensor cable 2 m
W3T164808	Chloratect sensor cable 10 m
W3T291559	Sensor cable 4 – 20 mA sensor 3 m
W3T291560	Sensor cable 4 – 20 mA sensor 10 m
W3T172029	Temperature sensor Pt1000 0.9 m
W3T167627	Sensor holder (Chloratect sensor)
W3T163651	Sensor cover (Chloratect sensor)
W3T158770	GMS <i>plus</i> Battery supply (complete)
W3T164813	Spare battery for battery supply 6 V/3 Ah or 12 V/3 Ah (2x necessary)
W2T506424	GMS <i>plus</i> fuse 115 V/230 V (630 mA)
W2T506499	GMS <i>plus</i> fuse 24 V (1.6 A)
W2T505996	Fuse for battery supply 3 A
W3T166294	Operating front incl. display and cover
W3T172625	CR2032 battery
W2T504551	Sensor cable extension (2pol. shielded) LIYCY 2x 0.75 mm ²
W3T165531	Junction box for sensor cable extension

8. Accessories and spare parts

8.1 Gas monitoring system GMS *plus*

Part No.	Description	
W3T158771	Gas monitoring system GMS <i>plus</i>	230 V
W3T158772	Gas monitoring system GMS <i>plus</i>	115 V
W3T158773	Gas monitoring system GMS <i>plus</i>	24 V
W3T158770	GMS <i>plus</i> battery supply	98 – 264 V

8.2 Chloratec sensors and sensor kits

Chloratec sensors

Part No.	Chloratec Sensors	Symbol	Sensor range ppm
W3T163650	Chlor	Cl ₂	0 – 5/0 – 20
W3T163650	Chlorine dioxide	ClO ₂	0 – 5/0 – 20
W3T171360	Ozone	O ₃	0 – 1

Sensor kits

Part No.	Description		
W3T158797	Sensor kit chlorine ^{*)}	0–5/0–20 ppm	2 m
W3T158797	Sensor kit chlorine dioxide ^{*)}	0–5/0–20 ppm	2 m
W3T158798	Sensor kit ozone ^{*)}	0–1 ppm	2 m
W3T275585	Sensor kit chlorine ^{*)}	0–5/0–20 ppm	10 m
W3T275585	Sensor kit chlorine dioxide ^{*)}	0–5/0–20 ppm	10 m
W3T275584	Sensor kit ozone ^{*)}	0–1 ppm	10 m

^{*)} Sensor kit comprising:
Sensor, cable, electrolyte, junction box, screwdriver, fittings,
sensor cover

8.3 mA sensors and sensor kits

mA sensors

Part No.	Gas	Symbol	Sensor range ppm
W3T292478	Chlorine	Cl ₂	0 – 10
W3T292492	Sulfur dioxide	SO ₂	0 – 10
W3T292503	Sulfur dioxide	SO ₂	0 – 20

Sensor kits

Part No.	Description		
W3T302953	Sensor kit GMS <i>plus</i> sulfur dioxide ^{*)}	0 – 10 ppm	3 m
W3T302955	Sensor kit GMS <i>plus</i> chlorine ^{*)}	0 – 10 ppm	3 m
W3T315456	Sensor kit GMS <i>plus</i> sulfur dioxide ^{*)}	0 – 10 ppm	10 m
W3T315458	Sensor kit GMS <i>plus</i> chlorine ^{*)}	0 – 10 ppm	10 m

^{*)} Sensor kit comprising:
Sensor, cable, junction box, fittings

8.1 Temperature sensors und sensor kits

Temperature sensors

Part No.	Description	
W3T172029	Temperature sensor Pt1000	0,72 m
W3T164558	Temperature sensor Pt1000	10 m

Sensor kits

Part No.	Description		
W3T158782	Sensor kit GMS <i>plus</i> Temperature Pt1000	0–50°C	0,72 m
W3T315457	Sensor kit GMS <i>plus</i> Temperature Pt1000	0–50°C	10 m

^{*)} Sensor kit comprising:
Multi-Sensor, junction box and fittings

9. Wiring diagrams

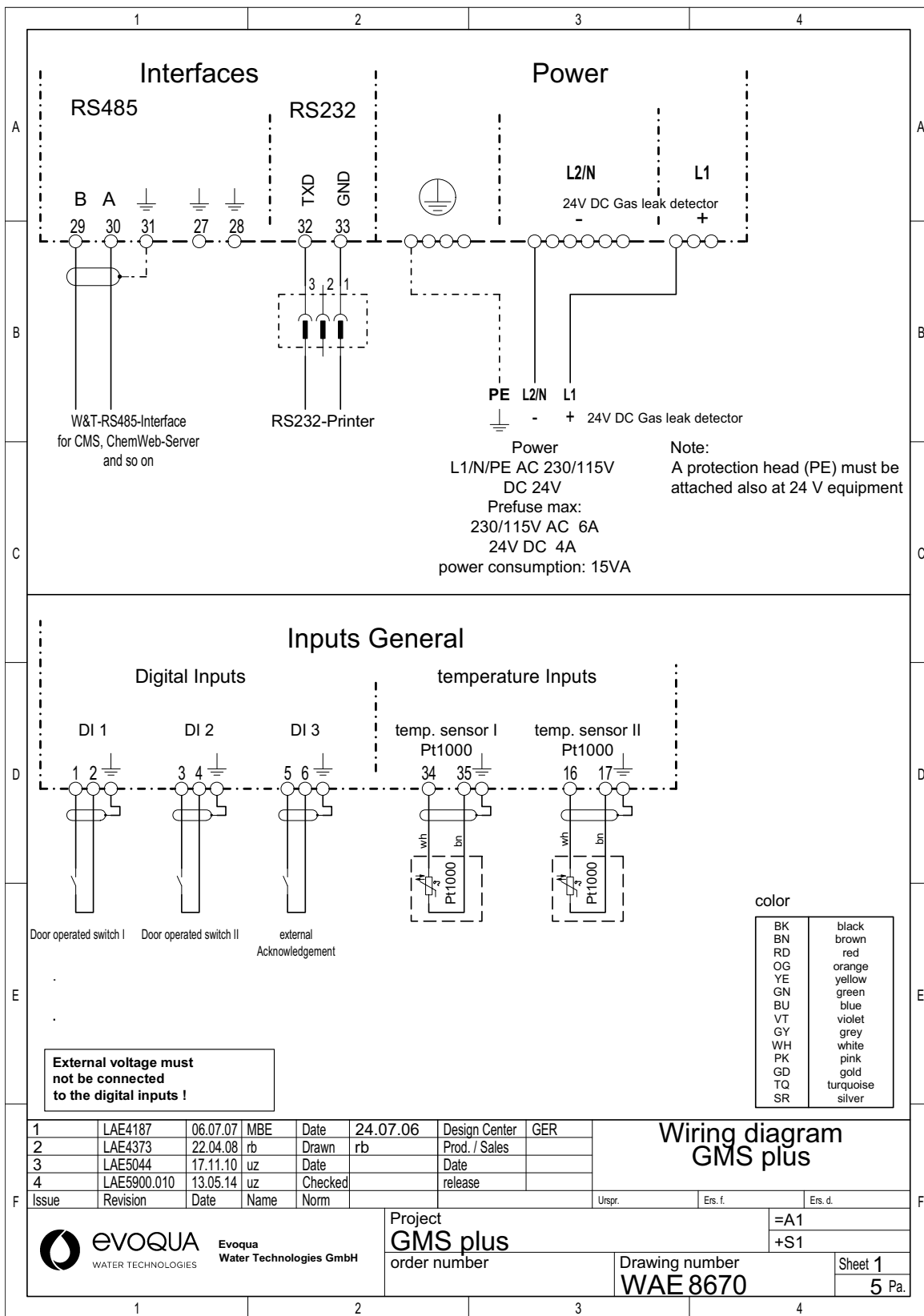

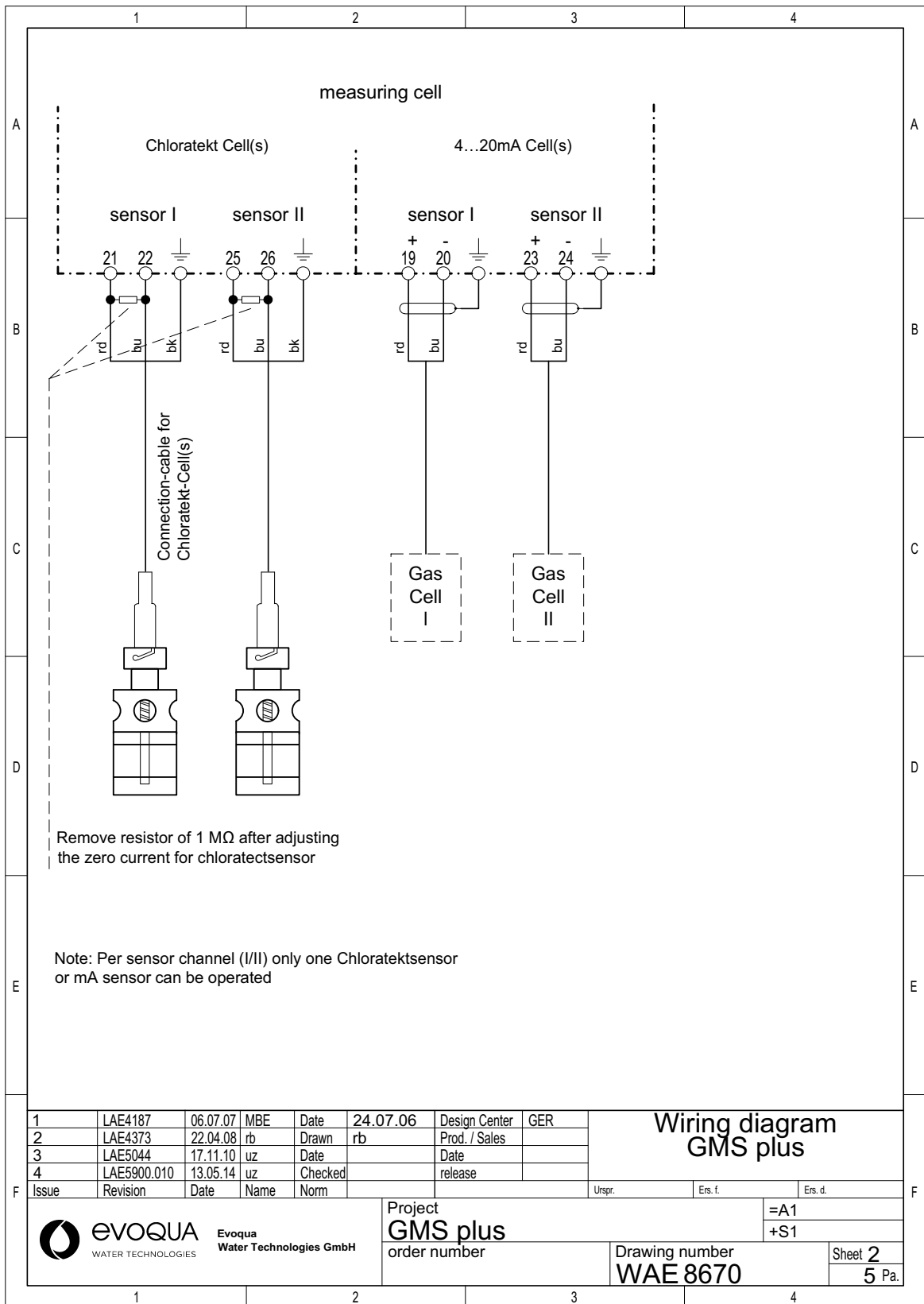

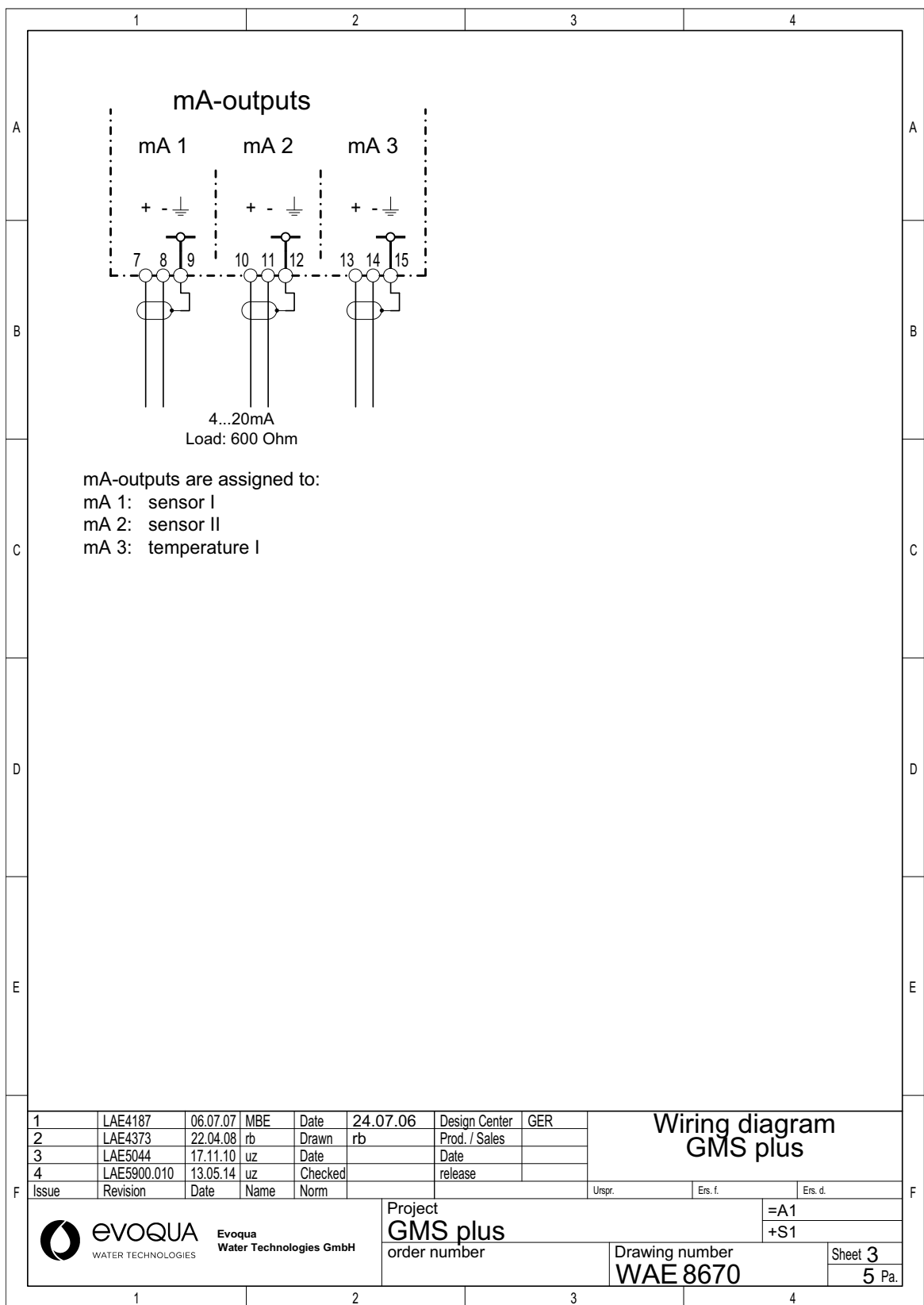

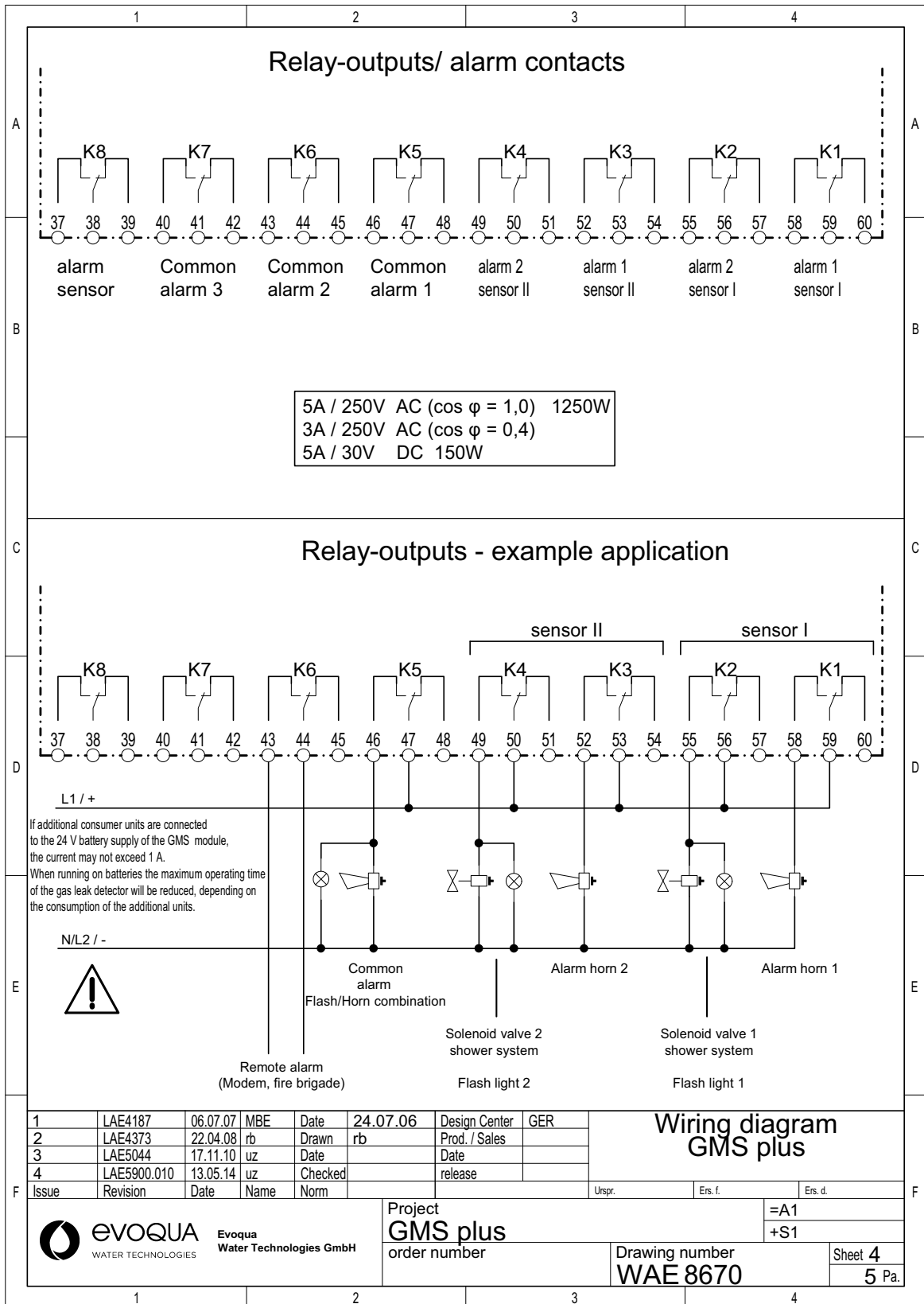

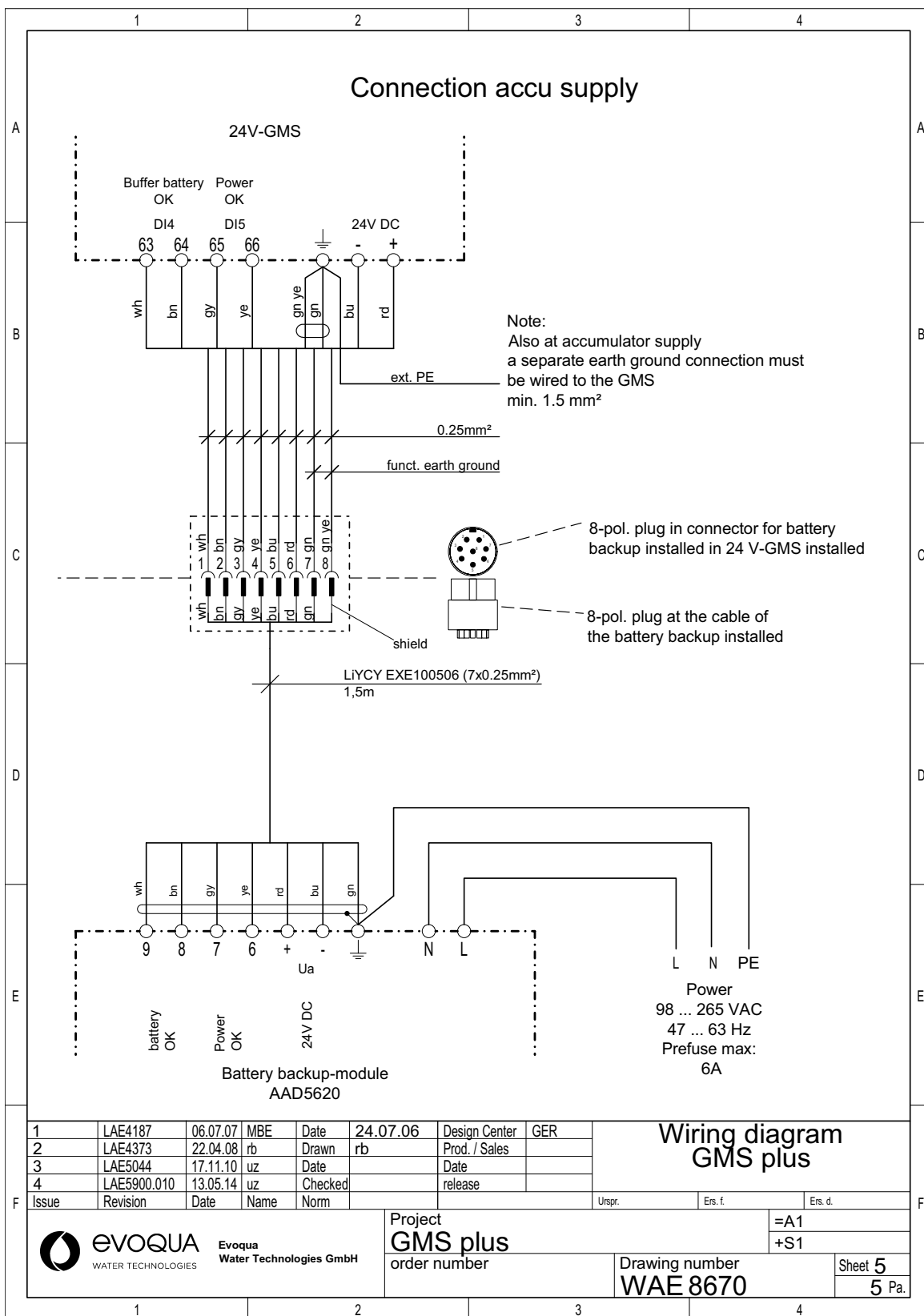

10.Declaration of conformity



EG-Konformitätserklärung EC Declaration of Conformity Déclaration CE de conformité

No. MAE1250

Ausgabe/issue/édition 05

Hersteller/Manufacturer/Constructeur: Evoqua Water Technologies GmbH
Anschrift/Address/Adresse: Auf der Weide 10, D-89312 Günzburg
Produktbezeichnung: GMS *plus*
Product description: GMS *plus*
Description du produit: GMS *plus*

Das bezeichnete Produkt stimmt in der von uns in Verkehr gebrachten Ausführung mit den Vorschriften folgender europäischer Richtlinien überein:

The product described above in the form as delivered is in conformity with the provisions of the following European Directives:

Le produit désigné est conforme, dans la version que nous avons mise en circulation, avec les prescriptions des directives européennes suivantes :

- 2014/30/EU Richtlinie des Europäischen Parlaments und des Rates vom 26. Februar 2014 zur Harmonisierung der Rechtsvorschriften der Mitgliedstaaten über die elektromagnetische Verträglichkeit.
Directive of the European Parliament and of the Council of 26 February 2014 on the approximation of the laws of the Member States relating to electromagnetic compatibility.
Directive du Parlement européen et du Conseil du 26 février 2014 relative au rapprochement des législations des Etats membres concernant la compatibilité électromagnétique.
- 2014/35/EU Richtlinie des Europäischen Parlaments und des Rates vom 26. Februar 2014 zur Harmonisierung der Rechtsvorschriften der Mitgliedstaaten betreffend elektrische Betriebsmittel zur Verwendung innerhalb bestimmter Spannungsgrenzen.
Directive of the European Parliament and of the Council of 26 February 2014 on the harmonisation of the laws of Member States relating to electrical equipment designed for use within certain voltage limits.
Directive du Parlement européen et du Conseil du 26 février 2014 concernant le rapprochement des législations des Etats membres relatives au matériel électrique destiné à être employé dans certaines limites de tension.
CE-Kennzeichnung / *CE marking* / **Marquage CE: 2016**



Die Konformität mit den Richtlinien wird nachgewiesen durch die Einhaltung der in der Nachweisdokumentation aufgelisteten Normen.

Evidence of conformity to the Directives is assured through the application of the standards listed in the relevant documentation.

La conformité avec les directives est assurée par le respect des normes listés dans la documentation technique correspondante.

Benannte Person für technische Unterlagen:

Authorized person for the technical file:

Personne désignée pour la documentation technique:

Name / name / nom: Evoqua Water Technologies GmbH

Adresse / address / adresse: Auf der Weide 10, D-89312 Günzburg

Günzburg, den / the 2016-04-20

Evoqua Water Technologies GmbH

Klaus Andre
Technischer Leiter / Director Engineering

Unterschrift
signature / signature

Helmut Fischer
Leiter QM / Quality Manager

Unterschrift
signature / signature

Diese Erklärung bescheinigt die Übereinstimmung mit den genannten Richtlinien, ist jedoch keine Beschaffenheits- oder Haltbarkeitsgarantie nach §443 BGB. Die Sicherheitshinweise der mitgelieferten Produktdokumentation sind zu beachten.

This declaration certifies the conformity to the specified directives but does not imply any warranty for properties. The safety documentation accompanying the product shall be considered in detail..

La présente déclaration atteste de la concordance avec les directives citées, elle n'offre cependant pas de garantie quant à la nature ou la durabilité selon l'article 443 du code civil allemand. Les consignes de sécurité de la documentation du produit fournie sont à respecter.



Wallace & Tiernan® Products worldwide

Australia

+61 1300 661 809
info.au@evoqua.com

Canada

+1 905 944 2800
wtoc.can@evoqua.com

China

+86 21 5118 3777
sales.cn@evoqua.com

France

+33 1 41 15 92 20
wtfra@evoqua.com

Germany

+49 8221 9040
wtger@evoqua.com

Singapore

+65 6559 2600
sales.sg@evoqua.com

UK

+44 300 124 0500
info.uk@evoqua.com

USA

+1 800 524 6324
wt.us@evoqua.com



Wallace & Tiernan®
an EVOQUA brand



Auf der Weide 10, 89312 Günzburg, Germany

+49 (8221) 904-0 www.evoqua.com

In some countries, DEPOLOX, OSEC, Barrier, Chem-Ad and Wallace & Tiernan are trademarks of Evoqua, its subsidiaries or affiliated companies.

No part of this document may be reproduced in any form (printed, photocopy, microfilm, or any other procedure) or saved, processed, copied, or distributed using electronic data systems - without the express prior written consent of Evoqua Water Technologies GmbH.

All information in this document is considered reliable and corresponds to the generally applicable technical standards. Evoqua assumes no responsibility for the completeness of this information. Users are responsible for making sure that the product is suitable for specific applications. Evoqua assumes no liability for specific or indirect damage or consequential damage arising from the sale, resale or misuse of its products.

© 2020 Evoqua Water Technologies GmbH Subject to modifications

WT.050.455.000.DE.IM.0320
W3T159065 Issue 20-0320