

APPENDIX X

RF-2 EQUIPMENT DRAWINGS AND  
SPECIFICATIONS

FOR

SIEMENS INDUSTRY, INC.

PARKER REACTIVATION FACILITY

PARKER, ARIZONA

Revision 1  
April 2012

## TABLE OF CONTENTS

<u>ITEM</u>	<u>DESCRIPTION</u>
Dwg. A-30280	Weigh Belt Feeder
Dwg. F-001	RF-2 Reactivation Furnace
Dwg. P-007	RF-2 Afterburner
Dwg. DJ95-539-1	Arrangement CGS Venturi Scrubber/Absorber
Dwg. DJ95-539-2	Specifications, Nozzle Schedule & Notes CGS Venturi Scrubber/Absorber
Dwg. DJ95-540-1	CGS Wet Electrostatic Precipitator
Dwg. C25923F1	Induced Draft Fan
Dwg. D95-75-S1-1	Dual Wall Stack & Details
Dwg. 1541-M-001	Stack Port Arrangement
	North American Model 6422 Burner Information
	North American Model 6514 Burner Information
Dwg. ASC303-03	CEMS Flow Diagram
	Ametek O <sub>2</sub> Analyzer Specifications
	Thermox O <sub>2</sub> Analyzer Specifications
	Siemens Ultramat 23 CO Analyzer Specifications
	TECO Model 48C CO Analyzer Specifications

DRAWING A-30280  
WEIGH BELT FEEDER

Revision 1  
April 2012

**NOTES:**

1. ALLOW APPROX. 24" OF CLEARANCE ON "DOOR SIDE" OF UNIT, FOR REMOVAL OF CONVEYOR FROM CABINET.
2. DO NOT IMPOSE STRUCTURAL LOADS OR VIBRATION TO THE UNIT, AT THE INFEED AND DISCHARGE CONNECTIONS.
3. ELECTRONIC INSTRUMENT ENCLOSURE, TO BE MOUNTED REMOTELY.
4. GED TO BE FEEDER MOUNTED AND WIRED.
5. SCR UNIT MOUNTED REMOTELY IN SAME AREA AS FEEDER.

**SPECIAL EQUIPMENT:**

10. ENCLOSURE IS 316L SS, WITH A UNIFORM GLASS BEADED SURFACE FINISH EQUIVALENT TO ZB & BOLTED TO SPILL PAN (316L SS).
11. CONVEYOR FRAME AND ROD TYPE WEIGH DECK ARE 304 SS.
12. SIDE DOOR IS HINGED, 3/8" THICK LEXAN.
13. NO PAINT ON STAINLESS STEEL PARTS.
14. CONVEYOR DRIVE IS TOP MOUNTED.
15. CONVEYOR BELT IS F.D.A. APPROVED
16. LOAD CELL IS HERMETICALLY SEALED WITH QUICK DISCONNECT.
17. TAIL PULLEY IS 316L SS (OPTIONAL) WITH SS SCRAPER ASY. WITH DELRIN INSERT & AUTO-BELT TENSIONING.
18. HEAD PULLEY IS 316L SS (OPTIONAL).
19. SHOCK MOUNTS PROVIDED AS SHOWN.
20. ALL METEAL CONTACT PARTS ARE CONSTRUCTED FROM 316L SS.
21. SKIRT BOARDS HAVE BUNA-N SEAL STRIPS.

TAG NO: C-16  
CONVEYOR WEIGH BELT

**ORIGINAL**

FILE I.D. = 111758  
SHOP ORDER = M03138-000

AL SUP ORDER WAS 316L SS 316L SS  
DVA/7/20/06, CHANGED SERIAL NUMBER  
LA 7/26/06/REVISED PER CUSTOMER MARK UP

**Metrotek**  
METROTEK INDUSTRIES, INC.  
CORPORATION

REV. NO. 2  
DATE 1/12/96

SCALE 1/8" = 1"

DATE 1/12/96

LEFT HAND ACCESS SHOWN

OUTLINE DWG 12"-951  
GRAVIMETRIC FEEDER  
TOTALLY ENCLOSED (SPILL PAN)

IND. METAL VES CARBON  
METAL  
CENTRAL HANSON ENVIRONMENTAL  
SOMERVILLE, NJ  
CUSTOMER ORDER NO. 9503-022  
WORKING DRAWING NO. 950-MC-2-27114

CONV. SPEED 10.07 FPM  
CURRENT 3000 LBS/HR  
MCT. CARBON  
3000-36 PCF

UNLESS OTHERWISE SPECIFIED  
MATERIALS  
1. CARBON  
2. SURFACE TREATMENT  
3. SURFACE TREATMENT  
4. SURFACE TREATMENT

CONFORMS TO 2010

THIS DRAWING AND ALL INFORMATION CONTAINED THEREON ARE THE PROPERTY OF METROTEK INDUSTRIES, INC. AND SHALL BE KEPT CONFIDENTIAL AND NOT TO BE REPRODUCED OR TRANSMITTED IN ANY FORM OR BY ANY MEANS, ELECTRONIC OR MECHANICAL, INCLUDING PHOTOCOPYING, RECORDING, OR BY ANY INFORMATION STORAGE AND RETRIEVAL SYSTEM, WITHOUT THE WRITTEN PERMISSION OF METROTEK INDUSTRIES, INC. AND SHALL BE IMMEDIATELY RETURNED TO METROTEK INDUSTRIES, INC. UPON REQUEST.

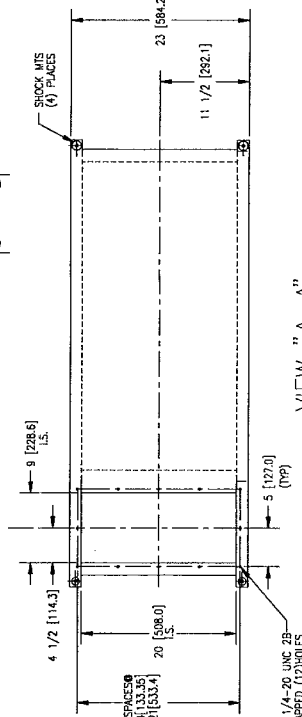
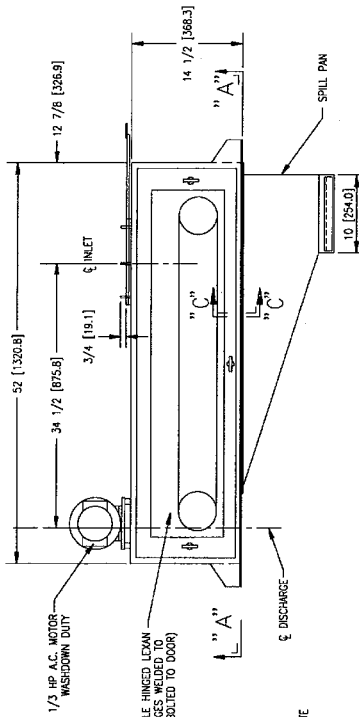
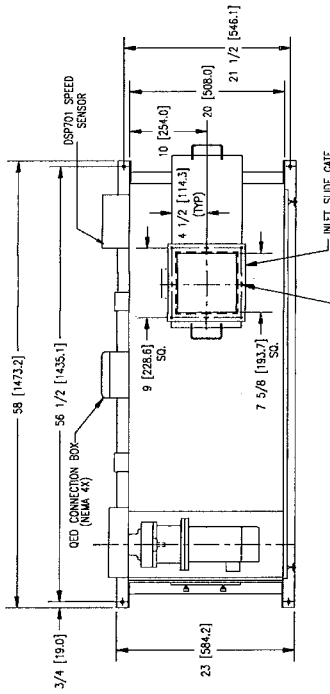

VIEW "A-A"

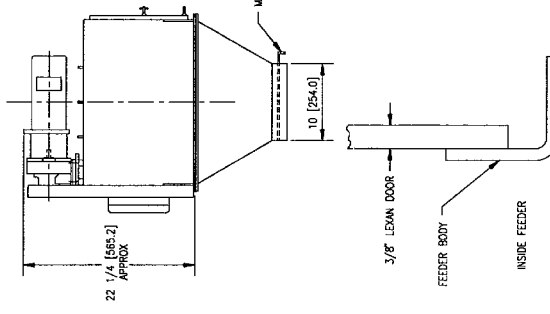

VIEW "C-C"

DRAWING F-001  
RF-2 REACTIVATION FURNACE

Revision 1  
April 2012

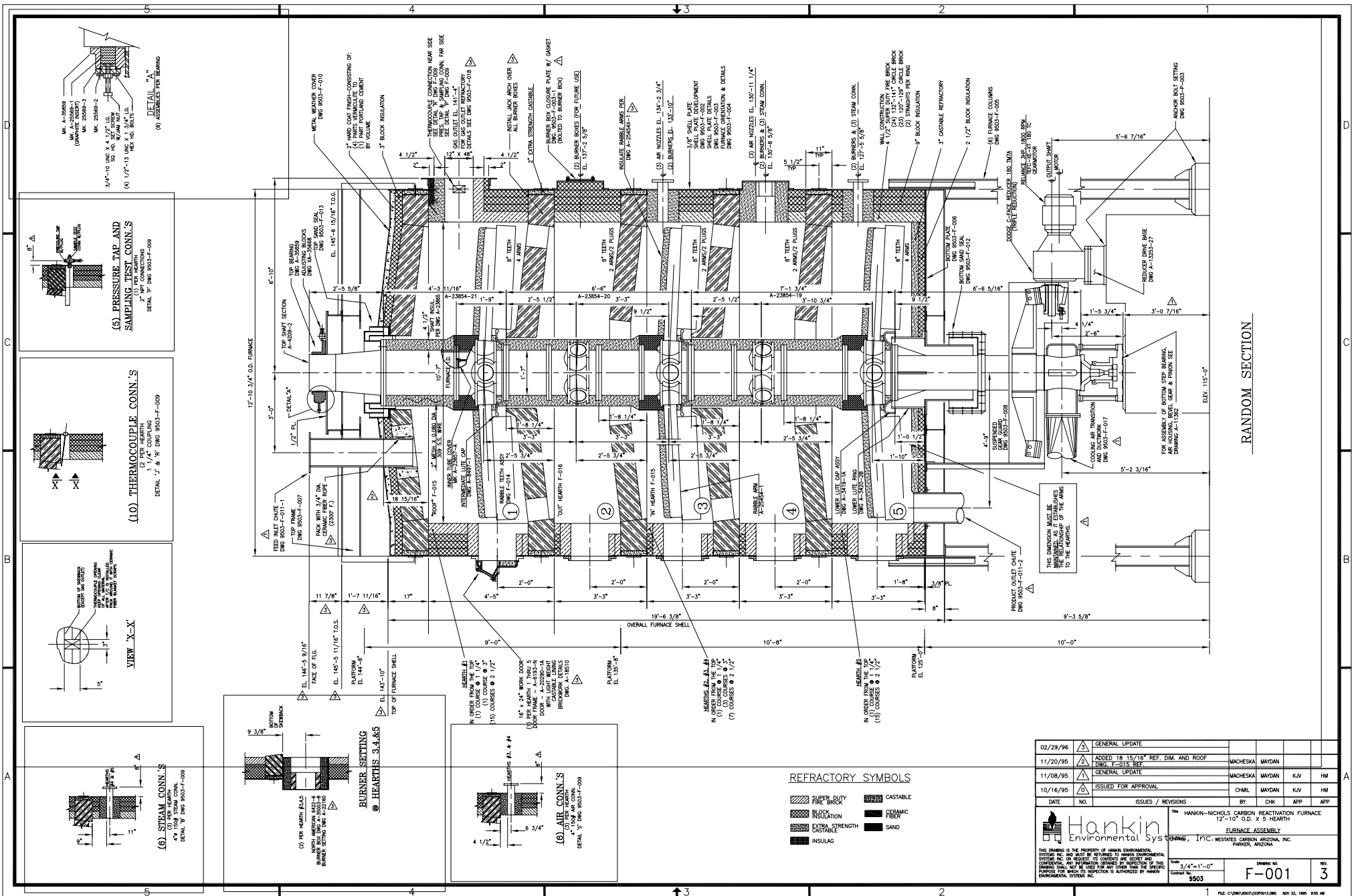

RANDOM SECTION

REFRACTORY SYMBOLS

- REFR. DUTY
- INSULATION
- CASTABLE
- CASTABLE
- CASTABLE
- INSULAG
- CASTABLE
- CERAMIC FIBER
- SAND

02/29/96	△ GENERAL UPDATE			
11/20/95	△ ADDED 18 15/16" REF. DIM. AND ROOF DWG. F-015 REF.	MACHESKA	MAYDAN	
11/08/95	△ GENERAL UPDATE	MACHESKA	MAYDAN	KJV HM
10/16/95	△ ISSUED FOR APPROVAL	CHMIL	MAYDAN	KJV HM
DATE	NO.	ISSUES / REVISIONS	BY	CHK APP APP
		THE HANKIN-NICHOLS CARBON REACTION FURNACE 12'-10" O.D. X 5' HEARTH FURNACE ASSEMBLY HANBIN, INC. WESTGATES, ARIZONA, INC. PARKER, ARIZONA		
THIS DRAWING IS THE PROPERTY OF HANBIN ENVIRONMENTAL SYSTEMS INC. AND MUST BE RETURNED TO HANBIN ENVIRONMENTAL SYSTEMS INC. ON REQUEST. NO COPIES OR REPRODUCTIONS OF THIS DRAWING SHALL BE MADE FOR ANY OTHER THAN THE SPECIFIC PURPOSE FOR WHICH THIS DRAWING IS AUTHORIZED BY HANBIN ENVIRONMENTAL SYSTEMS INC.		Scale: 3/4"=1'-0" Drawing No.: F-001 Rev: 3	DATE: 02/29/96 DRAWING NO.: F-001 REV: 3	

DRAWING P-007  
RF-2 AFTERBURNER

Revision 1  
April 2012

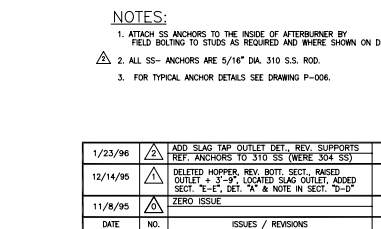
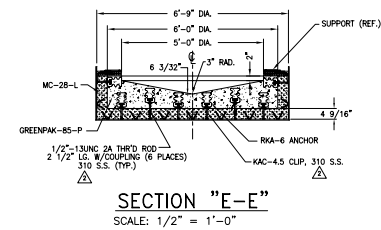
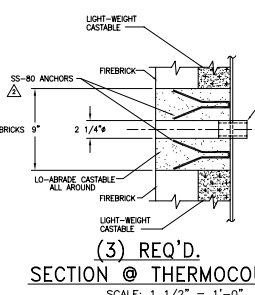
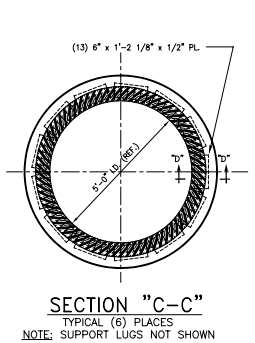
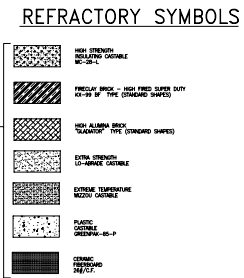
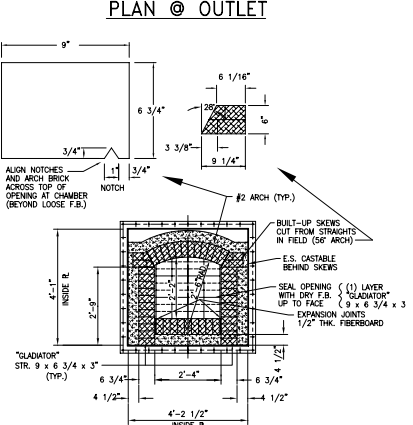
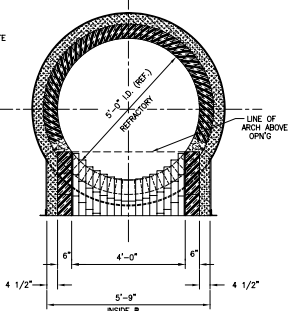
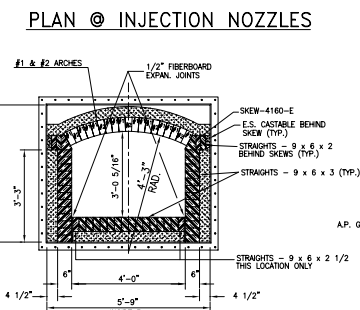
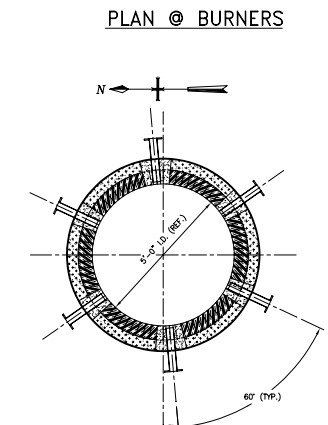
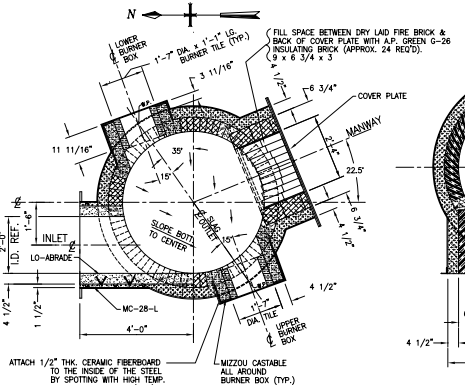
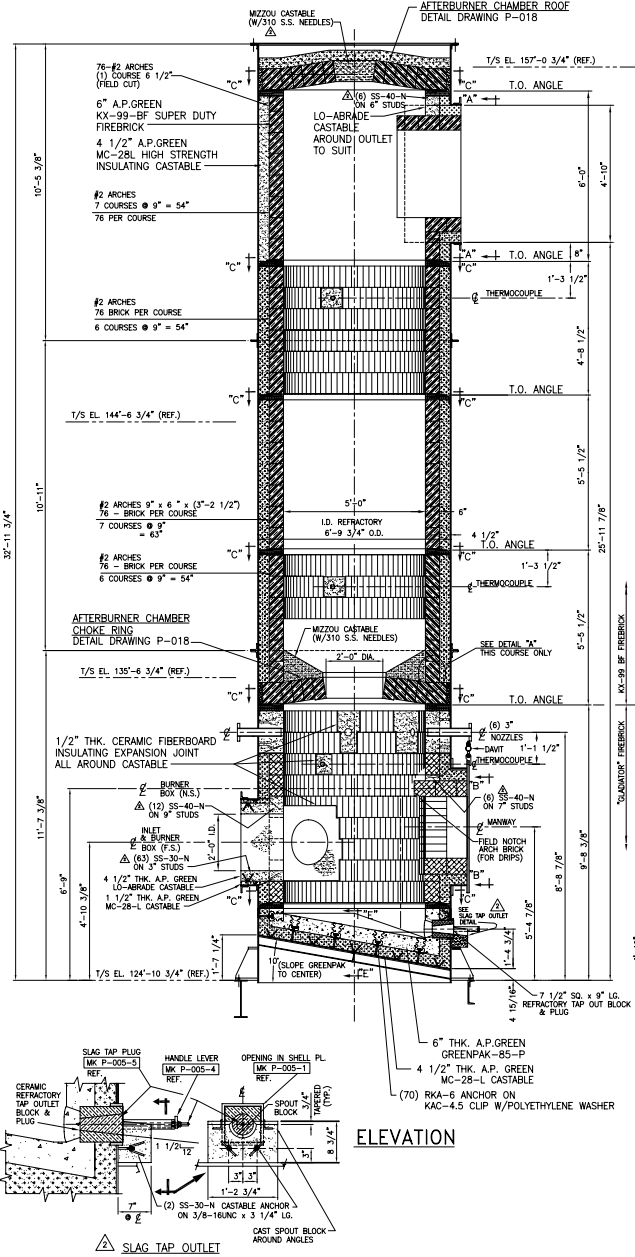

**NOTES:**

- ATTACH SS ANCHORS TO THE INSIDE OF AFTERBURNER BY FIELD BOLTING TO STUDS AS REQUIRED AND WHERE SHOWN ON DRAWINGS.
- ALL SS-ANCHORS ARE 5/16\"/>
- FOR TYPICAL ANCHOR DETAILS SEE DRAWING P-006.

1/23/96	ADD SLAG TAP OUTLET DET. REV. SUPPORTS REF. ANCHORS TO 310 SS (WERE 304 SS)					
12/14/95	DELETED HOPPER, REV. BOT. SECT., RAISED OUTLET + 3'-9\"/>					
11/8/95	ZERO ISSUE					
DATE	NO.	ISSUES / REVISIONS	GRS	JMM	KJV	HM
			BY	CHK	APP	APP

**Hankin Environmental Systems, Inc.**  
 HANKIN-NICHOLS CARBON REACTION SYSTEM  
 12'-10\"/>

Scale: 1/2" = 1'-0"  
 Drawing No: P-007  
 Rev: 2



DRAWING DJ95-539-1 & 2  
CGS VENTURI SCRUBBER/ABSORBER

Revision 1  
April 2012

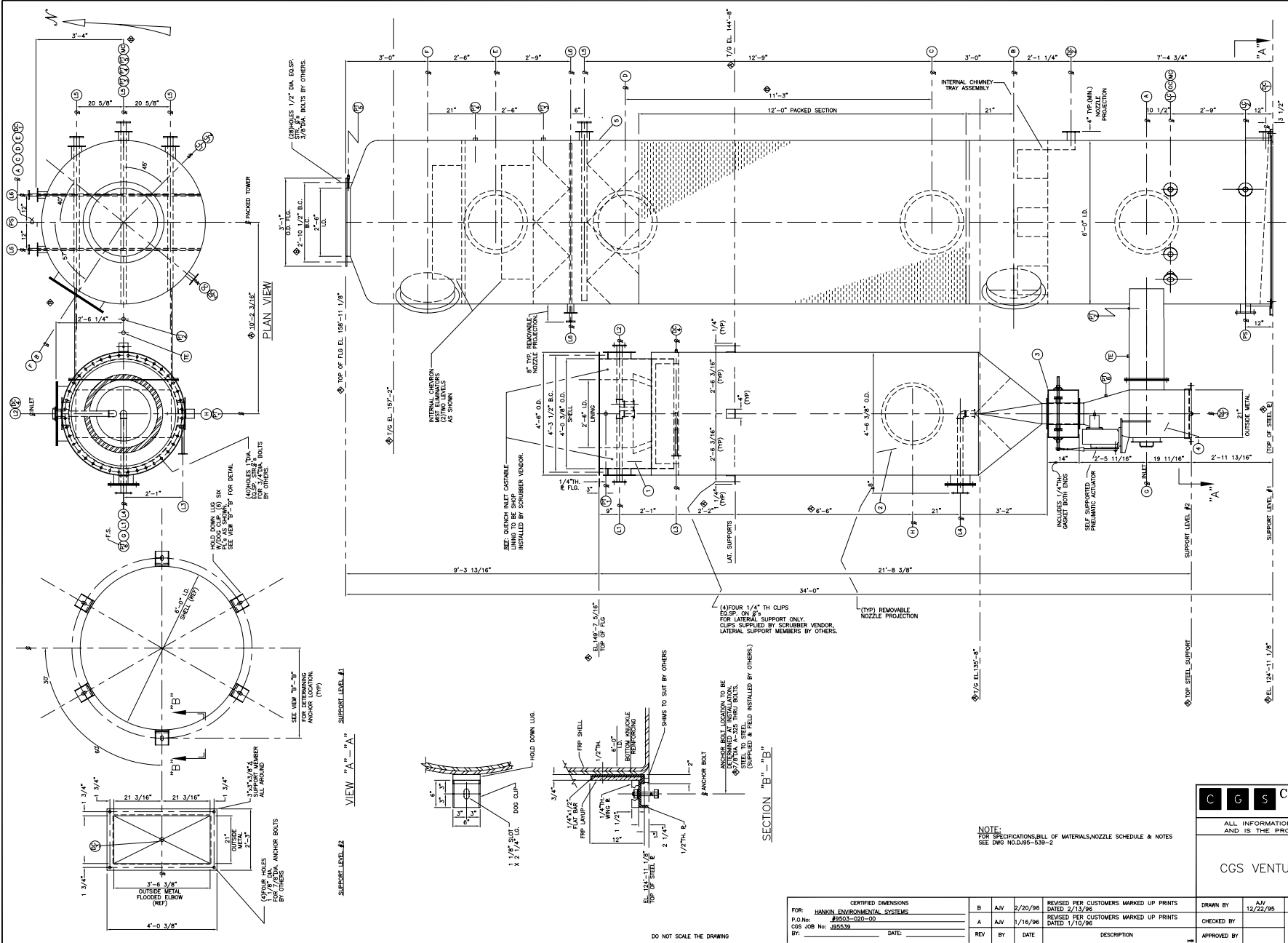

**ELEVATION**  
(NOT FOR TRUE ORIENTATION SEE PLAN)

**CGS CLEAN GAS SYSTEMS, INC.**  
RONKONKOMA, NY.

ALL INFORMATION ON THIS DRAWING IS CONFIDENTIAL AND IS THE PROPERTY OF CLEAN GAS SYSTEMS, INC.

ARRANGEMENT  
CGS VENTURI SCRUBBER/ABSORBER  
SIZE: 29/72

FOR:	CERTIFIED DIMENSIONS	REVISED PER CUSTOMERS MARKED UP PRINTS	DATE	DESCRIPTION
FOR: HANSON ENVIRONMENTAL SYSTEMS	B	A/V	2/20/96	REVISED PER CUSTOMERS MARKED UP PRINTS DATED 2/13/96
P.O. No: #2503-020-00	A	A/V	1/16/96	REVISED PER CUSTOMERS MARKED UP PRINTS DATED 1/10/96
COS JOB No: 493539	REV	BY	DATE	DESCRIPTION
DATE: _____				

DRAWN BY	CHECKED BY	APPROVED BY	SCALE	TOLERANCE	DRAWING NO.	REV
A/V	A/V		12/22/95	ANGULAR	DJ95-539-1	B

**SPECIFICATIONS**

**CONSTRUCTION MATERIAL**

ITEM ①: PRE-QUENCH INLET TO BE FABRICATED FROM 3/16"TH. MIN HASTELLOY-C276.  
 INTERIOR OF PRE-QUENCH INLET TO BE REFACTORY LINED WITH 9"TH. INSULATING  
 CASTABLE, SHOP INSTALLED AND AIR CURED.  
 LINING ANCHORING SYSTEMS TO BE S.S.TYPE 310 (V-TYPE ANCHORS).  
 PRE-QUENCH LIQUID INLET ① & ② SPRAY HEADERS TO BE HASTELLOY -C 276. W/HASTELLOY C SPRAY NOZZLES.  
 NOTE: ITEM ① PRE QUENCH INLET SECTION TO BE SUPPORTED BY OTHERS.  
 SEE NOTE 3.

ITEM ②: VENTURI INLET SECTION WITH LIQUID EXPANSION JOINT TO BE FABRICATED  
 FROM 3/16"TH. MIN. HASTELLOY-C 276.  
 LIQUID INLET ③ & ④ SPRAY HEADERS TO BE HASTELLOY-C 276.

ITEM ③ & ④: VENTURI THROAT AND FLOODED ELBOW SECTION TO BE FABRICATED  
 FROM 3/16"TH. HASTELLOY-C 276.

EXTERNAL REINFORCING, LIFTING LUGS, AND SUPPORT BRACKETS FOR THE ABOVE  
 ITEMS TO BE S.S TYP 18-8

EXTERNAL BOLTS & NUTS FOR THE ABOVE ITEMS TO BE S.S.TYPE 304.  
 GASKETS FOR THE ABOVE ITEMS TO BE 1/4" TH. NEOPRENE #40 DURO.

ITEM ⑤: PACKED TOWER SHELL TO BE FABRICATED FROM 3/4"TH. MIN FRP.

FABRICATION: HAND LAYUP PER NBS PS 15-69 AND /OR HAND LAYUP  
 PER ASTM D 4097-88. FILAMENT WOUND PER D 3299-88.

RESIN: DERAKANE 470  
 VEIL: NEXUS 10-15 MILS.

OUTSIDE COATING: UV INHIBITOR CELL COAT WHITE IN COLOR.

EXTERNAL BOLTS & NUTS: GALVANIZED C.S. W/TEFLON ENVELOPE EXCEPT AT HOLD DOWN LUGS USE

A-325 C.S. BOLTS (SUPPLIED BY OTHERS) WITH CORROSION RESISTANT FINISH (NOT NECESSARILY GALVANIZED.)

GASKETS: GORTEX ROPE.

EXTERNAL LIFTING AND HOLD DOWN LUGS: GALVANIZED C.S.

**NOTES:**

1. WELDING TO BE PER AWS. ALL SHELL BUTT WELDS TO BE MADE FROM (2)TWO SIDES (INSIDE & OUTSIDE). ALL CORNER JOINTS TO BE DOUBLE FILLETS.
2. UNIT DESIGN PRESSURE -70" W.G.
3. DESIGN LOADS BASED ON 100 MPH WIND/SEISMIC ZONE 3.  
 PACKED TOWER 6 LUGS W/ 6,800 LBS EACH  
 \* TOTAL PACKED TOWER EMERGENCY LOAD 16000#  
 VENTURI SCRUBBER 4 SUPPORTS W/ 1,650 LBS EACH  
 \*\* TOTAL VENTURI SCRUBBER OPERATING LOAD 3200#  
 PRE-QUENCH INLET ITEM ① DEAD LOAD 2,500LBS (INDEPENDENTLY SUPPORTED BY OTHERS)
4. (1)ONE UNIT REQ'D. AS SHOWN.

\*: TOTAL EMERGENCY LOAD INCLUDES STANDING DEAD LOAD  
 PLUS PACKED TOWER FILLED WITH WATER TO BOTTOM OF GAS INLET.

\*\*: TOTAL OPERATING LOAD INCLUDES STANDING DEAD LOAD  
 PLUS 12" OF WATER IN BOTTOM OF FLOODED ELBOW.

**BILL OF MATERIAL**

ITEM	QTY.	DESCRIPTION	REMARKS
1	1	SIZE: 29 PRE QUENCH INLET	SEE SPEC'S.
2	1	VENTURI INLET SECTION WITH LIQUID EXPANSION JOINT	SEE SPEC'S.
3	1	VENTURI THROAT(DOOR THROAT W/ PNEUMATIC ACTUATOR.)	SEE SPEC'S.
4	1	FLOODED ELBOW SECTION.	SEE SPEC'S.
5	1	PACKED TOWER ( 6'-0" DIA)	SEE SPEC'S.

**NOZZLE SCHEDULE**

A	1	24" BOLTED TYPE INSPECTION DOOR	
B	1	24" BOLTED TYPE INSPECTION DOOR	
C	1	24" BOLTED TYPE INSPECTION DOOR	
D	1	24" BOLTED TYPE INSPECTION DOOR	
E	1	24" BOLTED TYPE INSPECTION DOOR	
F	1	24" BOLTED TYPE INSPECTION DOOR	
G	1	12" BOLTED TYPE INSPECTION DOOR	
H	1	24" BOLTED TYPE INSPECTION DOOR	
L1	1	LIQUID INLET-2"SCH 40 PIPE	SEE NOTE: * AND **
L2	1	LIQUID INLET-3"SCH 40 PIPE	SEE NOTE: * AND **
L3	1	LIQUID INLET-3/4"SCH 40 PIPE	SEE NOTE: *
L4	1	LIQUID INLET-2"SCH 40 PIPE	SEE NOTE: * AND **
L5	3	LIQUID INLET-1 1/2" FRP PIPE W/POLYPR. SPRAY NOZZLES.	SEE NOTE: * AND **
L6	2	LIQUID INLET-1/2"FRP PIPE W/POLYPR. SPRAY NOZZLES.	SEE NOTE: * AND **
PS	1	4"DIA PUMP SUCTION.	SEE NOTE: *
DC	1	2" DRAIN CONNECTION.	SEE NOTE: *
DC	1	3" DRAIN CONNECTION.	SEE NOTE: *
DC	1	1"DIA HALF CPL'G WITH PLUG.	NPT
DC	1	1/2"DIA HALF CPL'G. WITH PLUG.	NPT
LC	1	3"DIA STILLING WELL CONNECTION.	SEE NOTE: *
LC	1	3"DIA STILLING WELL CONNECTION.	SEE NOTE: *
OC	1	2"DIA OVERFLOW CONNECTION.	SEE NOTE: *
MC	1	2"DIA MAKEUP CONNECTION.	SEE NOTE: *
PT	1	1" HALF CPL'G. W/PLUG - PRESS. TAP.	NPT
PT	1	1/2" HALF CPL'G. W/PLUG - PRESS. TAP.	NPT
PT	1	1/2" HALF CPL'G. W/PLUG - PRESS. TAP.	NPT
PT	1	1/2" HALF CPL'G. W/PLUG - PRESS. TAP.	NPT
PT	1	1/2" HALF CPL'G. W/PLUG - PRESS. TAP.	NPT
PT	1	1/2" HALF CPL'G. W/PLUG - PRESS. TAP.	NPT
TE	1	1" HALF CPL'G. W/PLUG - TEMP. TAP.	NPT

NOTE \*: NOZZLES SPECIFIED ARE PROVIDED WITH PLATE FLANGES  
 DRILLED TO MATCH ANSI 150# HOLES TO STRADDLE C's.

NOTE \*\*: LIQUID INLETS SPECIFIED ARE REMOVABLE TYPE.

REF. DWGS.:  
 GENERAL ARRANGEMENT DJ95-539-1



**CLEAN GAS SYSTEMS, INC.**

SPECIFICATIONS, NOZZLE SCHEDULE & NOTES  
 CGS VENTURI SCRUBBER/ABSORBER  
 SIZE: 29/72

FOR: HANKIN ENVIORNMENTAL SYSTEMS  
 P.O. No. 9503-020-00  
 CGS JOB No. J95539

REV.	BY	DATE	DESCRIPTION
C	JFB	3/4/96	ADDED LIQUID TEMP.(RECIRC) TO LIQUID DATA.
B	JFB	2/8/96	REVISED WHERE INDICATED BY
A	JFB	1/16/96	REVISED PER CUSTOMERS MARKED UP PRINT DATED 1/10/96

DRN BY: JFB  
 DATE: DWG. No.: DJ95-539-2

REV. C

DRAWING DJ95-540-1  
CGS WET ELECTROSTATIC PRECIPITATOR

Revision 1  
April 2012

(32) HOLES, 1/2" DIA. EQ. SP. STR. CENTERLINES

(1) ONE 10" DIA. NOZZLE FOR HIGH VOLTAGE CONNECTION COMPLETE WITH PLATE FLG. DRILLED TO MATCH ANSI 150#. HOLES TO STRADDLE 8'S. SEE PLAN VIEW FOR ORIENTATION.

CONNECTED POWER: 20 KVA  
VOLTAGE: 480/1/60

NOTE: \* NOZZLES SPECIFIED ARE PROVIDED WITH FRP PLATE FLANGES. DRILLING TO MATCH ANSI 150#. HOLES TO STRADDLE CENTERLINES.

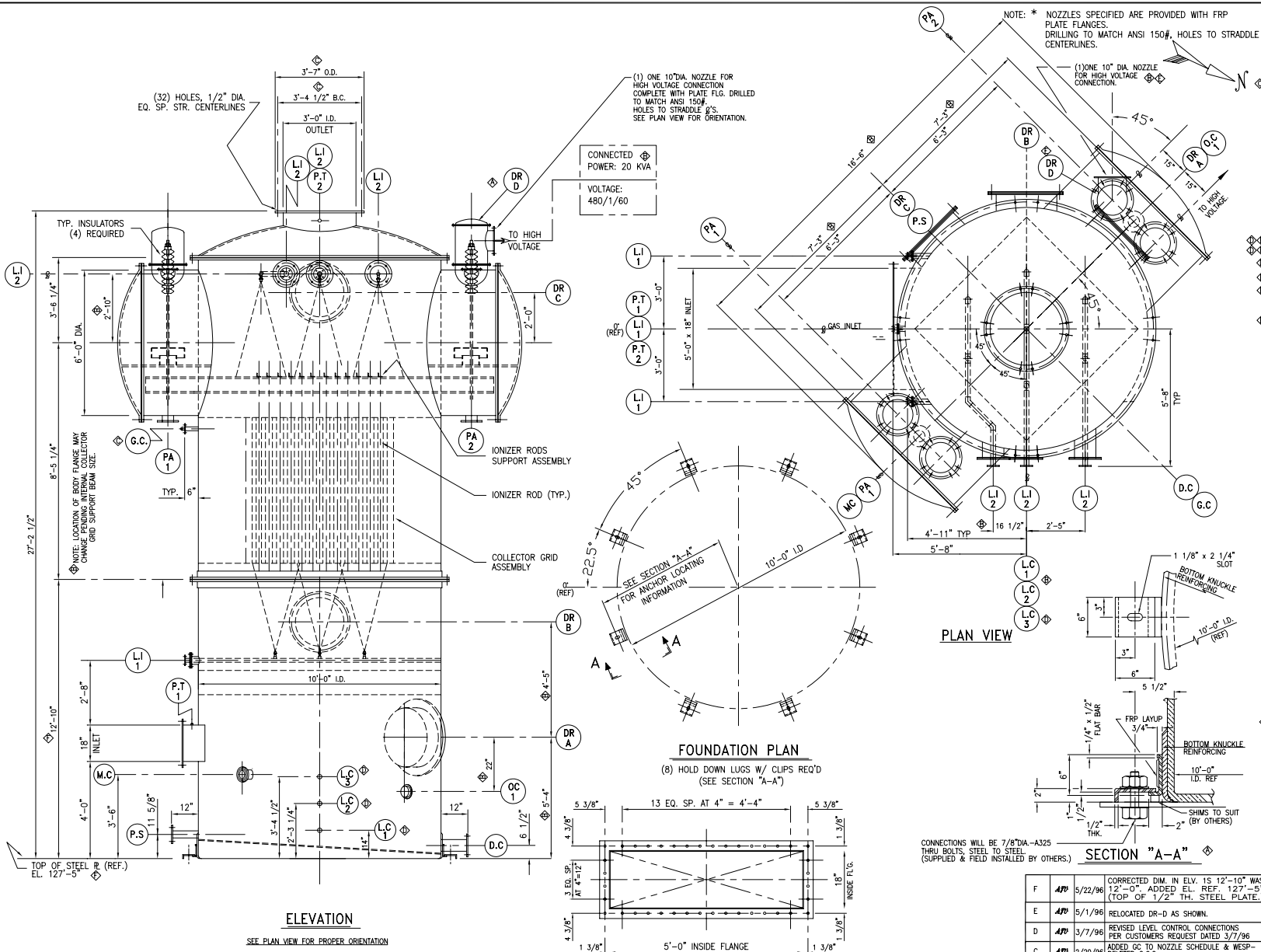

**NOZZLES SCHEDULE**

ITEM	QTY.	DESCRIPTION	REMARKS
D.C	1	4" DIA. DRAIN CONN. ( FLANGED )	SEE NOTE: *
O.C	1	3" DIA. OVERFLOW CONN. ( FLANGED )	SEE NOTE: *
G.C.	1	3" DIA. COLLECTOR GRID EXTERNAL GROUND CONN.(FLANGED)	SEE NOTE: *
P.S	1	4" DIA. PUMP SUCTION CONN. ( FLANGED )	SEE NOTE: *
LI 1	3	LIQUID INLET 1" FLANGED CONN.(REMOVABLE)	SEE NOTE: *
LI 2	3	LIQUID INLET 2" FLANGED CONN.(REMOVABLE)	SEE NOTE: *
DR A	1	24" DIA. BOLTED TYPE ACCESS DOOR	
DR B	1	24" DIA. BOLTED TYPE ACCESS DOOR	
DR C	1	24" DIA. BOLTED TYPE ACCESS DOOR	
DR D	1	16" DIA. BOLTED TYPE DOOR	
PT 1	1	1/2" FULL COUPLING WITH PLUG	PRESSURE TAP
PT 2	1	1/2" FULL COUPLING WITH PLUG	PRESSURE TAP
LC 1	1		LEVEL CONTROL CONNECTIONS (NPT)
LC 2	1	1 1/2" FULL COUPLING	
LC 3	1		
MC	1	2"DIA. MAKE-UP CONN.	SEE NOTE *
PA 1	1	2"DIA. PURGE AIR HEATER CONN.	
PA 2	1	2"DIA. PURGE AIR HEATER CONN.	SEE NOTE *

**SPECIFICATIONS:**

**CONSTRUCTION MATERIAL:**  
HOUSING TO BE FABRICATED FROM 0.66" THK. MIN. FRP, EXCEPT BOTTOM FLOOR TO BE 2 3/4" THK. ( 3/8" FRP, 2" Balsa, 3/8" FRP ).  
LIQUID SPRAY HEADERS TO BE FRP PIPE WITH HASTELLOY-C NOZZLES AT LI 1 AND POLYPROPYLENE AT LI 2.  
FABRICATIONS: HAND LAYUP PER NBS PS 15-69 AND/OR HAND LAYUP PER ASTM D 4097-88.  
FILAMENT WOUND PER ASTM D 3299-88.  
RESIN: DERWANE 470  
VEIL: NEXUS 10-15 MILS  
OUTSIDE COATING: UV INHIBITOR GELL COAT WHITE IN COLOR  
EXTERNAL BOLTS AND NUTS: GALVANIZED C.S. W/TEFLON ENVELOPES  
GASKETS: CORTEX ROPE  
EXTERNAL LIFTING LUGS AND HOLD DOWN LUGS: GALVANIZED C.S.  
INTERNAL HIGH VOLTAGE COMPONENTS INCLUDING HEXAGONAL TUBE GRID ASSEMBLY TO BE #10 GA. MIN. ALKIN OR "EQUAL"  
INTERNAL BOLTS AND NUTS TO BE ALKIN OR HASTELLOY-C.

**NOTES:**

- UNIT DESIG PRESS -70" W.G.
- DESIGN LOADS BASED ON 100 MPH WIND/SEISMIC ZONE 3.  
CG-WESP 8 LUGS WITH 2,800 LBS. EACH.
- TOTAL WESP EMERGENCY LOAD IS 41,000#
- INTERNAL HIGH VOLTAGE COMPONENTS WILL BE SHIPPED LOOSE FOR FIELD INSTALLATION AND ASSEMBLY.
- (1)ONE UNIT REQ'D AS SHOWN AND NOTED.
- TOTAL EMERGENCY LOAD INCLUDES STANDING DEAD LOAD PLUS WESP FILLED WITH WATER TO BOTTOM OF GAS INLET.

FOR: HAWKIN ENVIRONMENTAL SYSTEMS, INC.  
WESTATES CARBON, INC.  
PARKER, ARIZONA PROJECT.

**CGS CLEAN GAS SYSTEMS, INC.**  
RONKONKOMA, NY.

ALL INFORMATION ON THIS DRAWING IS CONFIDENTIAL AND IS THE PROPERTY OF CLEAN GAS SYSTEMS, INC.

**CGS WET ELECTROSTATIC PRECIPITATOR**  
SIZE: 36-120-C TYPE: CG-WESP HC

REV	BY	DATE	DESCRIPTION
F	470	5/22/96	CORRECTED DIM IN ELV. IS 12'-10" WAS 12'-0". ADDED EL. REF. 127'-5" (TOP OF 1/2" TH. STEEL PLATE.)
E	470	5/1/96	RELOCATED DR-D AS SHOWN.
D	470	3/7/96	REVISED LEVEL CONTROL CONNECTIONS PER CUSTOMERS REQUEST DATED 3/7/96
C	470	2/20/96	ADDED GC TO NOZZLE SCHEDULE & WESP-DELETED O.C.2
B	470	1/24/96	REVISIONS PER CUSTOMERS MARKED-UP DWG'S DATED 1/22/96 & AS INDICATED BY
A	470	1/16/96	REVISIONS PER CUSTOMERS MARKED-UP DWG'S DATED 1/10/96

CERTIFIED DIMENSIONS  
FOR: HAWKIN ENVIRONMENTAL SYSTEMS, INC.  
P.O. No: 9503-021-00  
CGS JOB No: 95560  
DATE:

DRAWN BY	R.K.	SCALE: N.T.S.	DRAWING NO.	REV
CHECKED BY	12.19.95	TOLERANCE FRACTIONS ANGULAR	DJ95-540-1	F
APPROVED BY				

DRAWING C25923F1  
INDUCED DRAFT FAN

Revision 1  
April 2012

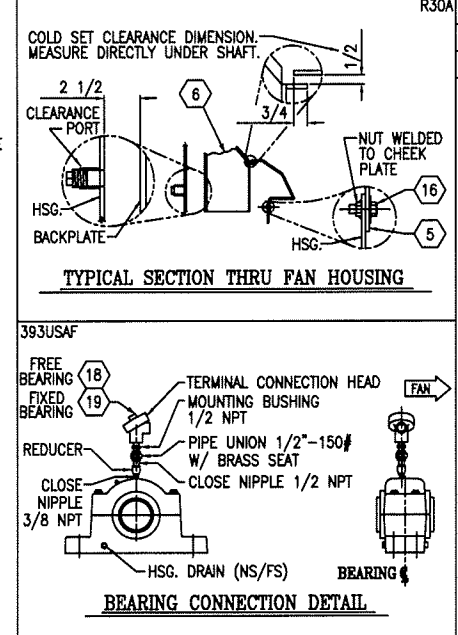
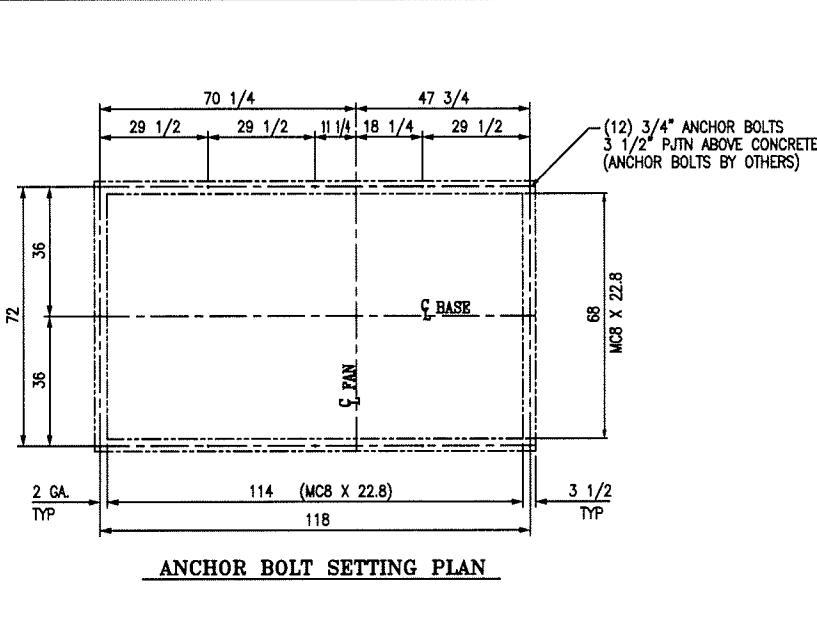
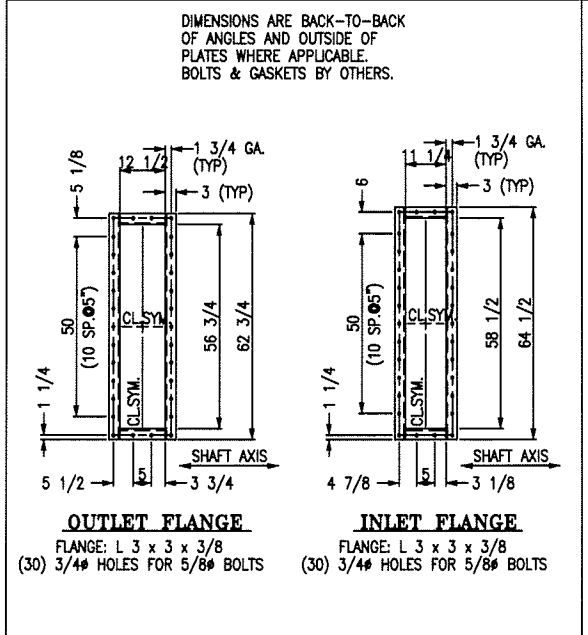

BEARING LUBRICATION REQUIREMENTS	
TYPE:	STATIC
GREASE:	MOBILITH SHC 220

CUST FIND #	PCS TO SHIP	SHOP ASSY PCS	DESCRIPTION	
	1		FAN ASSEMBLY	
1	1		HOUSING BASE SECTION	3/8" THK 317L
2	1		IMPELLER REMOVAL SECTION	
3	1		DISCHARGE SECTION	
4			***** NOT USED *****	
5	1		INLET CONE	
6	1		IMPELLER: 662, R30A, 20%, SW, CCW	66 1/4" DIA. FERR 255 AVESTA 2206
7	1		PEDESTAL ASSEMBLY	A36
8	1		FIXED BRG: SKF-SAF 225	3 15/16 DIA. SPHERICAL ROLLER
9	1		FREE BRG: SKF-SAF 1500	2 15/16 DIA. DOUBLE ROW BALL
10	1	LOT	BEARING MOUNTING HARDWARE	A307 GRA
11	1		DRIVE COUPLING: HOLSET PM12	(SEE NOTE #5)
12	1		COUPLING GUARD	A36
13	2		SHAFT SEAL ASSEMBLY	
14	1		GASKET 1/8 x 3	FIBERGLASS
15	1	LOT	ASSEMBLY HARDWARE (HHBOLT 5/8" X 1 1/2" W/ NUT)	316
16	1	LOT	INLET CONE ASSY HARDWARE (HUB: 3/8" X 1 1/2" W/ NUT) (EXTN. HX. FLAT WASHER)	316
17	7		SPLICE BAR	317L
18	1		THERMOCOUPLE: PYCO "J" SPRING-LOADED, SINGLE ELEMENT	
			w/ ENCLOSURE & MTG HARDWARE (P/N 02-3046-13-4.4)	
19	1		THERMOCOUPLE: PYCO "J" SPRING-LOADED, SINGLE ELEMENT	
			w/ ENCLOSURE & MTG HARDWARE (P/N 02-3046-13-4.8)	
20	1		MOTOR: SIEMENS FRAME: 445T TYPE: RGZSD	
			BHP: 150 RPM: 1800 S.F.: 1.0 INP: 460V/3PH/60HZ	
21	1	LOT	MOTOR ASSEMBLY HARDWARE	A307 GRA

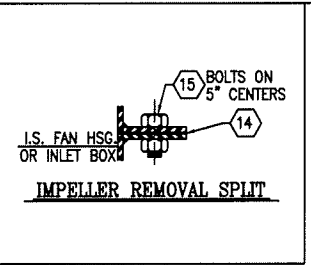
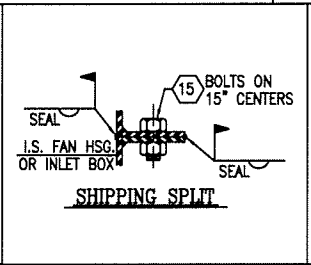
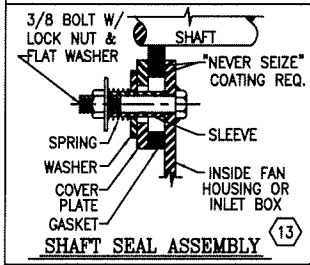

- GENERAL NOTES:**
- ONE FAN REQ'D - CCW ROTATION
  - FAN HOUSING IS NOT DESIGNED TO SUPPORT ANY EXTERNAL LOADS.
  - CUSTOMER IS TO PROVIDE EXPANSION JOINTS AT INLET AND OUTLET TO RELIEVE EXPANSION STRESSES AND VIBRATION.
  - DOWEL BEARINGS AND PEDESTALS TOGETHER AFTER THEY ARE ALIGNED AND BOLTED TOGETHER IN THE FIELD. (DOWELS PROVIDED BY OTHERS.)
  - COUPLING INFORMATION:  
IMPELLER HALF BORE: 3.8735/3.8725# KEYWAY: 1 X 1/2  
BORED: BY BARRON MOUNTED: BY BARRON  
DRIVE HALF BORE: 3.3735/3.3725# KEYWAY: 7/8 X 7/16  
BORED: BY BARRON MOUNTED: BY BARRON
  - ROTATING ASSEMBLY WEIGHT: 1130 LBS.
  - HOUSING STIFFENERS NOT SHOWN FOR CLARITY. (STIFF. MAT'L: 317L)
  - WELD ALL STIFFENERS CROSSING SHIPPING SPLITS TOG. AT FIELD INSTALLATION.
  - SEE BARRON OWNERS MANUAL FOR INSTALLATION & OPERATION INSTRUCTIONS.
  - SHOP TO CHECK IMPELLER TO PREVENT MOVEMENT DURING SHIPMENT. CUSTOMER MUST REMOVE CHOCKS PRIOR TO START UP.
  - THIS FAN IS EQUIPPED WITH AN INLET DAMPER SEE DWG. C25923D1 FOR DETAILS.

- PAINTING REQUIREMENTS:**
- BASE / GUARDS  
COATED SURFACES: FAN BASE - EXTERIOR ONLY  
BALANCE - ALL SURFACES
- SURFACE PREP: SSPC-SP7  
PRIMER: SOUTHERN COATINGS #1-4336(GRAY)  
NO. COATS: 1 THICKNESS PER COAT: 1-2 MILS D.F.T.
- PORTIONS OF SHAFT W/O STN. STL. COVERS  
COATED SURFACES: ALL  
SURFACE PREP: SSPC-SP7  
PRIMER: SOUTHERN COATINGS #1-1379(RED OXIDE)  
NO. COATS: 1 THICKNESS PER COAT: 1-2 MILS D.F.T.
- VARIABLE SPEED FAN  
VFD BY WESTATES CARBON

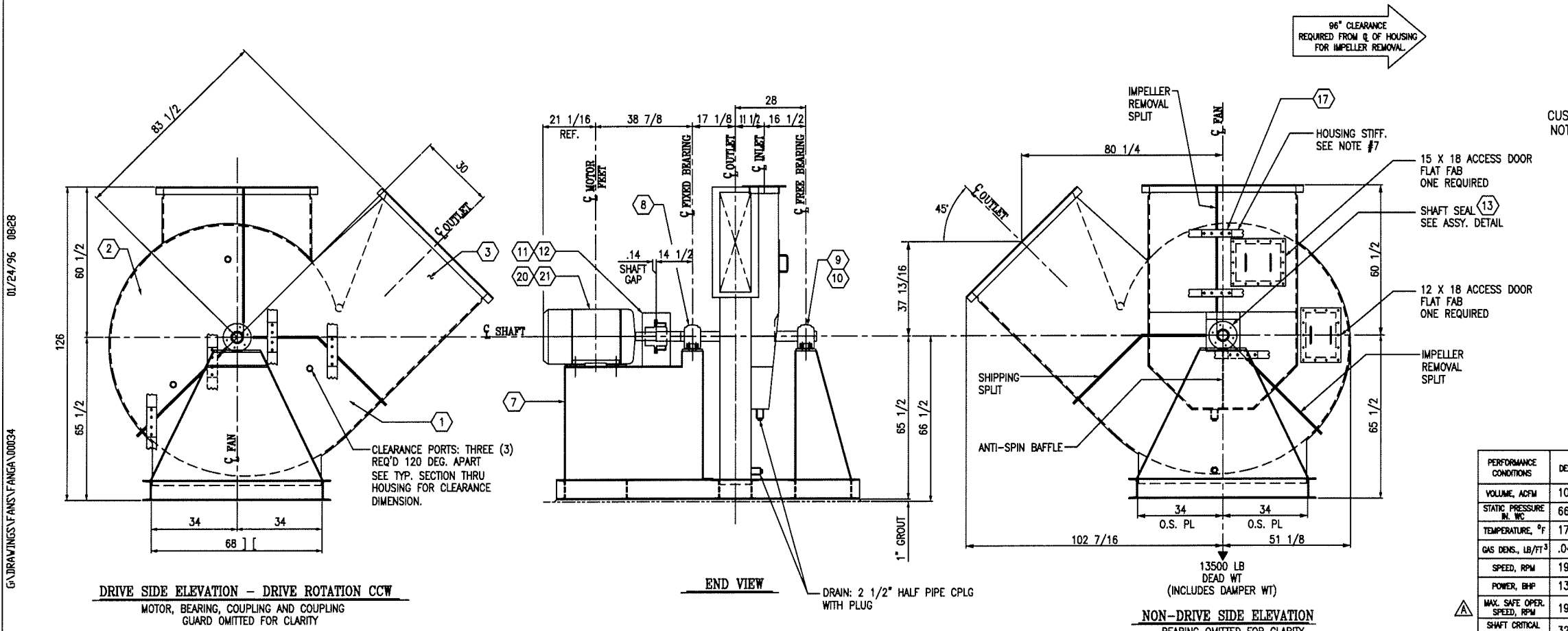

PERFORMANCE CONDITIONS	DES	HIGH	LOW
VOLUME, ACFM	10104	8420	6315
STATIC PRESSURE IN. WC	66.0	53.0	41.0
TEMPERATURE, °F	174	174	174
GAS DENS., LB/FT <sup>3</sup>	.0440	.0458	.0464
SPEED, RPM	1980	1740	1510
POWER, BHP	136	91	53
MAX. SAFE OPER. SPEED, RPM	1980	MAX. SAFE OPER. TEMP. °F	200
SHAFT CRITICAL SPEED, RPM	3260	IMPELLER WR <sup>2</sup> LB FT <sup>2</sup>	3166

**BARRON INDUSTRIES INC.**  
LEEDS, AL PHONE (206) 699-2101

CUST: HANKIN ENVIRONMENTAL  
SOMERVILLE, NEW JERSEY

USER: WESTATES CARBON ARIZONA  
PARKER, ARIZONA

APPLIC: SCRUBBER INDUCED DRAFT FAN TAG NO. B-15

EQUIP: 662/662 R30A SI(20.0%)SW ARRGT #7  
FAN GENERAL ARRANGEMENT

BY: MBB DATE: 2/13/96	BY: MBB DATE: 1/18/96	BY: MBB DATE: 1/19/96
CHK: DSB DATE: 2/13/96	CHK: DW DATE: 1/19/96	CHK: DW DATE: 1/19/96
REV: 1	REV: 1	REV: 1

THIS DRAWING IS THE PROPERTY OF BARRON INDUSTRIES AND IS LOANED ON THE CONDITION THAT IT SHALL NOT BE MADE PUBLIC, COPIED OR REPRODUCED IN WHOLE OR IN PART UNLESS AUTHORIZED BY BARRON INDUSTRIES.

EQ.#: P.O.: 9503-019-00  
DWG. No. C25923F1

GENERAL REVISION PER CUSTOMER APPROVAL

SHT. 1 OF 1 REV. A

DRAWING D95-75-S1-1  
DUAL WALL STACK & DETAILS

Revision 1  
April 2012



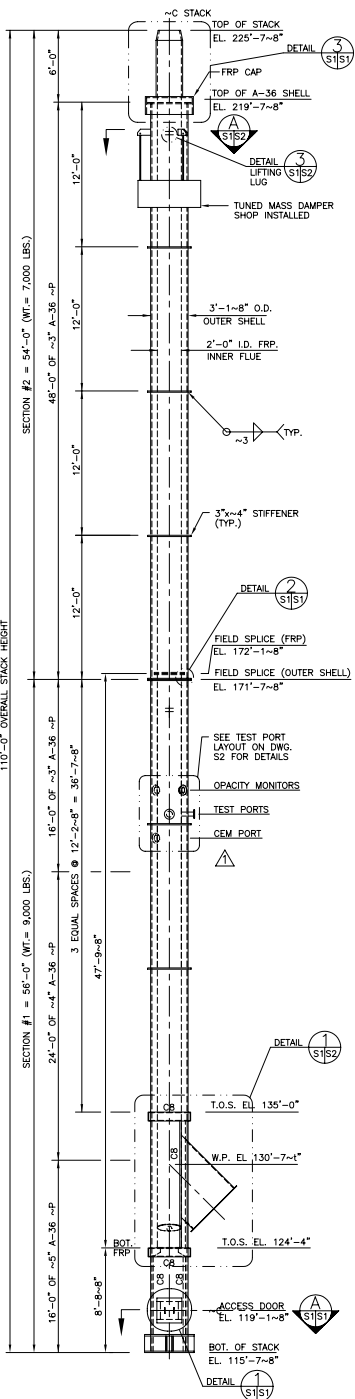

**STACK ELEVATION**  
SCALE: ~3"=1'-0"

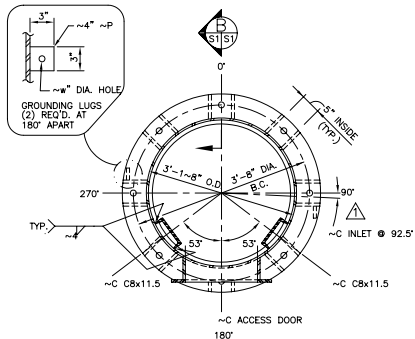

**SECTION A**  
SCALE: ~W"=1'-0"

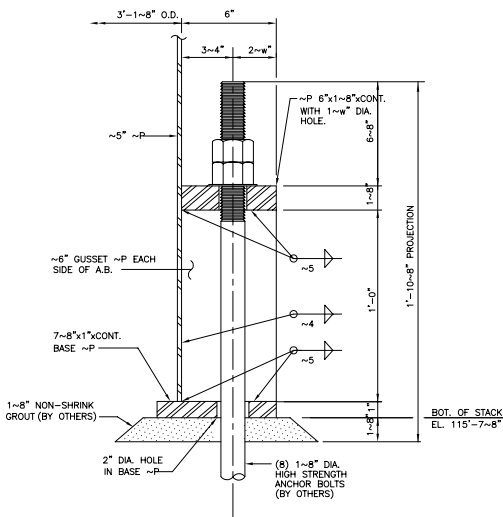

**SECTION B**  
SCALE: 3"=1'-0"

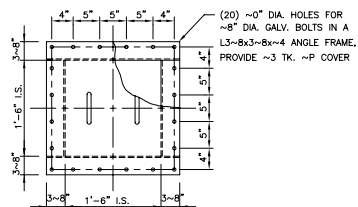

**DETAIL 1**  
SCALE: 1"=1'-0"

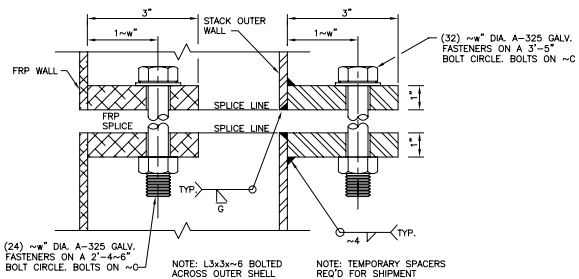

**FIELD SPICE DETAIL 2**  
SCALE: N.T.S.

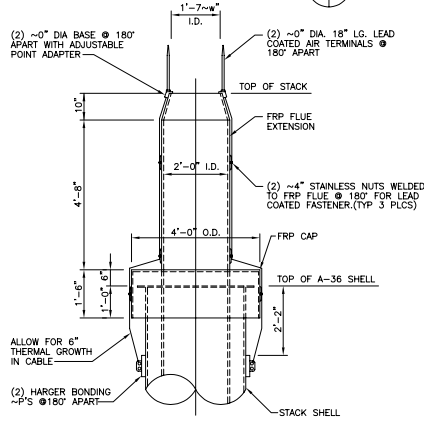

**DETAIL 3**  
SCALE: ~8"=1'-0"

**GENERAL NOTES**

- MATERIALS**  
A. SHELL PLATES AND ALL EXTERNAL COMPONENT PARTS SUCH AS STIFFENERS, LIFTING LUGS AND BRACES SHALL CONFORM TO ASTM A-36 UNLESS NOTED OTHERWISE.  
B. ALL FLUE MATERIAL INCLUDING TEST PORTS, CAP, INLET AND DRAIN SHALL BE FROM DEKARKE 510 FR. CAP, FALSE BOTTOM, INLET AND FLUE SHALL BE ~75% TK.
- FABRICATION** - ALL WORK SHALL BE FABRICATED IN ACCORDANCE WITH AISC "SPECIFICATIONS FOR STRUCTURAL STEEL BUILDINGS", LATEST EDITION. WELDS SHALL BE MADE ONLY BY WELDING OPERATORS WHO HAVE BEEN PREVIOUSLY QUALIFIED BY TEST AS PRESCRIBED IN THE AISC "STRUCTURAL WELDING CODE", OR BY THE ASME CODE, TO PERFORM THE TYPE OF WORK REQUIRED. ALL BUTT WELDS SHALL BE PRE-QUALIFIED, FULL PENETRATION WELDS AND SHALL DEVELOP THE FULL STRENGTH OF THE SECTION. SHELL GIRTH AND VERTICAL SEAMS SHALL BE COMPLETE PENETRATION BUTT GROOVE WELD TYPE AND TOTALLY WELDED EITHER AUTOMATICALLY OR SEMI-AUTOMATICALLY BY THE SUBMERGED ARC WELDING PROCESS. ELECTRODES SHALL CONFORM TO THE AWS CODE AND SHALL BE EQUIVALENT TO THE BASE METAL IN STRENGTH, CORROSION RESISTANT AND WEATHERED APPEARANCE.
- TOLERANCES** - WALL PLATES SHALL BE FABRICATED IN ACCORDANCE WITH THE FOLLOWING TOLERANCES:  
A. MAXIMUM DEVIATION OF BASE RING FROM CENTERLINE OF STACK - 3/16" FROM PLUMB AND OVERALL STRAIGHTNESS OF THE STACK SUCH THAT ERECTION OF THE STACK CAN BE PLUMBED TO WITHIN A MAXIMUM DEVIATION OF 1" PER 100' OF HEIGHT.  
B. MAXIMUM OUT-OF-ROUNDESS OF ANY SECTION - DIFFERENCE BETWEEN MINIMUM AND MAXIMUM DIAMETER - LESS THAN 1% OF NORMAL DIAMETER.  
C. MAXIMUM MISALIGNMENT OF PLATES AT ANY JOINT SHALL NOT EXCEED 25% OF NORMAL THICKNESS OR 1/8", WHICHEVER IS LESS.  
D. ADJOINING PLATE SECTIONS SHALL BE PAIRED FOR FULL 100% DEVELOPMENT.  
E. PEAKING OF VERTICAL JOINTS SHALL NOT EXCEED 1/4" AS MEASURED FROM THE TRUE RADIUS OF THE STACK.  
F. STRUCTURAL PLATES ARE TO BE PURCHASED OF SUFFICIENT LENGTH TO ALLOW FOR ONLY ONE VERTICAL SEAM PER GIRTH. VERTICAL SEAMS ON ADJACENT SECTIONS WILL BE OFFSET BY 90". IN SPECIAL CASES, A MAXIMUM OF TWO VERTICAL SEAMS WILL BE OFFSET AT LEAST 90". ALL APPURTENANCES, INCLUDING PLATFORMS AND LADDERS, WILL BE SHOP ATTACHED TO STACK TO ENSURE GOOD FIT.
- INSPECTION AND TESTING** - MATERIAL TEST REPORTS FOR ALL MATERIAL UTILIZED FOR MAJOR COMPONENTS SHALL BE SUBMITTED TO WARREN, MTR'S TO BE REQUESTED WHEN MATERIAL IS ORDERED AND FORWARDED TO WARREN IMMEDIATELY UPON RECEIPT.
- SURFACE PREPARATION**  
A. ALL SHARP PROJECTIONS SHALL BE GROUND SMOOTH.  
B. ALL WELD FLUX AND SPATTER SHALL BE REMOVED BY POWER TOOL CLEANING.
- PAINTING SPECIFICATION** - EXTERIOR & INTERIOR SURFACE TO BE SANDBLASTED PER SSPC-SP10 AND APPLY PRIMER COAT OF CARBO ZINC 11 INORGANIC ZINC AT 3.5 MILS DFT. TOP COAT WITH TWO COATS OF CARBOLINE 1248 SILICONE ACRYLIC AT 1.0 TO 1.5 MILS DFT EACH. TOTAL FILM THICKNESS TO BE 6 TO 7 MILS DFT. COLOR TO BE SELECTED.
- LOADING AND SHIPPING** - STACKS WILL BE LOADED AND SECURED ON TRUCKS SUCH THAT PLATES ARE NOT DEFORMED AND PAINT SYSTEM IS NOT COMPROMISED. STACK LOADS ARE TO BE DISTRIBUTED OVER LARGE AREAS. POINT LOADS ON PLATES ARE TO BE AVOIDED. TIMBERS USED TO SECURE LOADS ARE TO BE PLACED LONGITUDINALLY, SPANNING AT LEAST TWO STIFFENERS. ERECTOR TO REMOVE ALL TEMPORARY SPACERS AND BRACES BEFORE COMPLETING ERECTION.

**FOUNDATION DESIGN LOADS**

DEAD LOAD OF STACK	15 KIPS
WIND SHEAR AT BASE OF STACK	6 KIPS
WIND MOMENT AT BASE OF STACK	350 KIP-FT.
WIND CODE:	ASCE 7-93
WIND SPEED	100 MPH EXP. B
IMPORTANCE FACTOR	1.0
SEISMIC LOADS DOES NOT CONTROL	

**CERTIFIED FOR CONSTRUCTION**

WESTATES CARBON HANKIN ENVIRONMENTAL REF.# 9503-025	
PARKER	ARIZONA
DUAL WALL STACK & DETAILS	
WARREN ENVIRONMENT, INC. GEORGIA	
ATLANTA	

DESIGN	MADE RSS	CHKD. SLR	RECOMMENDED	APPROVED
1	2/8/96	AIR TERMINALS / PORTS	JWG RSS	
NO.	DATE	REVISION	BY	CHK.
			JWG	RSS
			TRACED	

SCALE AS SHOWN  
DATE 1/19/96  
JOB NO.  
DRAWING NO. D95-75-S1-1

DRAWING 1541-M-001  
STACK PORT ARRANGEMENT

Revision 1  
April 2012

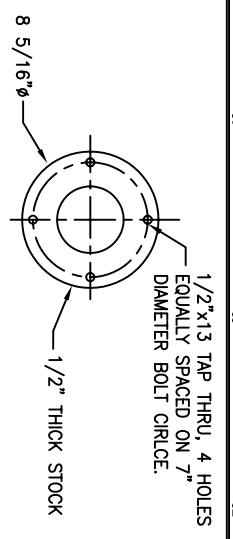
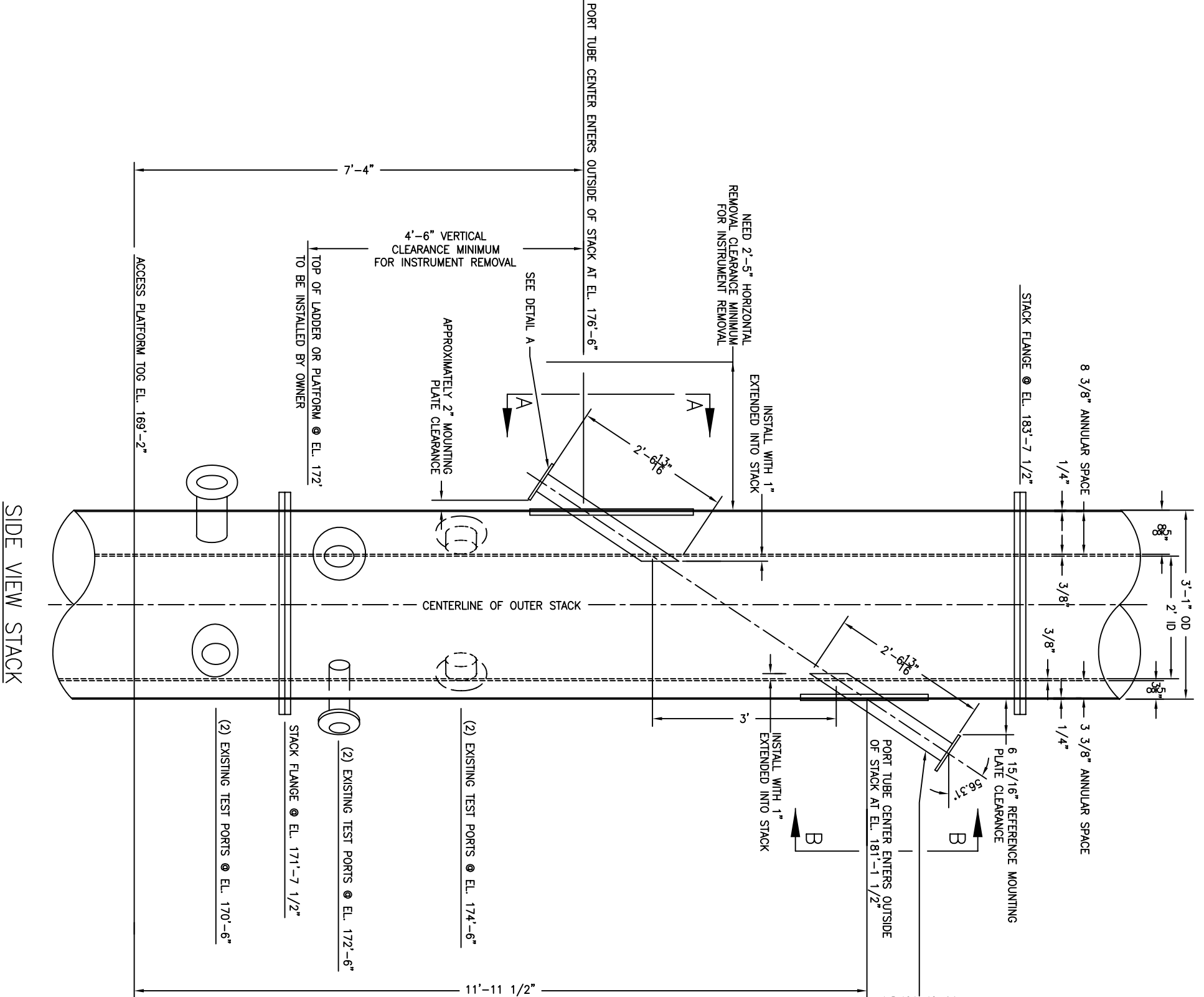

3.548" ID MINIMUM FIBERGLASS PIPE  
WALL THICKNESS MUST BE  
STRONG ENOUGH TO HOLD UP  
20 LB. SENSOR CONNECTED TO FLANGE.  
SEE DETAIL A FOR FLANGE DETAIL.  
CUT PIPE PARALLEL TO WALL INSIDE STACK  
TYPICAL FOR 2

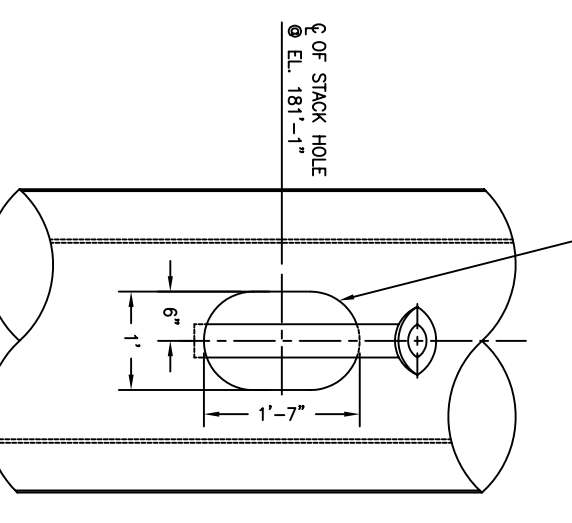
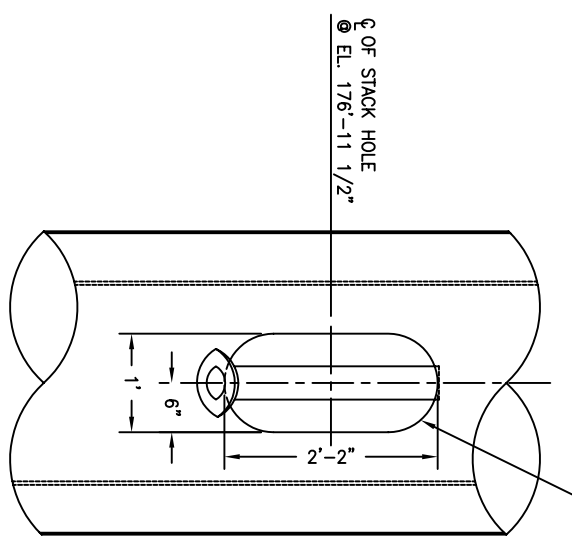
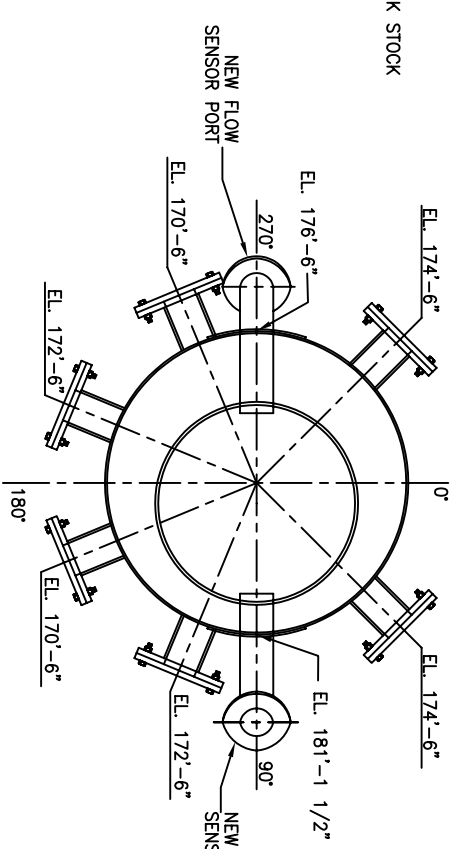

THIS PRINT AND ALL INFORMATION THERE ON IS THE PROPERTY OF THE CHAVOND-BARRY ENGINEERING CORPORATION AND IS SUBJECT TO RETURN UPON DEMAND. IT IS NOT TO BE MADE PUBLIC OR COPIED UNLESS AUTHORIZED BY THE ABOVE COMPANY. ALL RIGHTS TO PATENTABLE DESIGN OR INVENTION ARE RESERVED.

STACK SENSOR PORT ARRANGEMENT DETAIL				REVISIONS		DATE
NO	DWN	CK'D	APP			
<b>CBE CHAVOND-BARRY ENGINEERING CORP.</b> NJ Certificate of Authorization Number: 24GA27984700 400 Route 518 • P.O. Box 205 • Blawenburg, New Jersey 08504						
<b>US FILTER/WESTATES PARKER, ARIZONA</b>						
<b>STACK FLOW SENSOR PORT ARRANGEMENT</b>						
NO	DWN	CK'D	APP			

NORTH AMERICAN MODEL 6422 BURNER  
INFORMATION

Revision 1  
April 2012



**6422 Fire-All Dual-Fuel Burners** are widely used on heat treat and non-ferrous melting furnaces, kilns, ovens, air heaters, dryers, chemical process equipment, and other applications where superior temperature uniformity is required. (For higher temperature service, specify 6425 Burners.)

These sealed-in, nozzle-mix burners for gas and/or distillate oil are stable on stoichiometric ratio, with large amounts of excess air, or with up to 50% excess fuel (provided additional air for combustion is in the furnace near the burner).

**OPERATION**

Burners can be lighted at rich, lean, or correct air/fuel ratio, then immediately turned to high fire.

Required gas pressures are low: 1 psi at the burner for coke oven gas, less for natural gas. Required oil pressure at the burner is nearly zero, but a pressure drop of about 10 psi should be taken across the Sensitrol™ Valve.

The most common ratio control system for 6422 Burners uses a cross-connected regulator and Ratiotrol™. When appropriate for the application, flow balancing systems or fuel only control (see "Excess Air" paragraph) is very satisfactory.

If furnace temperatures after shutdown rise above 1900 F, pass some air through burner to prevent overheating. During gas operation, use at least 4 psi atomizing air to cool atomizer (full atomizing air may be used); or for extended periods of operation on gas, atomizer can be withdrawn and stored: Use a backplate and gasket to seal rear of burner (see Dimensions & Parts List 4422-2).

**LIGHTING/FLAME SUPERVISION**

A 4011 Pilot Set normally is used to light 6422 Burners. On gas, direct spark ignition of the burner is available--see Sheet 4055. A manual torch can be used in some applications.

Burners accept ultraviolet (UV) scanners for monitoring pilot or main flame. A flame rod can be used to monitor pilot or main **gas** fire. Adapters are listed in Bulletin 8832.

When using flame supervision, an **interrupted** pilot is required--do **not** use constant or intermittent pilots. If using direct spark ignition, turn off spark after burner lights.

**Table I. TOTAL AIR CAPACITIES\***  
scfh  
(for Btu/hr, multiply by 100)

Burner designation	16 psi air at burner
6422-2	2 600
6422-3	4 100
6422-4	6 300
6422-5	10 300
6422-6	15 700
6422-7-A	27 000
6422-7-B	33 500
6422-8-A	44 800

\* Includes combustion and atomizing air.

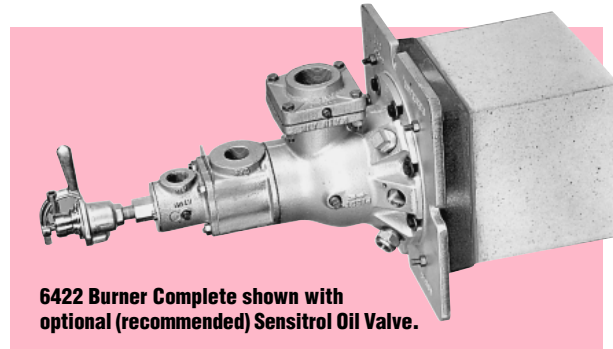

An observation port is furnished with all burners. Positions of pilot, flame detector, and observation port are interchangeable, as long as pilot and flame detector are mounted in adjacent holes.

**STANDARD CONSTRUCTION**

Burner bodies are heat resistant cast iron with Inconel air tubes. Mounting plate and tile assembly can be separated from the burner body for installation convenience. Air and gas connection orientation can be rotated in 90° intervals, but air and gas pipes should be brought in from the top or side to prevent oil dripping into them. When reassembling the burner, the pilot and flame detector notches in the tile and mounting must be in proper alignment with the pilot and flame detector connections on the burner body (applies to 6422-2 through 6422-6 sizes). Burner is complete with cast iron mounting plate and 9" long 3200 F castable burner tile which must be supported and sealed in a hard refractory furnace wall. (See page 2 of Dimensions 6422 for optional construction suitable for fiber lined furnaces.) When the furnace wall is thicker than the tile length, the tunnel beyond the end of the burner tile should be flared at a 30° or greater included angle, starting at the OD of the tile. Extension tiles are not recommended. (See Supplement DF-M1 for detailed tile installation recommendations.)

**TILE SUPPORT JACKETS**  
(6422- -LC, 6422- -L4, 6422- -L9)

6422 Burners with the standard 9" long square tiles are also available with support jackets for applications such as air heaters where frequently the tile is not supported by refractory. They also can be mounted in furnaces when desired. Jackets are available in three different metals and maximum temperature ratings. They must be protected with sufficient insulation so as not to exceed rated temperature. Maximum temperature rating for jacket metals depends upon frequency of heat-up/cool-down cycles. As an example, batch annealing furnaces that are heated and cooled every day should use the "intermittent exposure" ratings. Burners in a continuous annealing furnace that remain at the same temperature for months at a time, can use the higher "continuous" rating.

Designation	Jacket Metal	Continuous max.temp.	Intermittent exposure
6422- -LC	carbon steel	700 F	700 F
6422- -L4	304 SST	1600 F	1500 F
6422- -L9	309 SST	1900 F	1800 F

**EXCESS AIR**

Excess air can improve temperature uniformity by avoiding hot spots in front of burners, by churning furnace atmosphere to reduce stratification, and by creating positive furnace pressure to eliminate cold air infiltration.

Excess air can give very high effective burner turndown. Thus a furnace used for high temperature work (such as heat treating at 1900 F) with burners firing on stoichiometric air/fuel ratio can also be used for low temperature jobs (such as drawing or drying at 600 F) with burners firing on lean ratio.

**Table II. ATOMIZING AIR CAPACITIES in scfh**

Burner designation	air pressure drop across burner in osi					
	14	16	18	20	22	24
6422-2, -3, -4	500	520	560	600	620	650
6422-5	640	690	720	760	800	840
6422-6	800	850	910	950	1000	1050
6422-7-A,-7-B	870	930	990	1040	1100	1150
6422-8-A	2650	2840	3000	3170	3320	3480

**Table III. COMBUSTION AIR CAPACITIES in scfh**  
(not including atomizing air)

Burner designation	air pressure drop across burner in osi							approx. flame lengths with 16 osi Main Air (in open furnace)	
	0.1	1	5	6	8	12	16	gas	oil
6422-2	160	520	1 160	1 270	1 470	1 800	2 100	1/2'	1 1/2'
6422-3	280	890	1 980	2 160	2 500	3 050	3 550	1 1/2'	2'
6422-4	460	1 450	3 240	3 540	4 100	5 000	5 800	2'	2 1/2'
6422-5	750	2 370	5 300	5 800	6 700	8 150	9 450	2 1/2'	2 1/2'
6422-6	1180	3 700	8 300	9 100	10 500	12 900	14 800	3'	4'
6422-7-A	2070	6 550	14 600	16 000	18 500	22 700	26 200	6'	6'
6422-7-B	2580	8 150	18 200	19 900	23 000	28 200	32 600	6'	5'
6422-8-A	3320	10 500	23 500	25 800	29 700	36 400	42 000	7'	6'

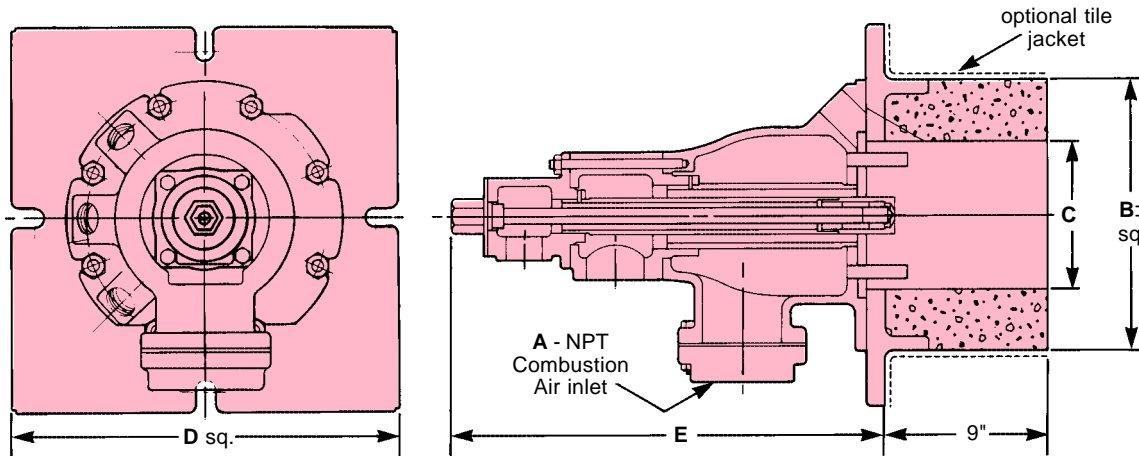

**NOTE:** For 6422-8-A, air and gas connections, cannot be piped in the same plane because the "flower pot" type air connection flange would interfere with the 2 1/2" gas line.

**CLEARANCE DIMENSIONS**  
(for details, see Dimensions 6422)

Burner designation	dimensions in inches				
	A	B ‡	C	D	E
6422-2	1 1/4	8 1/2	5	12	13 5/8
6422-3	1 1/2	8 1/2	5	12	13 5/8
6422-4	2	8 1/2	5	12	13 5/8
6422-5	2 1/2	8 1/2	5	12	13 5/8
6422-6	3	8 1/2	5	12	13 5/8
6422-7-A	4	10	7	13 1/2	17 7/8
6422-7-B	4	10	7	13 1/2	17 7/8
6422-8-A	6	10	7	13 1/2	17 7/8

‡ 6422- L\_ metal jackets add about 1" to tile OD.

**Table IV. MAXIMUM EXCESS AIR RATES in %**  
(without pilot)

Burner designation	GAS			OIL		
	Combustion Air pressure 1 osi	8 osi	14 osi	Combustion Air pressure 1 osi	8 osi	14 osi
6422-2	—	380	500	—	380	500
6422-3	330	1000	1300	210	480	670
6422-4	560	1560	1560	480	800	900
6422-5	1070	1440	1150	50	250	400
6422-6	380	1000	1400	140	560	610
6422-7-A	3200	4900	1000	160	330	450
6422-7-B	900	1450	1600	150	700	830
6422-8-A	460	660	400	200	280	350

DIMENSIONS SHOWN ARE SUBJECT TO CHANGE. PLEASE OBTAIN CERTIFIED PRINTS FROM NORTH AMERICAN MFG. CO. IF SPACE LIMITATIONS OR OTHER CONSIDERATIONS MAKE EXACT DIMENSION(S) CRITICAL.

**WARNING:** Situations dangerous to personnel and property can develop from incorrect operation of combustion equipment. North American urges compliance with National Safety Standards and Insurance Underwriters recommendations, and care in operation.

North American Mfg. Co., 4455 East 71st Street, Cleveland, OH 44105-5600 USA, Tel: +1.216.271.6000, Fax: +1.216.641.7852  
email: sales@namfg.com • www.namfg.com



**DIMENSIONS** in inches

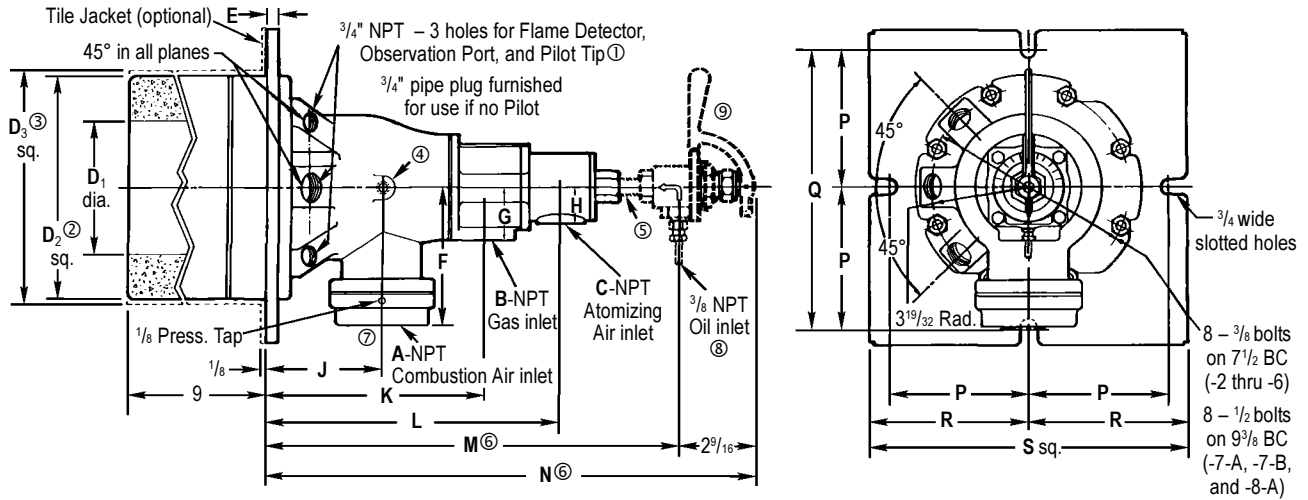

DIMENSIONS SHOWN ARE SUBJECT TO CHANGE. PLEASE OBTAIN CERTIFIED PRINTS FROM NORTH AMERICAN MFG. CO. IF SPACE LIMITATIONS OR OTHER CONSIDERATIONS MAKE EXACT DIMENSION(S) CRITICAL.

Burner designation	dimensions in inches																		
	A	B	C	D <sub>1</sub>	D <sub>2</sub> ②	D <sub>3</sub> ③	E	F	G	H	J	K	L	M ⑥	N ⑥	P	Q	R	S
6422-2	1 <sup>1</sup> / <sub>4</sub>	1	3/4	5	8 <sup>1</sup> / <sub>2</sub>	9 <sup>1</sup> / <sub>2</sub>	1/2	5 <sup>1</sup> / <sub>4</sub>	2	1 <sup>3</sup> / <sub>8</sub>	4 <sup>3</sup> / <sub>8</sub>	8 <sup>3</sup> / <sub>8</sub>	11 <sup>5</sup> / <sub>16</sub>	15 <sup>13</sup> / <sub>16</sub>	18 <sup>3</sup> / <sub>8</sub>	5 <sup>1</sup> / <sub>4</sub>	10 <sup>1</sup> / <sub>2</sub>	6	12
6422-3	1 <sup>1</sup> / <sub>2</sub>	1	3/4	5	8 <sup>1</sup> / <sub>2</sub>	9 <sup>1</sup> / <sub>2</sub>	1/2	5 <sup>1</sup> / <sub>4</sub>	2	1 <sup>3</sup> / <sub>8</sub>	4 <sup>3</sup> / <sub>8</sub>	8 <sup>3</sup> / <sub>8</sub>	11 <sup>5</sup> / <sub>16</sub>	15 <sup>13</sup> / <sub>16</sub>	18 <sup>3</sup> / <sub>8</sub>	5 <sup>1</sup> / <sub>4</sub>	10 <sup>1</sup> / <sub>2</sub>	6	12
6422-4	2	1 <sup>1</sup> / <sub>4</sub>	3/4	5	8 <sup>1</sup> / <sub>2</sub>	9 <sup>1</sup> / <sub>2</sub>	1/2	5 <sup>1</sup> / <sub>4</sub>	2	1 <sup>3</sup> / <sub>8</sub>	4 <sup>3</sup> / <sub>8</sub>	8 <sup>3</sup> / <sub>8</sub>	11 <sup>5</sup> / <sub>16</sub>	15 <sup>13</sup> / <sub>16</sub>	18 <sup>3</sup> / <sub>8</sub>	5 <sup>1</sup> / <sub>4</sub>	10 <sup>1</sup> / <sub>2</sub>	6	12
6422-5	2 <sup>1</sup> / <sub>2</sub>	1 <sup>1</sup> / <sub>2</sub>	1	5	8 <sup>1</sup> / <sub>2</sub>	9 <sup>1</sup> / <sub>2</sub>	1/2	5 <sup>1</sup> / <sub>4</sub>	2	1 <sup>3</sup> / <sub>8</sub>	4 <sup>3</sup> / <sub>8</sub>	8 <sup>3</sup> / <sub>8</sub>	11 <sup>5</sup> / <sub>16</sub>	15 <sup>13</sup> / <sub>16</sub>	18 <sup>3</sup> / <sub>8</sub>	5 <sup>1</sup> / <sub>4</sub>	10 <sup>1</sup> / <sub>2</sub>	6	12
6422-6	3	1 <sup>1</sup> / <sub>2</sub>	1	5	8 <sup>1</sup> / <sub>2</sub>	9 <sup>1</sup> / <sub>2</sub>	1/2	5 <sup>9</sup> / <sub>16</sub>	2	1 <sup>3</sup> / <sub>8</sub>	4 <sup>3</sup> / <sub>8</sub>	8 <sup>3</sup> / <sub>8</sub>	11 <sup>5</sup> / <sub>16</sub>	15 <sup>13</sup> / <sub>16</sub>	18 <sup>3</sup> / <sub>8</sub>	5 <sup>1</sup> / <sub>4</sub>	10 <sup>1</sup> / <sub>2</sub>	6	12
6422-7-A	4	2 <sup>1</sup> / <sub>2</sub>	1 <sup>1</sup> / <sub>4</sub>	7	10	11	9/16	6 <sup>15</sup> / <sub>16</sub>	2 <sup>5</sup> / <sub>8</sub>	2 <sup>1</sup> / <sub>8</sub>	5 <sup>7</sup> / <sub>8</sub>	11	15 <sup>1</sup> / <sub>8</sub>	20 <sup>1</sup> / <sub>16</sub>	22 <sup>5</sup> / <sub>8</sub>	6 <sup>1</sup> / <sub>8</sub>	12 <sup>1</sup> / <sub>4</sub>	6 <sup>3</sup> / <sub>4</sub>	13 <sup>1</sup> / <sub>2</sub>
6422-7-B	4	2 <sup>1</sup> / <sub>2</sub>	1 <sup>1</sup> / <sub>4</sub>	7	10	11	9/16	6 <sup>15</sup> / <sub>16</sub>	2 <sup>5</sup> / <sub>8</sub>	2 <sup>1</sup> / <sub>8</sub>	5 <sup>7</sup> / <sub>8</sub>	11	15 <sup>1</sup> / <sub>8</sub>	20 <sup>1</sup> / <sub>16</sub>	22 <sup>5</sup> / <sub>8</sub>	6 <sup>1</sup> / <sub>8</sub>	12 <sup>1</sup> / <sub>4</sub>	6 <sup>3</sup> / <sub>4</sub>	13 <sup>1</sup> / <sub>2</sub>
6422-8-A	6	2 <sup>1</sup> / <sub>2</sub>	2	7	10	11	9/16	10 <sup>11</sup> / <sub>16</sub>	2 <sup>5</sup> / <sub>8</sub>	1 <sup>3</sup> / <sub>4</sub>	5 <sup>7</sup> / <sub>8</sub>	11	15 <sup>1</sup> / <sub>8</sub>	20 <sup>1</sup> / <sub>16</sub>	22 <sup>5</sup> / <sub>8</sub>	6 <sup>1</sup> / <sub>8</sub>	12 <sup>1</sup> / <sub>4</sub>	6 <sup>3</sup> / <sub>4</sub>	13 <sup>1</sup> / <sub>2</sub>

Burner designation	wt, lb	Recommended	
		Sensitrol™ Oil Valve ⑨	Pilot Size
6422-2	83	1813-02-A	
6422-3	83	1813-02-A	4011-11
6422-4	83	1813-02-A	(or)
6422-5	83	1813-02-A	4011-12
6422-6	83	1813-02-B	
6422-7-A	139	1813-02-C	4011-11
6422-7-B	139	1813-02-C	(or)
6422-8-A	145	1813-02-D	4011-12

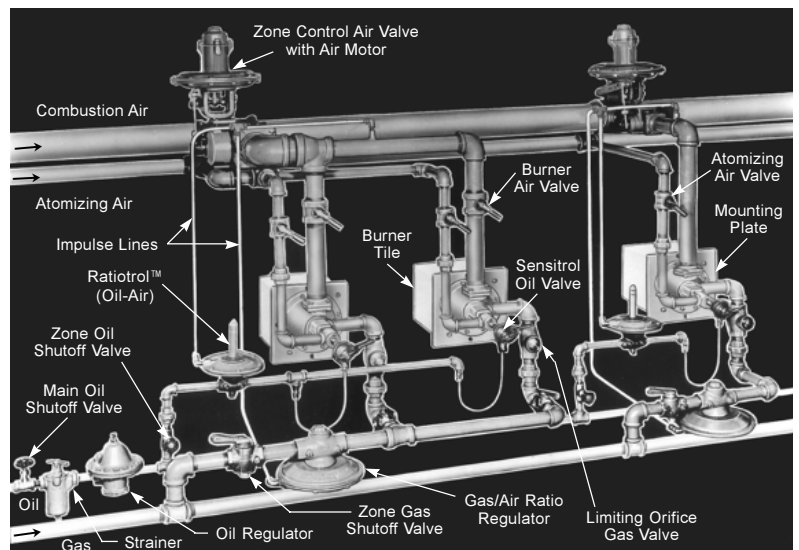

**Piping arrangement for single- and double-burner zones.**

- ① Pilot, Flame Detector, and Observation Port positions are interchangeable, as long as pilot and flame detector are in adjacent holes.
- ② Opening in furnace shell should be about 1/2" larger than dimension D<sub>2</sub> to allow for fillets and draft on mounting plate.
- ③ For 6422- -LC, -L4 and -L9 Burners only. Opening in oven shell should be about 1/4" larger than dimension D<sub>3</sub>.
- ④ 1/4" body air pressure tap on -2, -3, -4, -5, and -6. 1/8" body air pressure tap on -7-A, -7-B and -8-A.
- ⑤ Pipe nipple not furnished by North American.
- ⑥ Dimensions M and N assume the use of a 3/8" NPT close nipple between burner and Sensitrol Oil Valve.
- ⑦ For 6422-8-A, air and gas connections cannot be piped in the same plane because the "flower pot" type air connection flange would interfere with the 2<sup>1</sup>/<sub>2</sub>" gas line.
- ⑧ Metal tubing is offered as an extra cost option (order as P.N. 3-0310-7).
- ⑨ Optional (recommended) Sensitrol Oil Valve is not included as part of the burner assembly, and must be ordered separately.

## ALTERNATIVE MODELS

6422 Burners for Fiber Lined Furnaces. For furnaces with ceramic fiber walls, special mounting/tile construction is available: 11<sup>3</sup>/<sub>8</sub>" diameter tile, jacketed in RA330 expanded metal for all but 2" of its length; a circular mounting flange factory-installed from 2" to 9" ("Z" dimension) from the hot face of the tile.

Customer must specify this dimension to nearest 1/2" so tile face is about flush with inside furnace wall.

This construction is suitable for 2000 F furnace temperature.

See Supplement DF-M2 for detailed tile installation recommendations for fiber-lined furnaces.

Dimensions in inches			
Size designation	A	B	Z
-2 thru -6	5	13 <sup>3</sup> / <sub>8</sub>	†
-7-A thru -8-A	7	14 <sup>7</sup> / <sub>8</sub>	†

† "Z" dimension variable in 1/2" increments from 2" to 9".

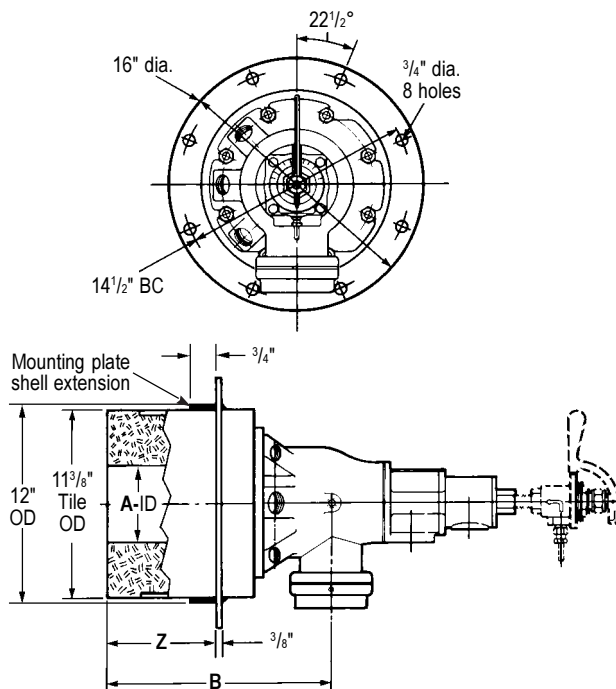

To order, specify: 6422-(code)-(A or B if applicable) (Z) Burner complete. (Order 1813 Sensitrol™ Oil Valve separately--it is not included in complete burner assembly.) Include Z dimension in the burner description: between 2" and 9", written to the nearest 0.5" as a decimal.

*Example:* Line Item 10 = 6422-7-AZ Burner complete with Z dimension of 6.0"  
Line Item 20 = 1813-02-C Sensitrol Oil Valve.

**6422 Burners with Extra Pilot and Flame Detector Location.** The fixed relationship between 6422 Burner air connections and pilot/flame detector holes occasionally presents problems in mounting pilots and flame detectors clear of furnace buckstays or other structural members.

6422-2 through -6 Burners can be furnished with a 4-hole OC3-2042 burner body that has a set of pilot and flame detector holes on each side. Either set can be used and one on the other side used for an observation port--plug any unused holes.

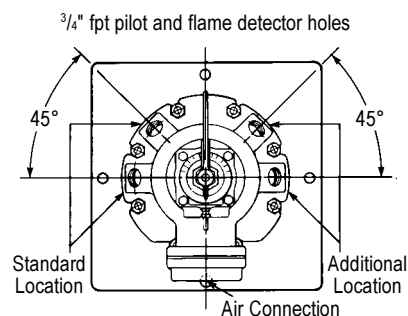

**To order, specify:** 6422D-(code) Burner complete. (Order 1813 Sensitrol Oil Valve separately--it is not included in complete burner assembly.)

*Example:* Line Item 10 = 6422D-2 Burner complete with Special Double-Boss Body  
Line Item 20 = 1813-02-A Sensitrol Oil Valve

**WARNING:** Situations dangerous to personnel and property can develop from incorrect operation of combustion equipment. North American urges compliance with National Safety Standards and Insurance Underwriters recommendations, and care in operation.

North American Mfg. Co., 4455 East 71st Street, Cleveland, OH 44105-5600 USA, Tel: +1.216.271.6000, Fax: +1.216.641.7852  
email: sales@namfg.com • www.namfg.com



NORTH AMERICAN MODEL 6514 BURNER  
INFORMATION

Revision 1  
April 2012



6514 FIRE•ALL Dual-Fuel Burners are nozzle mix, sealed-in burners for gas, light oil, or heavy oil. Capable of efficient operation throughout a wide temperature range, these burners are equally at home on low temperature ovens and high temperature forge and melting furnaces.

Ruggedly built for sustained, maintenance-free operation, 6514 Burners also provide for quick change of fuels without disturbing process operations.

Sealed mountings help maintain furnace pressure, controlled atmosphere, and closer air/fuel ratio control--all contributing to better product quality.

Fire•All Burners have been used for years on all types of furnaces with great success.

**COMBUSTION CHARACTERISTICS**

**Oil.** Oil viscosity at the burners must not exceed 100 SSU. Minimum atomizing air pressure at the burners is 14 osi for light oil, 22 osi for heavy oil.

**Gas.** Atomizing air (4 osi minimum) should be left on to protect the atomizer. Maximum required natural gas pressure at the burner for stoichiometric ratio is about 1/4 of the combustion air pressure.

**Air/Fuel Ratio.** 6514 Dual-Fuel Burners are stable with at least 100% excess air. They also can operate with excess fuel without forming carbon, but additional air for complete combustion must be available in the furnace near the burner.

For limits in a specific case, either rich or lean, consult North American.

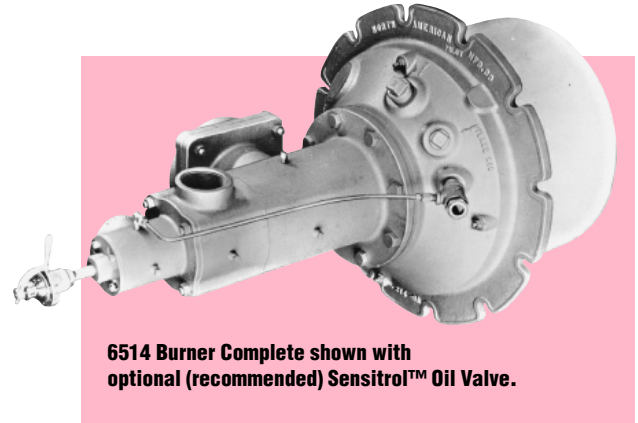

**6514 Burner Complete shown with optional (recommended) Sensitrol™ Oil Valve.**

**Turndown.** Fire•All Burners can be turned down to atomizing air only (with fuel to match) except when burning residual oils in a cold, tight furnace. For prolonged operation on atomizing air only, specify an alloy burner nose if furnace temperature is above 1600 F.

**Preheated Air.** 6514 Burners are designed for use with ambient air. They are suitable for some preheated air applications (up to 700 F preheat). Consult North American.

**Total air capacities  
(including main and atomizing air)**

Burner designation	16 osi air pressure drop across the burner				24 osi air pressure drop across the burner				Approx. flame lengths with 16 osi main air (in open furnace)
	Air <sup>①</sup> scfh	Light oil <sup>②</sup> gph	Heavy oil <sup>③</sup> gph	Gas <sup>④</sup> scfh	Air scfh	Light oil gph	Heavy oil gph	Gas scfh	
<b>6514-6</b>	17 900	13	12	1 790	21 900	16	15	2 190	4' - 5'
<b>6514-7</b>	28 400	21	19	2 840	34 800	26	23	3 480	5' - 6'
<b>6514-8-A</b>	48 900	36	33	4 890	60 000	44	40	6 000	8' - 9'
<b>6514-8-B</b>	81 500	60	54	8 150	100 000	74	67	10 000	9' - 12'
<b>6514-9</b>	165 000	122	110	16 500	202 000	150	135	20 200	15' - 18'
<b>6514-10</b>	247 000	183	165	24 700	303 000	224	202	30 300	20'

① For Btu/hr, multiply by 100

② Light oil at 135 000 Btu/gal.

③ Heavy oil at 150 000 Btu/gal.

④ Natural gas at 1000 Btu/cf.

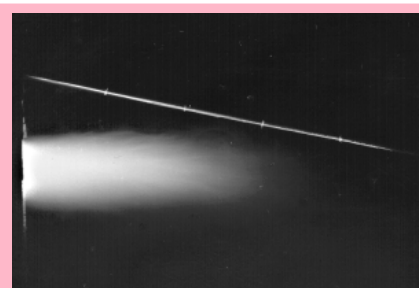

**Gas (left) and light oil flames for 6514-6 Dual-Fuel Burner with 16 osi main and atomizing air pressure drop across burner. White lines on pipe above flame indicate 1' intervals.**

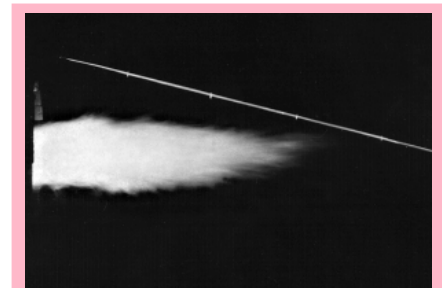

**SPECIFICATIONS**

**Flame Supervision.** An ultraviolet cell will monitor pilot or main flame on gas or oil. For maximum safety, North American urges interrupted pilots when flame safeguards are used--pilots should be on only for a preset ignition period (usually 15 seconds), after which flame supervision detects main fire only. Adapters for mounting flame detection devices on 6514 Burners are tabulated on Bulletin 8832.

**Tile/Installation.** Burner tiles are cast refractory rated for 2800F furnace temperature. They should be supported securely in the furnace wall by castable refractory (not insulation) at least 9" thick all around the tile, extending back to the furnace shell and securely anchored to it. (See Supplement DF-M1.)

Tiles are replaceable in the field except for the 6514-10, whose mounting must be returned to the factory for tile replacement (or purchase a spare mounting plate with a tile cast onto it).

For furnace walls thicker than the length of the tile, the tunnel beyond the end of the tile should be flared at a 30° (included) angle, starting at the OD of the tile. If this is not practical, consult North American for specific recommendations.

**Complete burners include** tile, mounting plate, and an observation port into which a small quantity of atomizing air is introduced to keep the glass clear. Order pilot tips and Sensitrol™ Oil Valve separately.

**SPECIAL OPTIONS**

The following options are available for the 6514 burner but require consultation with your North American field engineer for application and ordering information.

1. **Increased capacities** - most sizes are available with up to 30% extra capacity.
2. **Hinged bodies** for easy access to internals.
3. **Short flame** versions are available in most sizes.
4. **Special high pressure oil atomizers** are available.

‡ Cleaning air must be introduced into the port downstream of the sensor to keep oil and poc's off the lens.

**Jacketed Tiles.** 6514 Burners are available with support jackets around the tile for applications where the tile is not supported by furnace refractory.

Jackets are available in three different metals and have maximum temperature ratings for each. They must be protected with sufficient insulation so as not to exceed rated temperature.

Maximum temperature rating for jacket metals depends upon frequency of heat-up/cool-down cycles. As an example, batch annealing furnaces that are heated and cooled every day should use the "intermittent exposure" ratings. Continuous annealing furnaces that remain at the same temperature for months at a time, can use the higher "continuous" rating.

Designation	Jacket Metal	Continuous max.temp.	Intermittent exposure
6514- -LC	carbon steel	700 F	700 F
6514- -L4	304 stainless	1600 F	1500 F
6514- -L9	309 stainless	1900 F	1800 F

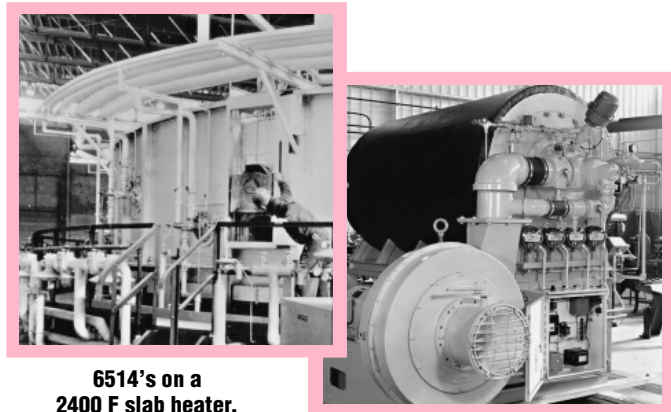

6514's on a 2400 F slab heater.

6514 on a 600 F air heater.

Burner designation	Main air capacities in scfh						Atomizing air capacities in scfh					
	Air pressure drop across the burner in psi						Air pressure drop across the burner in psi					
	1	5	6	8	12	16	14	16	18	20	22	24
6514-6	3 710	8 300	9 100	10 500	12 900	14 900	2 800	3 000	3 180	3 360	3 510	3 660
6514-7	6 100	13 600	15 000	17 200	21 000	24 400	3 770	4 030	4 270	4 500	4 720	4 900
6514-8-A	10 600	23 700	26 000	30 000	36 700	42 400	6 050	6 500	7 000	7 300	7 600	7 850
6514-8-B	17 600	39 200	43 000	49 600	60 500	70 000	10 600	11 300	12 000	12 700	13 200	13 800
6514-9	36 600	82 000	89 500	104 000	127 000	146 000	17 200	18 400	19 600	20 700	21 600	22 500
6514-10	54 500	122 000	135 000	154 000	189 000	218 000	27 200	29 100	30 900	32 600	34 100	35 500

**CLEARANCE DIMENSIONS** (for details, see Dimensions 6514)

Burner designation	dimensions in inches					
	A	B	C	D	E	F
6514 & 6514-6-L	3	15	10 <sup>3</sup> / <sub>8</sub>	19 <sup>1</sup> / <sub>2</sub>	23 <sup>5</sup> / <sub>16</sub>	9
6514 & 6514-7-L	4	16	11 <sup>3</sup> / <sub>8</sub>	20 <sup>1</sup> / <sub>2</sub>	25 <sup>1</sup> / <sub>2</sub>	9
6514 & 6514-8-AL	6	17 <sup>3</sup> / <sub>4</sub>	12 <sup>3</sup> / <sub>8</sub>	22 <sup>3</sup> / <sub>4</sub>	32 <sup>1</sup> / <sub>16</sub>	10
6514 & 6514-8-BL	6	19	13 <sup>1</sup> / <sub>2</sub>	24	35 <sup>15</sup> / <sub>16</sub>	13
6514 & 6514-9-L	8	23	16	28	44 <sup>3</sup> / <sub>16</sub>	13 <sup>1</sup> / <sub>2</sub>
6514 & 6514-10-L	10	27 <sup>1</sup> / <sub>2</sub>	20 <sup>1</sup> / <sub>2</sub>	32 <sup>1</sup> / <sub>2</sub>	50 <sup>9</sup> / <sub>16</sub>	13 <sup>7</sup> / <sub>16</sub>

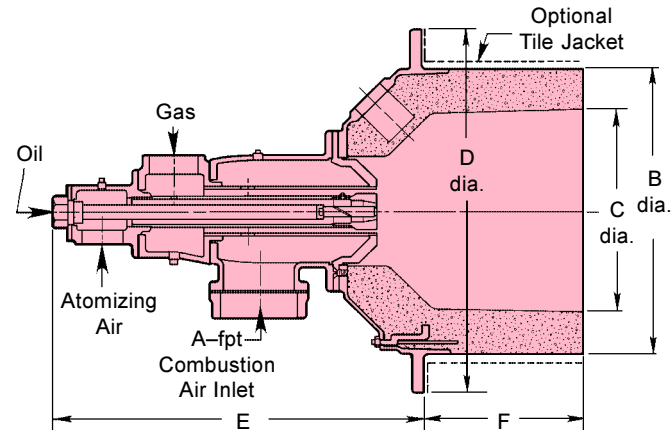

DIMENSIONS SHOWN ARE SUBJECT TO CHANGE. PLEASE OBTAIN CERTIFIED PRINTS FROM NORTH AMERICAN MFG. CO. IF SPACE LIMITATIONS OR OTHER CONSIDERATIONS MAKE EXACT DIMENSION(S) CRITICAL.

**WARNING:** Situations dangerous to personnel and property can develop from incorrect operation of combustion equipment. North American urges compliance with National Safety Standards and Insurance Underwriters recommendations, and care in operation.

North American Mfg. Co., 4455 East 71st Street, Cleveland, OH 44105-5600 USA, Tel: +1.216.271.6000, Fax: +1.216.641.7852  
email: sales@namfg.com • www.namfg.com



**DIMENSIONS** – Main air, gas, atomizing air, and oil connections can be rotated relative to one another and to the mounting plate. Drawings show connections as assembled at the factory. These arrangements reduce maintenance by preventing oil dripping into air or gas manifolds (which should be above burners) and by minimizing dirt accumulation in pilots and flame supervisory devices. Pilot and main air connections cannot be aligned in the same direction.

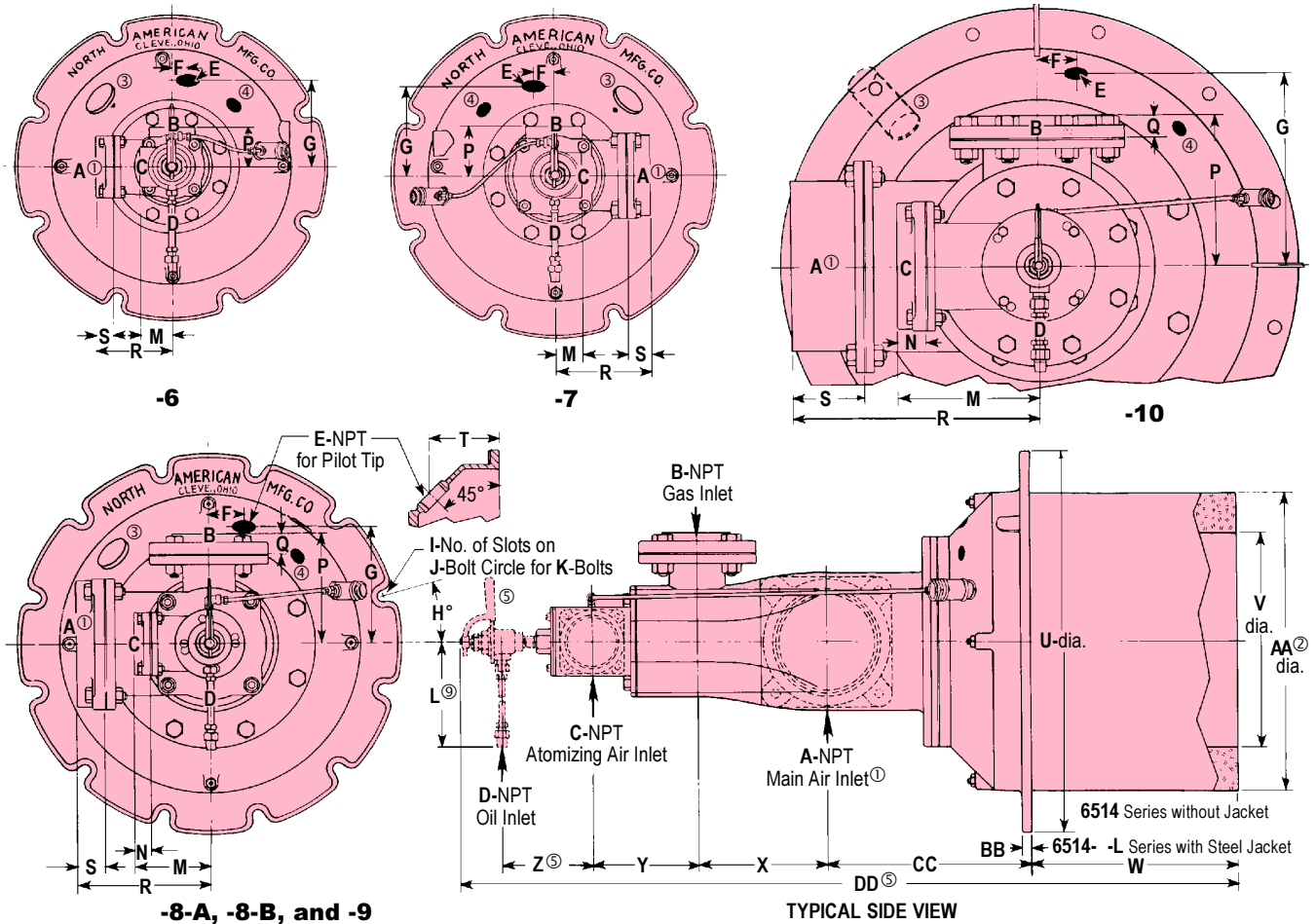

DIMENSIONS SHOWN ARE SUBJECT TO CHANGE. PLEASE OBTAIN CERTIFIED PRINTS FROM NORTH AMERICAN MFG. CO. IF SPACE LIMITATIONS OR OTHER CONSIDERATIONS MAKE EXACT DIMENSION(S) CRITICAL.

Burner designation	Common dimensions in inches and degrees for 6514 and 6514- -L														
	A <sup>①</sup>	B	C	D	E	F	G	H <sup>°</sup>	I	J	K	L <sup>⑨</sup>	M	N	P
6514-6	3	2	1½	¾	¾	1	5 <sup>17</sup> / <sub>32</sub>	22½	8	18	⅝	19¾	2	—	2½
6514-7	4	2½	2	¾	1¼	1¼	5¾	22½	8	19	⅝	19¾	1¾	—	3¼
6514-8-A	6	2½	2½	¾	1¼	1½	6 <sup>7</sup> / <sub>8</sub>	15	12	21¼	⅝	19¾	2 <sup>3</sup> / <sub>8</sub>	—	3 <sup>7</sup> / <sub>8</sub>
6514-8-B	6	3 <sup>⑧</sup>	3 <sup>⑦</sup>	¾	1¼	2¼	7 <sup>3</sup> / <sub>8</sub>	15	12	22½	⅝	19¾	5 <sup>3</sup> / <sub>16</sub> <sup>①</sup>	1½	6 <sup>13</sup> / <sub>16</sub>
6514-9	8	4 <sup>⑧</sup>	4 <sup>⑦</sup>	½	1½	2¼	9 <sup>7</sup> / <sub>8</sub>	15	12	26½	⅝	20¾	7 <sup>13</sup> / <sub>16</sub> <sup>①</sup>	1½	8¾
6514-10	10	6 <sup>⑧</sup>	6 <sup>⑦</sup>	½	1½	2½	12 <sup>3</sup> / <sub>16</sub>	15	12	30½	¾	20¾	8 <sup>13</sup> / <sub>16</sub> <sup>①</sup>	1¾	9 <sup>5</sup> / <sub>8</sub>

Burner designation	Common dimensions in inches for 6514 and 6514- -L											for 6514 only				wt lb
	Q	R	R <sub>1</sub> <sup>⑥</sup>	S	T	U	V	W	X	Y	Z <sup>⑤</sup>	AA <sup>②</sup>	BB	CC	DD <sup>⑤</sup>	
6514-6	—	5 <sup>3</sup> / <sub>16</sub>	10 <sup>3</sup> / <sub>8</sub>	1½	3 <sup>5</sup> / <sub>16</sub>	19½	10 <sup>3</sup> / <sub>8</sub>	9	3 <sup>7</sup> / <sub>8</sub>	4	4 <sup>1</sup> / <sub>16</sub>	15	5 <sup>8</sup> / <sub>8</sub>	8 <sup>5</sup> / <sub>16</sub>	31 <sup>11</sup> / <sub>16</sub>	165
6514-7	—	6 <sup>1</sup> / <sub>16</sub>	10 <sup>1</sup> / <sub>8</sub>	1½	3 <sup>15</sup> / <sub>16</sub>	20½	11 <sup>3</sup> / <sub>8</sub>	9	4 <sup>11</sup> / <sub>16</sub>	4 <sup>1</sup> / <sub>16</sub>	4 <sup>7</sup> / <sub>16</sub>	16	5 <sup>8</sup> / <sub>8</sub>	9 <sup>1</sup> / <sub>4</sub>	34	215
6514-8-A	—	7 <sup>5</sup> / <sub>16</sub>	11¼	1¾	4 <sup>5</sup> / <sub>16</sub>	22¾	12 <sup>3</sup> / <sub>8</sub>	10	6 <sup>1</sup> / <sub>4</sub>	4 <sup>15</sup> / <sub>16</sub>	4 <sup>15</sup> / <sub>16</sub>	17¾	5 <sup>8</sup> / <sub>8</sub>	12 <sup>7</sup> / <sub>8</sub>	41 <sup>9</sup> / <sub>16</sub>	300
6514-8-B	1 <sup>3</sup> / <sub>16</sub>	8 <sup>7</sup> / <sub>16</sub>	12 <sup>3</sup> / <sub>8</sub>	1¾	4 <sup>5</sup> / <sub>16</sub>	24	13½	13	8 <sup>1</sup> / <sub>8</sub>	6 <sup>1</sup> / <sub>16</sub>	5 <sup>3</sup> / <sub>16</sub>	19	5 <sup>8</sup> / <sub>8</sub>	12 <sup>7</sup> / <sub>8</sub>	48 <sup>7</sup> / <sub>16</sub>	410
6514-9	1 <sup>5</sup> / <sub>16</sub>	13 <sup>3</sup> / <sub>8</sub>	—	3 <sup>13</sup> / <sub>16</sub>	6 <sup>3</sup> / <sub>16</sub>	28	16	13½	11 <sup>5</sup> / <sub>16</sub>	8 <sup>7</sup> / <sub>16</sub>	6 <sup>3</sup> / <sub>16</sub>	23	5 <sup>8</sup> / <sub>8</sub>	14 <sup>11</sup> / <sub>16</sub>	57 <sup>3</sup> / <sub>16</sub>	705
6514-10	1 <sup>9</sup> / <sub>16</sub>	15 <sup>7</sup> / <sub>16</sub>	—	4 <sup>3</sup> / <sub>8</sub>	5 <sup>15</sup> / <sub>16</sub>	32½	20½	13 <sup>7</sup> / <sub>16</sub> †	13 <sup>1</sup> / <sub>16</sub>	11 <sup>3</sup> / <sub>16</sub>	6 <sup>11</sup> / <sub>16</sub>	27½	½	16 <sup>1</sup> / <sub>8</sub>	63 <sup>5</sup> / <sub>8</sub>	990

See back for notes and additional information, including 6514- -L dimensions and weights.  
† 6514-10 only is offered with a short (2") tile designated 6514-10-S.

Burner designation	for 6514- -L only				wt lb	for 6514 and 6514- -L only	
	AA	BB	CC	DD		Recommended Sensitrol™ oil valve	Recommended pilot tip
<b>6514-6</b>	16	<sup>3</sup> / <sub>4</sub>	<sup>8</sup> / <sub>16</sub>	<sup>32</sup> / <sub>16</sub>	190	1813-02-C	4021-12
<b>6514-7</b>	17	<sup>3</sup> / <sub>4</sub>	<sup>9</sup> / <sub>8</sub>	<sup>34</sup> / <sub>2</sub>	245	1813-02-D	4025-0-T
<b>6514-8-A</b>	<sup>18</sup> / <sub>4</sub>	<sup>3</sup> / <sub>4</sub>	13	<sup>42</sup> / <sub>16</sub>	335	1813-02-D	4025-0-T
<b>6514-8-B</b>	20	<sup>3</sup> / <sub>4</sub>	13	<sup>48</sup> / <sub>16</sub>	455	1813-02-D	4025-0-T
<b>6514-9</b>	<sup>24</sup> / <sub>4</sub>	<sup>13</sup> / <sub>16</sub>	<sup>14</sup> / <sub>8</sub>	<sup>57</sup> / <sub>16</sub>	755	1813-01	4025-2-T
<b>6514-10</b>	<sup>27</sup> / <sub>2</sub>	<sup>11</sup> / <sub>16</sub>	<sup>16</sup> / <sub>16</sub>	64	1020	1813-01	4025-2-T

- ① Flanged connection--a standard North American square threaded flange is used for sizes -6, -7, -8 main air connections, but SW style inlet may be specified with no change in price. An SW inlet (suitable for slip-on or welded connection) is standard for -9 and -10 burners.
- ② Opening in furnace shell or outer wall must be <sup>1</sup>/<sub>2</sub>" larger than dimension "AA" to allow for mounting plate fillet and draft.
- ③ Blank boss--as a no cost special may be specified with a 2" pipe tap for photocell, or a <sup>1</sup>/<sub>2</sub>" tap suitable for 5025-3-1T Oil Pilot, in which case North American will drill out <sup>1</sup>/<sub>2</sub>" web of refractory left in tile before shipment, and the burner nose will be positioned so none of its holes are in front of that opening. Available upon request. For -10 size, which has no boss, one half of an appropriately sized coupling is added when specified.
- ④ 1" fpt for electrode or UV flame detector.
- ⑤ Pipe nipple and optional (recommended) Sensitrol Oil Valve are not included as part of the burner assembly, and must be ordered separately. Dimensions Z and DD assume a <sup>3</sup>/<sub>8</sub>" close nipple between burner and Sensitrol Oil Valve (6514-6 through -8-B) and a <sup>1</sup>/<sub>2</sub>" close nipple between burner and Sensitrol Valve (6514-9 and -10).
- ⑥ Applies when optional SW inlet is specified.
- ⑦ Flanged connection--a standard North American square threaded flange is used.
- ⑧ Flanged connection--a standard ANSI 125 psi threaded flange is used.
- ⑨ If Optional tubing purchased from North American.

ANSI or SW flanges: Flat face companion flanges and full face gaskets are supplied with this equipment. Do not use raised face flanges that may damage mating flange.

## Ordering Information

To order, specify: 6514-(code)-(A or B if applicable) Burner complete and list 1813 Sensitrol Oil Valve separately.

*Example:* 6514-8-B Burner complete  
1813-02-D Sensitrol Oil Valve

### Options:

Add modifier to third term: BO = Burner only (less mounting and tile)  
LC = carbon steel tile jacket  
L4 = 304 SST tile jacket  
L9 = 309 SST tile jacket

6514-8-AL4 Burner complete (with 304 SST tile jacket)  
1813-02-D Sensitrol Oil Valve

6514-8-BBO Burner only

### Optional short tile for 6514-10

*Example:* 6514-10-S Burner complete with short tile

**WARNING:** Situations dangerous to personnel and property can develop from incorrect operation of combustion equipment. North American urges compliance with National Safety Standards and Insurance Underwriters recommendations, and care in operation.

North American Mfg. Co., 4455 East 71st Street, Cleveland, OH 44105-5600 USA, Phone 216-271-6000, Facsimile 216-641-7852  
E-mail sales@namfg.com • www.namfg.com

DRAWING ASC303-03  
CEMS FLOW DIAGRAM

Revision 1  
April 2012

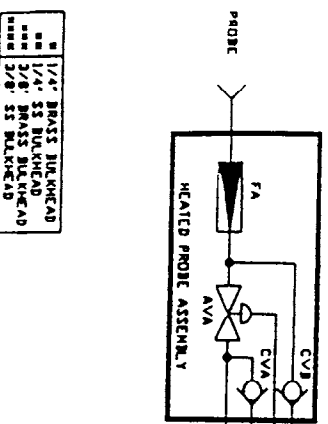

- 1/4" BRASS BURHEAD
- 1/8" BRASS BURHEAD
- 3/8" BRASS BURHEAD
- 3/8" SS BURHEAD

**INSTRUMENT AIR REQUIREMENTS:**  
 99% CLEAN OIL-FREE AIR  
 Dewpoint: -30 DEG. F  
 Pressure: 8 BAR  
 Flowrate: 25000 l/min  
 Purge Frequency: 400 l/min for 15 SECS.  
 1 TIME PER HOUR.

**CALIBRATION GAS REQUIREMENTS:**

ZERO GAS	BALANCE N2
SPAN GAS 1	CO - 80 ppm O2 - 8% BALANCE N2
SPAN GAS 2	CO - 800 ppm BALANCE N2

**RANGES:**

CO HIGH	0 - 100 ppm
CO LOW	0 - 100 ppm
REV.	0 - 25%

**PARTS BLOCK**

REV.	DESCRIPTION	QTY
1	1/4" BRASS BURHEAD	1
1	1/8" BRASS BURHEAD	1
1	3/8" BRASS BURHEAD	1
1	3/8" SS BURHEAD	1
1	1/4" BRASS BURHEAD	1
1	1/8" BRASS BURHEAD	1
1	3/8" BRASS BURHEAD	1
1	3/8" SS BURHEAD	1
1	1/4" BRASS BURHEAD	1
1	1/8" BRASS BURHEAD	1
1	3/8" BRASS BURHEAD	1
1	3/8" SS BURHEAD	1

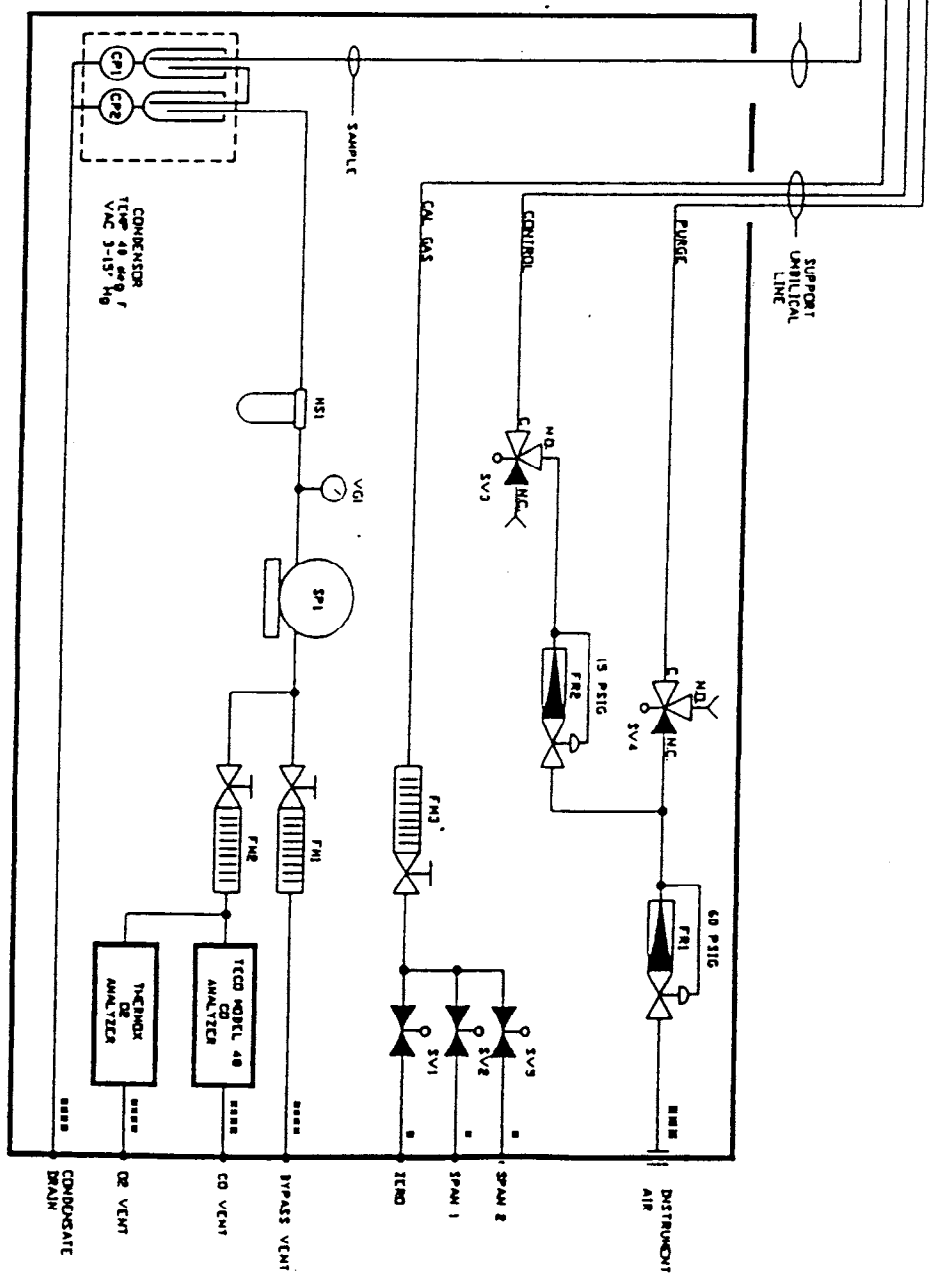

WESTAR LABS  
 2520 NUTMEG ST  
 PHOENIX, ARIZONA 85016  
 P.O. NO. 59024  
 ALTECH SYSTEMS NO. A10000

THIS DRAWING AND THE INFORMATION CONTAINED HEREIN ARE PROPRIETARY AND MAY NOT BE USED FOR THE DESIGN, PRODUCTION, INSTALLATION OR OPERATION OF ANY EQUIPMENT OR PROCESS EXCEPT AS SPECIFIED IN THE CONTRACT WITH IT.

NO.	REV. NO.	DATE	APPR.	DATE	NO.	REVISION

**ALTECH SYSTEMS CORP**  
 1100 S. CHANDLER COURT, BIRMINGHAM, AL 35204

**SAMPLE FLOW DIAGRAM**

PROJECT	VESTAR/ARIZONA	SCALE	NONE
DRAWN	BAVHTE	DATE	9/6/93
CWB		DATE	
APPR.		DATE	

ASC303-03

AMETEK O<sub>2</sub> ANALYZER SPECIFICATIONS

Revision 1  
April 2012



# ***Stack Gas User's Manual***

---

*Rev. B*

*August, 1993*



Process and Analytical Instruments Division  
150 Freeport Road  
Pittsburgh, PA 15238  
Phone (412) 828-9040  
Fax (412) 826-0399

# FLOW DIAGRAM

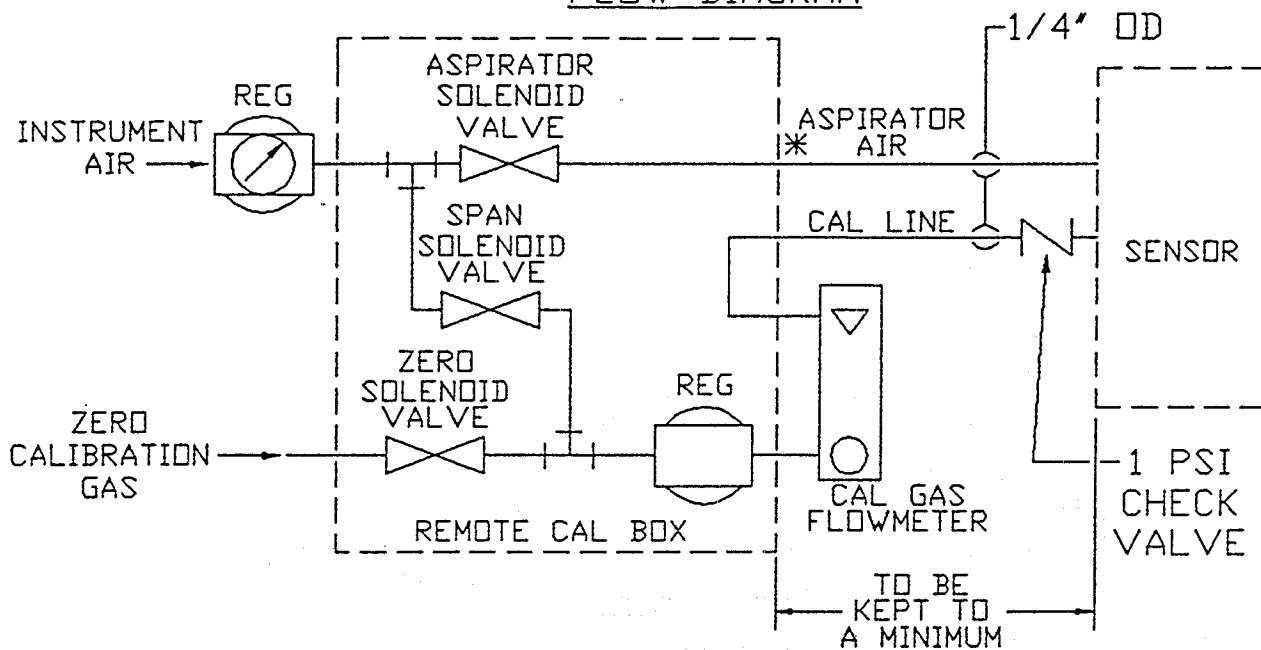

\* WDG IV - TO ASPIRATOR AIR REGULATOR ON SENSOR  
 WDG HP - NOT NEEDED, THIS OUTLET IS PLUGGED  
 STACK GAS - ASPIRATOR IS OPTIONAL

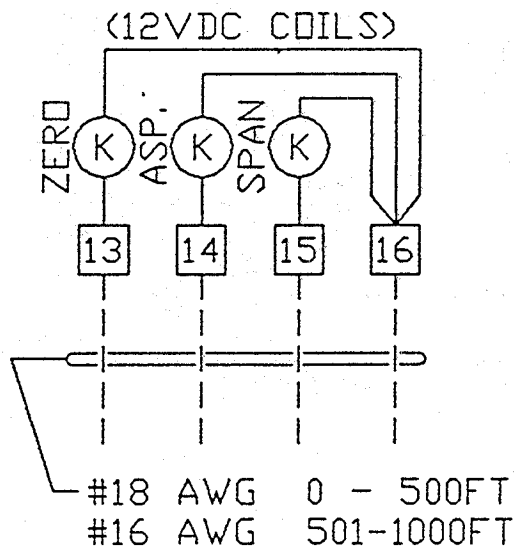

## WIRING

FIGURE 2

## VII. SPECIFICATIONS

### OXYGEN ANALYZER

PRINCIPLE OF OPERATION	Zirconium oxide electrochemical cell.
ACCURACY	± 2 percent of measured value
REPEATABILITY	±0.2 percent of measured value.
DRIFT	Less than 0.1% of cell output per month.
RESPONSE	90 percent of step change in less than five seconds.
ASPIRATOR AIR REQUIREMENTS (When supplied)	10 to 20 scfh (4.72 to 9.4 L/min.) to 100 PSI (.05 to 7.04 kg/cm <sup>2</sup> ) aspirator air regulator.
MAX. SAMPLE TEMPERATURE	400°F (200°C).
SAMPLE PRESSURE	2 to 20 inches WC.
AMBIENT TEMPERATURE	5 to 160°F (-20 To 71°C).
POWER REQUIREMENTS	115 VAC, 50/60 Hz (230 VAC optional) 450 VA max.

THERMOX O<sub>2</sub> ANALYZER SPECIFICATIONS

Revision 1  
April 2012

# Thermox<sup>®</sup> CEM/O2 Oxygen Analyzer

## User Manual



P/N 90275VE REV. P



---

**Thermox**

150 Freeport Road  
Pittsburgh, PA 15238

# SPECIFICATIONS

## Control Unit

### Display:

4-line x 20-character vacuum fluorescent. Displays combinations of oxygen, time and date, cell temperature, user programmable text, thermocouple mV or cell mV. Password protection, programmable pressure compensation and context-sensitive help are also provided.

### Analog Output:

Two isolated linear current outputs. Select O<sub>2</sub>, cell temperature, thermocouple mV or cell mV. Each output can be 4-20 mA, 0-20 mA, 20-4 mA or 20-0 mA and is fully scalable. Hold or track during calibration and select degree of damping. Maximum load 1200 ohms.

### Alarms:

Two independent oxygen alarms, each high or low selectable. One alarm can be assigned as oxygen, calibrate or verify. Set relays to energize or de-energize on alarm. Contact rating max 30VA, 30V max. non-inductive load.

### Contact Rating:

1A, 30V max. noninductive load, AC or DC

### Diagnostics:

Watchdog timer and service alarms. System test for A/D, RAM, EEPROM and keypad. Display line 4 reserved for full text error and diagnostic messages. Twenty entry event log for automatically detected system events.

### Communications:

RS-485, 2-way addressable

### Environment:

Ambient Temp: 14 – 122°F (-10 – 50°C)

Max. Altitude: 2000 meters

Relative Humidity: 0% to 80%, non-condensing

IEC Installation (Overvoltage) Category: II

IEC Pollution Degree 2

### Enclosure:

Standard GP (General Purpose) 19" rack mount. Optional GP panel or wall mount, weatherproof NEMA 4 (IP56) and NEMA 4X (IP56) enclosures available. All are UL Listed for NEC Class I, Division 2 areas.

**Calibration:**

Store last calibration and verification data. Selectable calibration gas run time and process recovery time. Timed automatic calibration with optional remote calibration unit. Oxygen cell lifetime extender. Single gas verification that analyzer is within calibration limits.

**Power Requirements:**

Nominal 115-230 VAC,  $\pm 10\%$ , 47-63 Hz. max., 75 VA max.

## Sensor

### Operating Range:

0.1 to 100% O<sub>2</sub>

### Accuracy:

± 0.75% of reading or 0.05% O<sub>2</sub>, whichever is greater.

### Response Time:

Less than 4 seconds at 2 scfh from 2% O<sub>2</sub> to 20% O<sub>2</sub>

### Drift:

< 0.1% of cell output per month (< 0.005% O<sub>2</sub> per month with 2% O<sub>2</sub> applied)

### Maximum Inlet Temperature:

400°F (204°C)

### Sample Pressure:

± 2 psig max. (0.14 kg/cm<sup>2</sup>)

### Sample Flow:

2 to 20 scfh (0.94 to 9.4 L/min.)

### Environment:

Ambient Temp: -0 to 122°F (-18 to 50°C)

Relative Humidity: 10% to 90%, non-condensing

Max. Altitude: 2000 meters

IEC Installation (Overvoltage) Category: II

IEC Pollution Degree 2

### Power Requirements:

115 VAC, ±10%, 47-63 Hz.; 230 VAC, ±10%, 47-63 Hz; 1670 VA max.

### Calibration Gas Requirements:

Use calibration gases @ 2 to 20 scfh (0.94 to 9.4 L/min.)

Zero Gas: From 0.1 to 10% O<sub>2</sub>, balance N<sub>2</sub>

Span Gas: Minimum one decade above zero gas (10 times greater)

### System Compliance:

EMC Directive 89/336/EEC

Low Voltage Directive 73-23/EEC

Notes: 1. All static performance characteristics are with operating variables constant. 2. System accuracy reference to 0.1 to 10% calibrated range.



## **Remote Calibration Unit (RCU) O<sub>2</sub> Only RCU**

### **Enclosure:**

UL Type 4X (NEMA 4X [IP56])

### **Environment:**

AmbientTemp.: -18°C to 70°C (32°F to 150°F)

Humidity: 0 to 90%, non-condensing

Max Altitude: 2000 Meters

IEC Installation (Overvoltage) Category: II

IEC Pollution Degree 2

EMC Compliance: 89/336/EEC

Safety Compliance: 73/23/EEC

SIEMENS ULTRAMAT 23 CO ANALYZER  
SPECIFICATIONS

Revision 1  
April 2012

# SIEMENS

## ULTRAMAT 23

Gas Analyzers for IR-absorbing Gases and Oxygen

7MB2335, 7MB2337, 7MB2338

Operating Instructions

02/01



ULTRAMAT 23 gas analyzer, benchtop unit



ULTRAMAT 23 gas analyzer, 19" rack

### 3.5.2 Internal Gas Paths, Gas Flow Diagrams, Basic Layout

#### Basic design

- Gas inlets/outlets:
  - Pipe with 6 mm outside diameter or
  - Pipe with 1/4" outside diameter
- Internal gas paths:
  - Viton tube
- Flowmeter
- Pressure switch

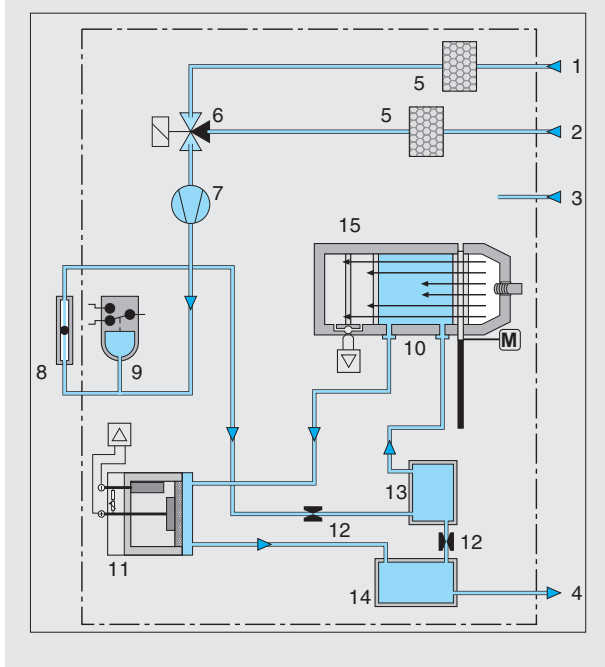

Fig. 3.7 ULTRAMAT 23, 19" unit, e.g. one IR component with oxygen measurement, with internal sample gas pump and safety filter

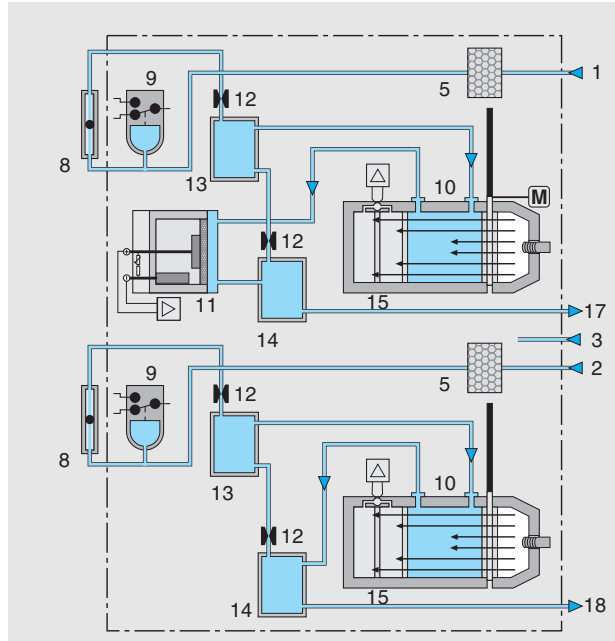

Fig. 3.8 ULTRAMAT 23, 19" unit, two channels with separate gas paths, e.g. two IR components with oxygen measurement, without sample gas pump, with internal safety filter

#### Key to Figures 7 to 11

- |   |   |
|---|---|
| <ul style="list-style-type: none"> <li>1 Inlet for sample gas / calibration gas</li> <li>2 Inlet for AUTOCAL / zero gas or inlet for sample gas / calibration gas (channel 2)</li> <li>3 Enclosure purge inlet / chopper purge</li> <li>4 Gas outlet</li> <li>5 Membrane safety filter</li> <li>6 Solenoid valve <sup>1)</sup></li> <li>7 Sample gas pump <sup>1)</sup></li> <li>8 Flowmeter</li> </ul> | <ul style="list-style-type: none"> <li>9 Pressure switch</li> <li>10 Sample cell (see Fig. 3.3)</li> <li>11 Oxygen measuring cell<sup>1)</sup> (see Fig. 3.4)</li> <li>12 Restrictor</li> <li>13 Condensation trap</li> <li>14 Condensation trap</li> <li>15 Infrared measuring cell</li> <li>16 Condensation trap with filter</li> <li>17 Gas outlet</li> <li>18 Gas outlet (channel 2)</li> </ul> |
|---|---|

<sup>1)</sup> Depending on design, see Ordering data, pages 17 to 22

## 3.1 Application

The **ULTRAMAT 23** gas analyzer can measure up to 4 gas components at once: A maximum of three infrared sensitive gases such as CO, CO<sub>2</sub>, NO, SO<sub>2</sub>, CH<sub>4</sub>, R22 (Freon CHClF<sub>2</sub>) plus O<sub>2</sub> with an electrochemical oxygen measuring cell.

**ULTRAMAT 23** basic versions for:

- 1 infrared gas component with/without oxygen measurement
- 2 infrared gas components with/without oxygen measurement
- 3 infrared gas components with/without oxygen measurement

Specific applications:

The **ULTRAMAT 23** with 2 IR components without pump and with or without oxygen measurement is also available with two separate gas paths. This allows the measurement of two measuring points as used e.g. for the NO<sub>x</sub> measurement before and after the NO<sub>x</sub> converter.

The **ULTRAMAT 23** gas analyzer can be used in emission measuring systems and for process and safety monitoring.

TÜV-approved versions of the **ULTRAMAT 23** are available for measurement of CO, NO, SO<sub>2</sub> and O<sub>2</sub> according to 13. BImSchV and TA Luft.

Smallest TÜV-approved and permitted measuring ranges:

- 1- and 2-component analyzer
  - CO: 0 to 150 mg/m<sup>3</sup>
  - NO: 0 to 250 mg/m<sup>3</sup>
  - SO<sub>2</sub>: 0 to 400 mg/m<sup>3</sup>
- 3-Komponenten-Analysator
  - CO: 0 to 250 mg/m<sup>3</sup>
  - NO: 0 to 400 mg/m<sup>3</sup>
  - SO<sub>2</sub>: 0 to 400 mg/m<sup>3</sup>

All larger measuring ranges are also permitted.

For use in non-potentially explosive atmospheres.

### Application examples

- Optimization of small firing systems
- Monitoring of exhaust gas concentration from firing systems with all types of fuel (oil, gas and coal) as well as operational measurements with thermal incineration plants
- Room air monitoring
- Monitoring of air in fruit stores, greenhouses, fermenting cellars and warehouses
- Monitoring of process control functions
- Atmosphere monitoring during heat treatment of steel.

### Special characteristics

- Stable 19" sheet-steel enclosure for mounting in hinged bay or on slide rails.  
Option: bench-top version with handles as well as condensation trap and coarse filter
- Operation based on NAMUR recommendation
- Simple, fast programming and commissioning of analyzer
- Practically maintenance-free as a result of AUTOCAL with ambient air (or with N<sub>2</sub> for analyzers without oxygen sensor); both the zero and the span are calibrated in the process
- Calibration with calibration gas is only necessary every six to 12 months, depending on application
- Large, backlit LCD for measured values; menu-based inputs for programming, test functions and calibration
- Two measuring ranges can be set per component within defined limits;  
all measuring ranges linearized;  
autoranging with range identification
- Automatic correction of variations in atmospheric pressure
- Gas flow monitoring;  
Low-flow alarm at < 1 l/min
- Maintenance request alert
- Two limits can be freely configured for each component, for upward or downward violation
- Three binary inputs for sample gas pump on/off, triggering of AUTOCAL and synchronization of several devices
- Eight relay outputs can be freely configured for fault, maintenance request, maintenance switch, limits, range identification, external solenoid valves
- Four electrically isolated analog outputs;  
RS 485 present in basic device;  
option: converter to RS 232
- Incorporation in networks via PROFIBUS-DP/-PA interface
- SIPROM GA software as service and maintenance tool
- Eight additional relay outputs as an option
- Eight additional binary outputs as an option.

TECO MODEL 48C CO ANALYZER SPECIFICATIONS

Revision 1  
April 2012

# **MODEL 48C**

## **GAS FILTER CORRELATION CO ANALYZER**

**INSTRUCTION MANUAL  
P/N 42P255**



**THERMO ELECTRON CORPORATION  
ENVIRONMENTAL INSTRUMENTS  
27 FORGE PARKWAY FRANKLIN MASSACHUSETTS 02038**

**(866) 282-0430 Toll Free  
(508) 520-0430 International  
(508) 520-1460 Fax**

**[www.thermo.com/eid](http://www.thermo.com/eid)**

3Mar2004

*The 220V option complies with 89/336/EEC directive for electromagnetic compatibility.*

## Chapter 1 Introduction

The CO gas filter acts to produce a reference beam which cannot be further attenuated by CO in the sample cell. The N<sub>2</sub> side of the filter wheel is transparent to the infrared radiation and therefore produces a measure beam which can be absorbed by CO in the cell. The chopped detector signal is modulated by the alternation between the two gas filters with an amplitude related to the concentration of CO in the sample cell. Other gases do not cause modulation of the detector signal since they absorb the reference and measure beams equally. Thus the GFC system responds specifically to CO.

The Model 48C outputs the CO concentration to the front panel display and the analog outputs.

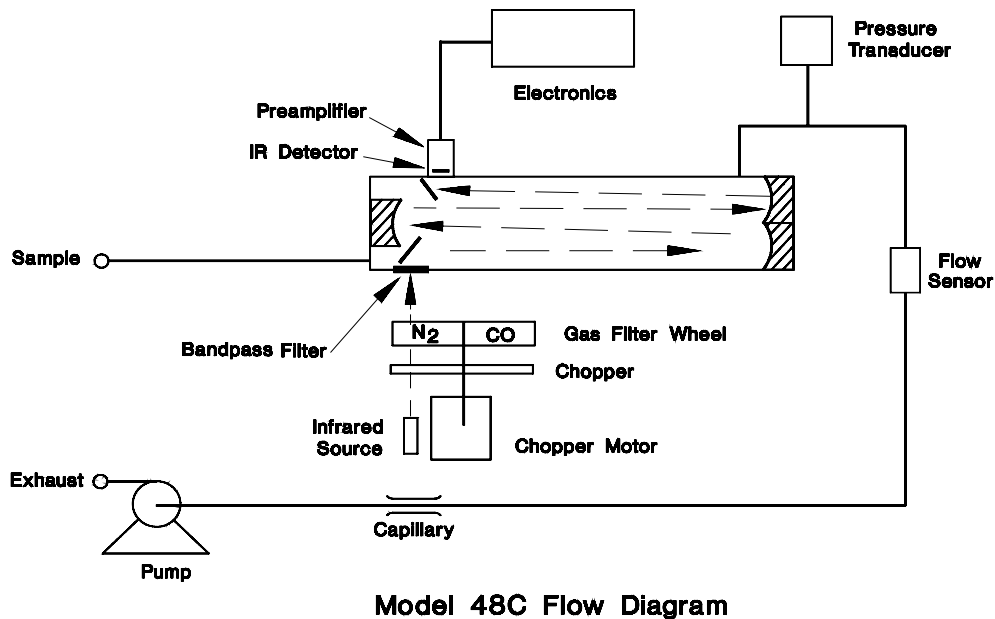

Figure 1-1. Model 48C Flow Schematic

B42P809



**SPECIFICATIONS**

Preset ranges	0-1, 2, 5, 10, 20, 50, 100, 200, 500, 1000, 2000, 5000, 10000 ppm 0-1, 2, 5, 10, 20, 50, 100, 200, 500, 1000, 2000, 5000, 10000 mg/m <sup>3</sup>
Custom ranges	0-1 to 10000 ppm 0-1 to 10000 mg/m <sup>3</sup>
Zero noise	0.02 ppm RMS (30 second time setting)
Lower detectable limit	0.04 ppm
Zero drift (24 hour)	< 0.1 ppm
Span drift (24 hour)	±1% fullscale
Response time	60 seconds (30 second time setting)
Precision	± 0.1 ppm
Linearity	± 1% fullscale ≤ 1000 ppm ± 2.5% fullscale > 1000 ppm
Sample flow rate	0.5-2 liters/min
Operating temperature	20 - 30°C (may be safely operated over the range of 0 - 45°C)*
Power requirements	105-125 VAC, 60 Hz 220-240 VAC, 50 Hz 100 Watts
Physical dimensions	16.75" (W) X 8.62" (H) X 23" (D)
Weight	45 lbs.
Outputs	CO selectable voltage 4-20 mA, RS-232, RS-485

\* In non-condensing environments